

CATALOGO

2025

SINIS

IT +39 022 1117815
IT +39 335 7600875
EN/FR +39 3425447140
ES +34 664 66 64 26
ES +34 664 66 64 28

Info@sineditalia.com

SINEDITALIA.COM
SINEDITALIA.IT
SINED.ES

DOCCE IN ACCIAIO INOX 316L NAUTICO

316L NAUTICAL STAINLESS STEEL SHOWERS

Le Docce Sined in Acciaio Inox 316L presentano un elegante Design innovativo e moderno e sono studiate anche per utilizzo in ambiente marino.

Sono Docce con speciale collegamento a terra tramite sistema di fissaggio speciale brevettato C-BOX con collegamenti per acqua calda e fredda.

Le docce Sined Inox sono prodotte in due parti facilmente assemblabili per una movimentazione più rapida in una robusta confezione lunga solo 120 cm.

Ricambi e parti di ricambio sono pronti per essere spediti entro 24/48h dai magazzini in Italia. Sono facilmente rimovibili dal C-BOX e possono essere smontate e conservate al coperto in inverno. La Sacca protettiva è inclusa nella confezione.

Sined Stainless Steel 316L Showers feature an elegant innovative and modern Design and are also designed for use in marine environment.

They are Showers with special ground connection by special patented C-BOX fixing system with hot and cold water connections. Sined Inox showers are produced in two parts that can be easily assembled for faster handling in a sturdy package only 120 cm long.

Spare and replacement parts are ready to be shipped within 24/48 from warehouses in Italy. They are easily removable from the C-BOX and can be disassembled and stored indoors in winter. A protective bag is included in the package.



SISTEMA DI FISSAGGIO RAPIDO A PAVIMENTO PER LE DOCCE INOX

CHE COS'È?

Nella confezione delle docce in acciaio Sined è compreso tutto il necessario per la loro installazione. L'esclusivo sistema C-BOX ti permetterà di assicurare la tua doccia collegandola direttamente all'impianto di casa, acqua calda e fredda. Tutto in modo facile e sicuro.

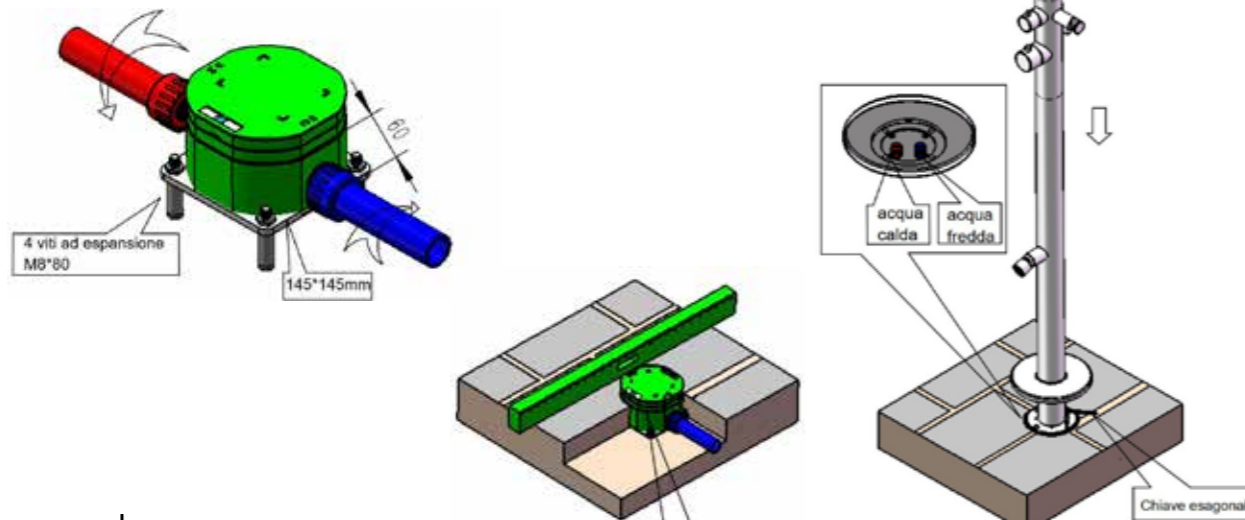

Il C-Box consente una installazione perfetta, ed è protetto con un coperchio richiudibile per quando la doccia viene smontata. Il C-BOX deve essere installato perfettamente in bolla e fissato al suolo nel cemento con i 4 tasselli metallici in dotazione. All'interno del C-BOX troviamo gli innesti ad attacco rapido per collegare la doccia in acciaio. Gli attacchi rapidi posizionati alla base della doccia sono connessi con un triplo sistema di anelli OR a tenuta stagna. Anche tutti gli attrezzi in dotazione sono in acciaio.

WHAT IS IT?

Included in the package of Sined steel showers is everything you need for their installation. The exclusive C-BOX system will allow you to secure your shower by

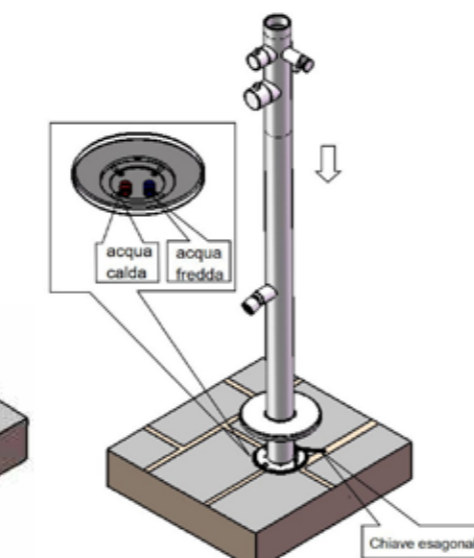

The C-Box allows perfect installation, and is protected with a lockable cover for when the shower is disassembled. The C-BOX must be installed perfectly level and fixed to the ground in concrete with the 4 metal plugs provided. Inside the C-BOX we find the quick-connect couplings to connect the steel shower. The couplings quick couplings located at the base of the shower are connected with a triple system of watertight OR rings. All of the supplied tools are also made of steel.

QUICK FLOOR ATTACHMENT SYSTEM FOR STAINLESS STEEL SHOWERS

Sined Stainless Steel 316L Showers feature an elegant innovative and modern Design and are a/so designed for use in marine environment. They are Showers with special ground connection by special patented C-BOX fixing system with hot and cold water connections. Sined Inox showers are produced in two parts that can be easily assembled for faster handling in a sturdy package only 120 cm long. Spare and replacement parts are ready to be shipped within 24/48 from warehouses in Italy. They are easily removable from the C-BOX and can be disassembled and stored indoors in winter. A protective bag is included in the package.

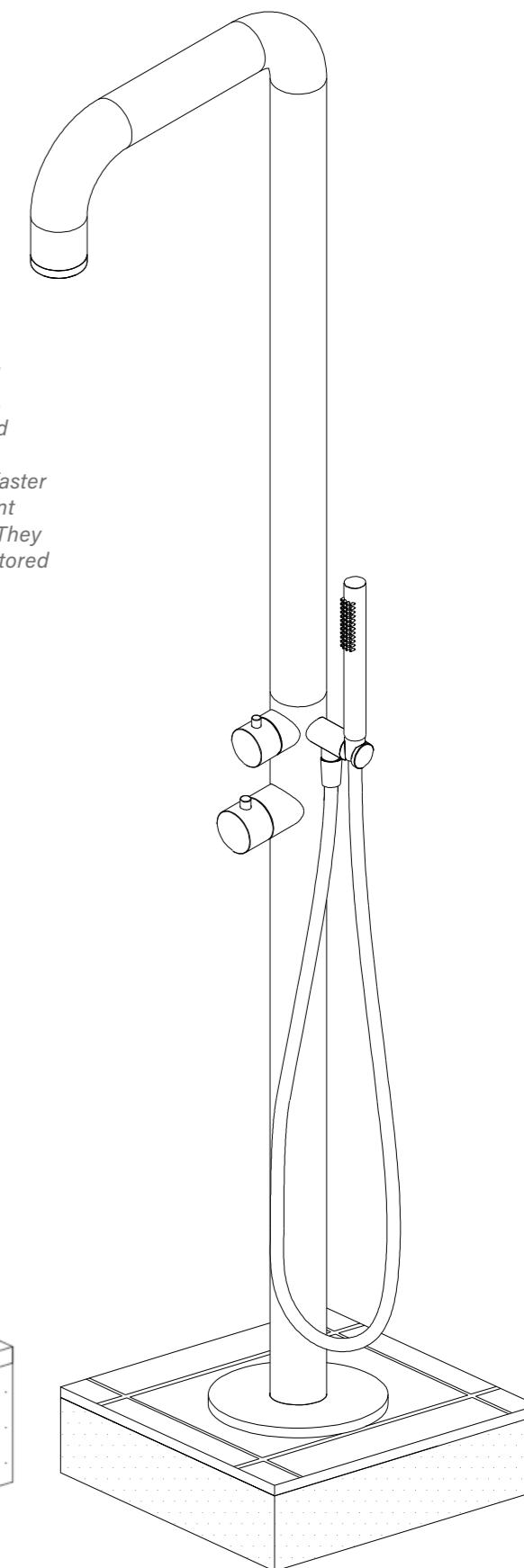
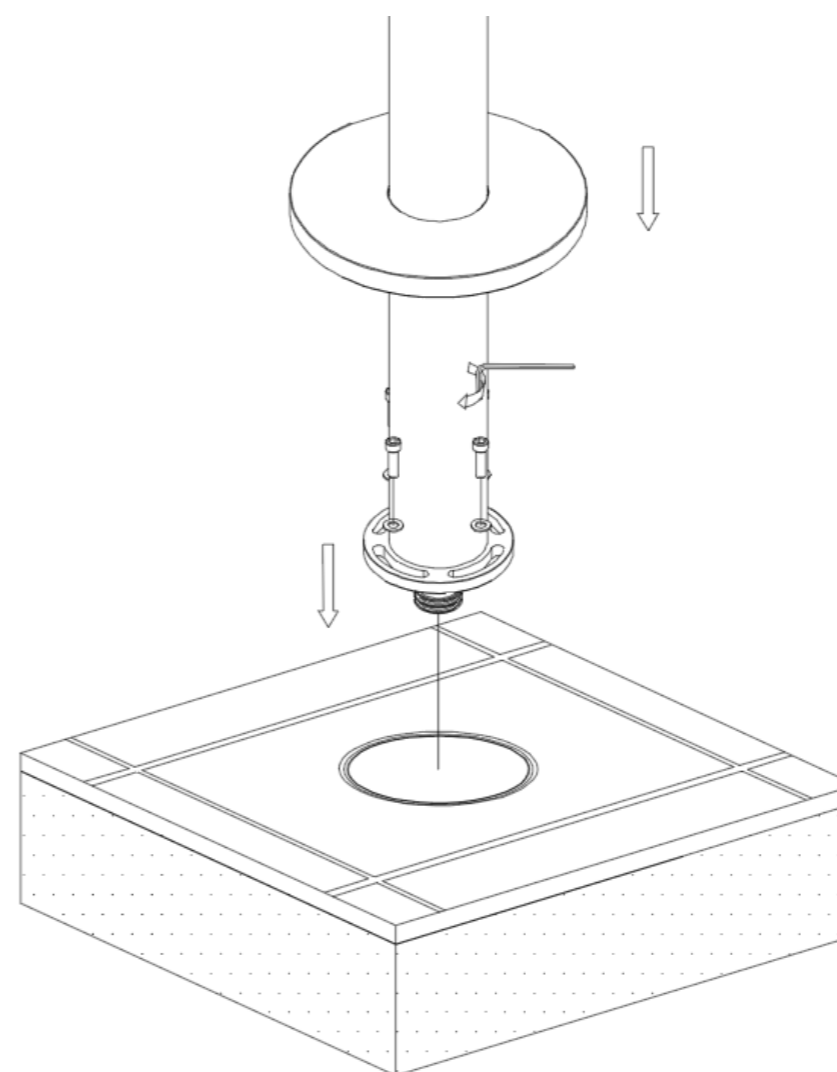

**IT**

Doccia Da Esterno Chia Sined In Acciaio Inox Satinato Doccia Con Miscelatore e Doccia a Mano Struttura Ed Accessori In Acciaio Inox Aisi 316l Fusto Diametro 6 Cm Doccia Con Ingresso Acqua Calda e Fredda Attacchi a Scomparsa Nella Base h 2300 Mm.

EN

Outdoor Shower Chia Sined In Satin Stainless Steel Shower With Mixer And Hand Shower Structure And Accessories In Stainless Steel Aisi 316l Drum Diameter 6 Cm Shower With Hot And Cold Water Inlet Concealed Connections In The Base h 2300 Mm.

FR

Douche D'extérieur Chia Sined En Acier Inox Satiné Douche Avec Mitigeur Et Douchette à Main Structure Et Accessoires En Acier Inox Aisi 316l Diamètre Du Tambour 6 Cm Douche Avec Arrivée D'eau Chaude Et Froide Raccordements Cachés Dans La Base h 2300 Mm.

DE

Außendusche Chia Sined Aus Satiniertem Edelstahl Dusche Mit Mischbatterie Und Handbrause Struktur Und Zubehör Aus Edelstahl Aisi 316l Trommeldurchmesser 6 Cm Dusche Mit Warm- Und Kaltwasseranschluss Verdeckte Anschlüsse Im Boden h 2300 Mm.

ES

Ducha Exterior Chia Sined En Acero Inoxidable Satinado Ducha Con Mezclador y Teleducha Estructura y Accesorios En Acero Inoxidable Aisi 316l Diámetro Del Tambor 6 Cm Ducha Con Entrada De Agua Caliente y Fría Conexiones Ocultas En La Base h 2300 Mm.

**DOCCIA-CHIA-INOX**

8025431016712

MATERIALE ACCIAIO INOX 316L
MATERIAL 316L STAINLESS

UGELLI ANTICALCARE
ANTISCALE NOZZLES

PESO 9,5 KG
WEIGHT 9,5 KG

INCLUDE UNA SACCA
DI PROTEZIONE
INCLUDES A
PROTECTION BAG



GETTO D'ACQUA
VERTICALE
WATER JET
VERTICAL



ACCESSORI ACCIAIO INOX 304
ACCESSORIES STAINLESS STEEL 304

PRODOTTO IN DUE
PARTI. SCATOLA FACILE DA
MANEGGIARE
PRODUCT IN TWO
PARTS EASY-TO-HANDLE
BOX



ACQUA
CALDA E FREDDA
WATER
HOT AND COLD

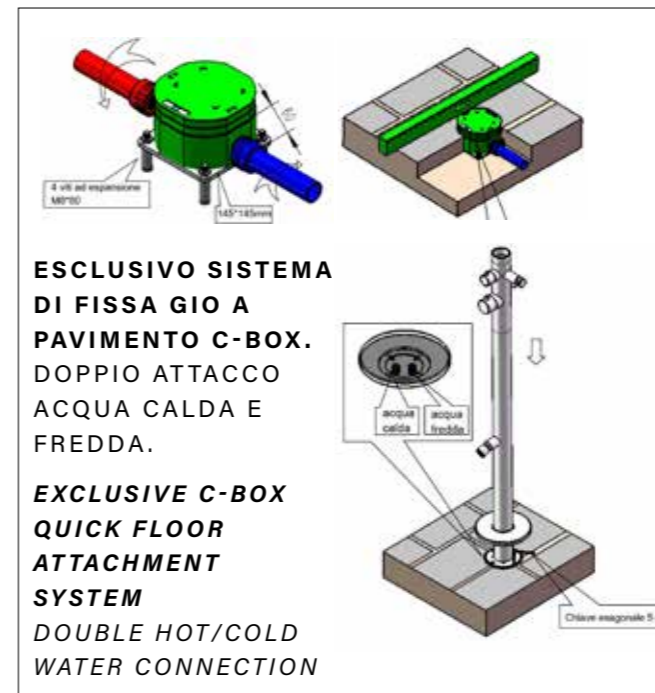

ESCLUSIVO SISTEMA
DI FISSA GIO A
PAVIMENTO C-BOX.
DOPPIO ATTACCO
ACQUA CALDA E
FREDDA.

EXCLUSIVE C-BOX
QUICK FLOOR
ATTACHMENT
SYSTEM
DOUBLE HOT/COLD
WATER CONNECTION

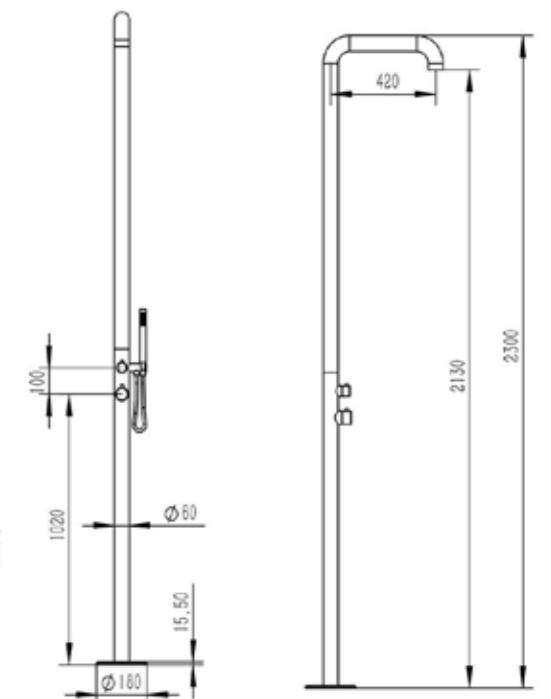

DOCCIA-CHIA-NERA

8025431016729

MATERIALE ACCIAIO INOX 316L
MATERIAL 316L STAINLESS

UGELLI ANTICALCARE
ANTISCALE NOZZLES

PESO 9,5 KG
WEIGHT 9,5 KG

INCLUDE UNA SACCA
DI PROTEZIONE
INCLUDES A
PROTECTION BAG



GETTO D'ACQUA
VERTICALE
WATER JET
VERTICAL



ACCESSORI ACCIAIO INOX 304
ACCESSORIES STAINLESS STEEL 304

PRODOTTO IN DUE
PARTI. SCATOLA FACILE DA



MANEGGIARE
PRODUCT IN TWO
PARTS EASY-TO-HANDLE
BOX

ACQUA
CALDA E FREDDA
WATER
HOT AND COLD



IT

Doccia Inox Sined
Per Piscina Chia Nera
Black Matte Doccia Con
Miscelatore e Doccetta
Corpo e Accessori In
Acciaio Nautico Inox Aisi
316l Nero Opaco Fusto
Diametro 6 Cm Doccia Per
Interno Ed Esterno Con
Ingresso Acqua Calda e
Fredda Dal Basso h 2300

EN

Sined Shower For
Swimming Pool Chia Nera
Shower With Mixer And
Handshower Body And
Accessories In Stainless
Steel Aisi 316l Matt Black
Body Diameter 6 Cm
Shower For Indoor And
Outdoor Use With Hot
And Cold Water Inlet From
Below h 2300 Mm.

FR

Douche Pour Piscine Chia
Nera Douche Avec Mitigeur
Et Douchette Corps Et
Accessoires En Acier Inox
Aisi 316l Noir Mat Diamètre
Du Corps 6 Cm Douche
Pour Intérieur Et Extérieur
Avec Arrivée D'eau Chaude
Et Froide Par Le Bas h 2300
Mm.

DE

Sined Dusche Für
Schwimmbad Chia Nera
Dusche Mit Mischer Und
Handbrause Körper Und
Zubehör Aus Edelstahl
Aisi 316l Mattschwarz
Körperdurchmesser 6 Cm
Dusche Für Den Innen- Und
Außenbereich Mit Warm-
Und Kaltwasserzulauf Von
Unten h 2300 Mm.

ES

Ducha Sined Para Piscina
Chia Nera Ducha Con
Mezclador y Teleducha
Cuerpo y Accesorios En
Acero Inoxidable Aisi 316l
Negro Mate Diámetro Del
Cuerpo 6 Cm Ducha Para
Uso Interior y Exterior Con
Entrada De Agua Caliente
y Fría Por Abajo h 2300
Mm.

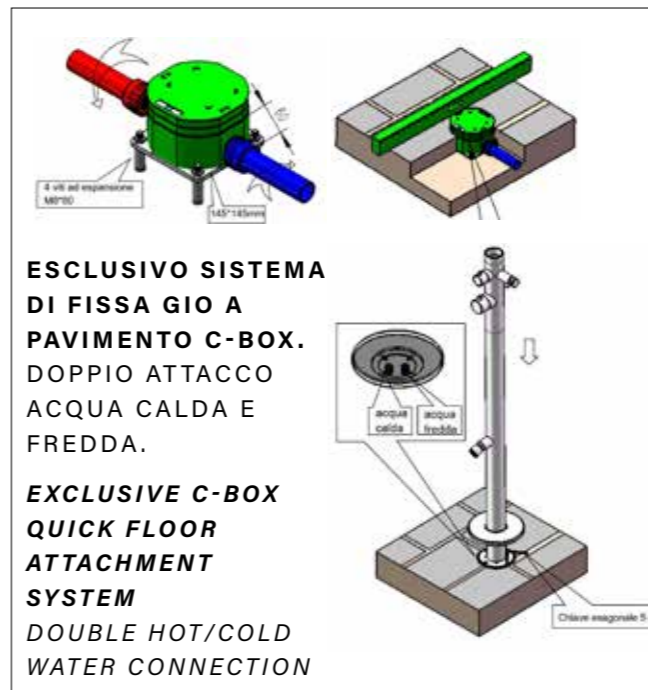
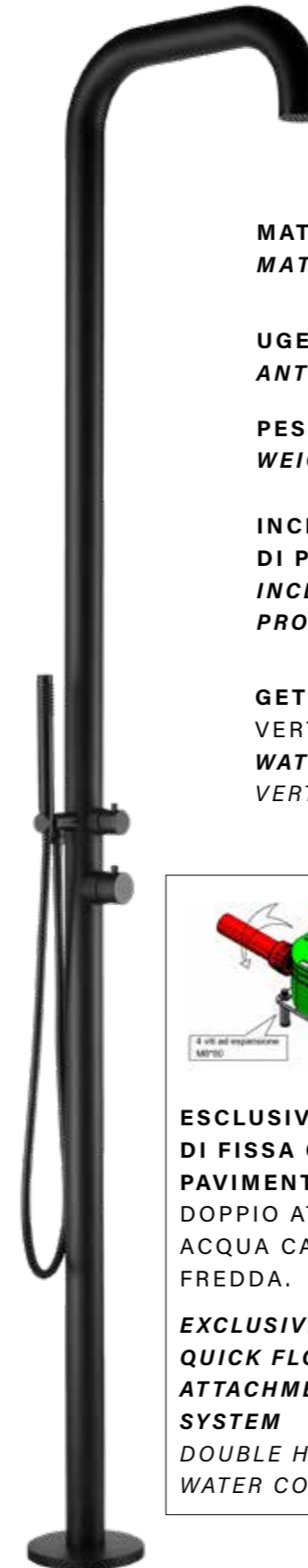
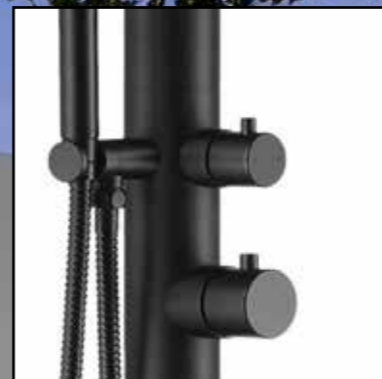

ESCLUSIVO SISTEMA
DI FISSA GIO A
PAVIMENTO C-BOX.
DOPPIO ATTACCO
ACQUA CALDA E
FREDDA.

EXCLUSIVE C-BOX
QUICK FLOOR
ATTACHMENT
SYSTEM
DOUBLE HOT/COLD
WATER CONNECTION

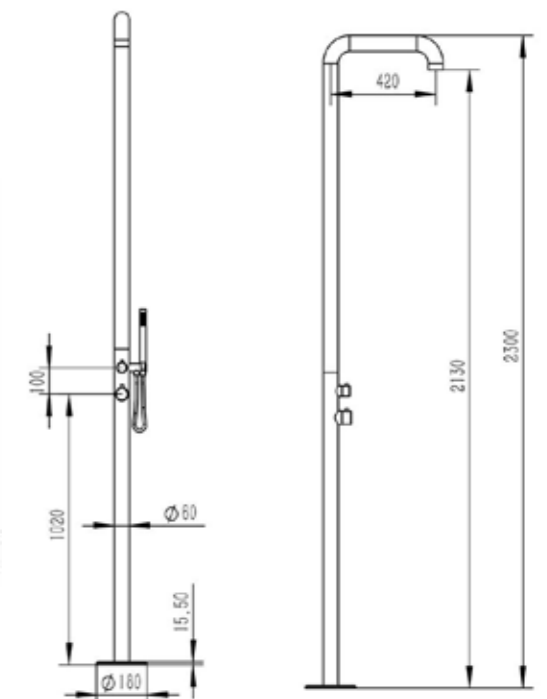

DOCCIA-CHIA-BIANCA

8025431153059

MATERIALE ACCIAIO INOX 316L
MATERIAL 316L STAINLESS

UGELLI ANTICALCARE
ANTISCALE NOZZLES

PESO 9,5 KG
WEIGHT 9,5 KG

INCLUDE UNA SACCA
DI PROTEZIONE
INCLUDES A
PROTECTION BAG



GETTO D'ACQUA
VERTICALE
WATER JET
VERTICAL



ACCESSORI ACCIAIO INOX 304
ACCESSORIES STAINLESS STEEL 304

DUE FILTRI ANTICALCARE INCLUSI
TWO ANTI-SCALE FILTERS INCLUDED

FILTRO ANTICALCARE INCLUSO
FILTER LIMESCALE INCLUDED



PRODOTTO IN DUE
PARTI. SCATOLA FACILE DA
MANEGGIARE
PRODUCT IN TWO-
PARTS EASY-TO-HAN-
DLE BOX

ACQUA
CALDA E FREDDA
WATER
HOT AND COLD



IT

Doccia Esterna Bianca
Chia Sined In Acciaio Inox
: Miscelatore e Doccino,
Struttura e Accessori In
Aisi 316l, Fusto Diametro 6
Cm, Acqua Calda/fredda,
Attacchi Integrati, Altezza
2300 Mm. Ideale Per
Esterno e Interno, Anche
Per Ambienti Marini.

EN

White Chia Sined Stainless
Steel Outdoor Shower
: Mixer And Shower,
Structure And Accessories
In Aisi 316l, 6 Cm Diameter
Drum, Hot/cold Water,
Integrated Connections,
Height 2300 Mm. Ideal For
Outdoor And Indoor, Also
For Marine Environments.

FR

Douche d'extérieur en
acier inoxydable Chia
Sined : mitigeur et douche,
cadre et accessoires en
Aisi 316l, axe de 6 cm de
diamètre, eau chaude/
froide, raccords
intégrés, hauteur 2300 mm.
Idéal pour l'extérieur et
l'intérieur, également pour
les environnements marins.

DE

Chia Sined Edelstahl-
Außendusche:
Mischbatterie und Dusche,
Rahmen und Zubehör aus
Aisi 316l, Welle mit 6 cm
Durchmesser, Warm-/
Kaltwasser, integrierte
Anschlüsse, Höhe 2300
mm. Ideal für den Außen-
und Innenbereich, auch für
Meeresumgebungen.

ES

Ducha de Exterior Chia
Sined Acero Inoxidable:
Mezclador y Ducha, Marco
y Accesorios en Aisi 316l,
Eje de 6 cm de diámetro,
Agua Caliente/Fría,
Conexiones Integradas,
Altura 2300 mm. Ideal para
exteriores e interiores,
también para ambientes
marinos.

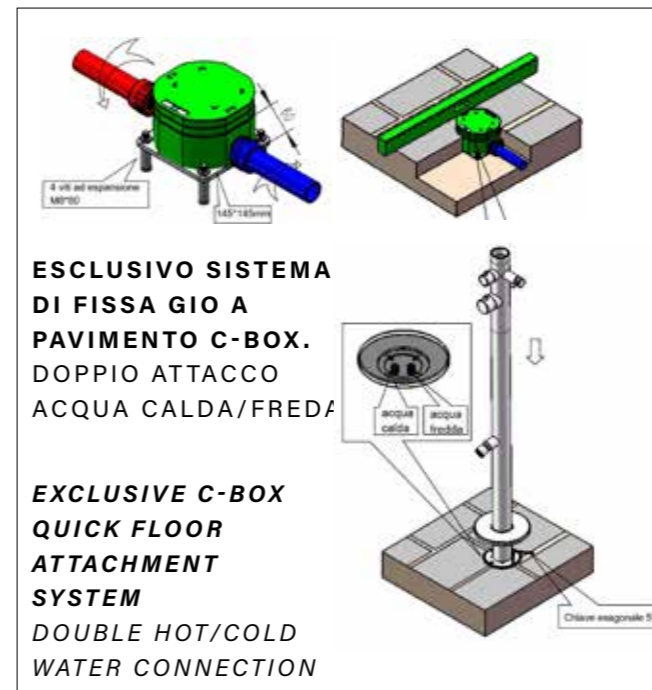

ESCLUSIVO SISTEMA
DI FISSA GIO A
PAVIMENTO C-BOX.
DOPPIO ATTACCO
ACQUA CALDA/FREDDA

EXCLUSIVE C-BOX
QUICK FLOOR
ATTACHMENT
SYSTEM
DOUBLE HOT/COLD
WATER CONNECTION

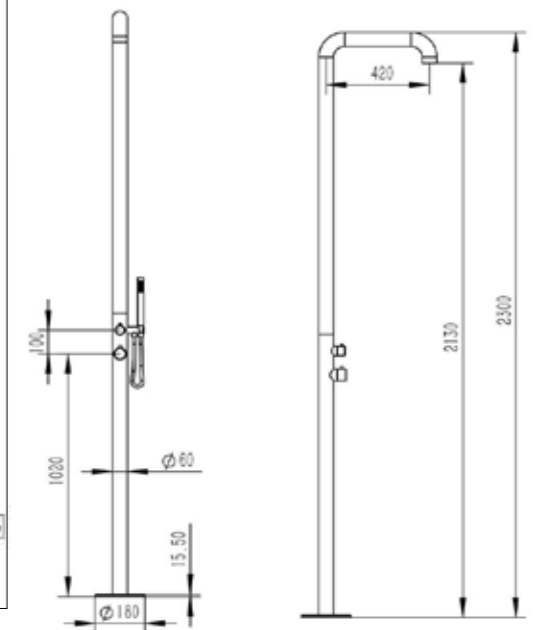

**IT**

Doccia In Acciaio Inox Nautico 316l Sined Chia Canna Fucile Miscelatore e Doccino, Struttura e Accessori In Aisi 316l, Fusto Diametro 6 Cm, Acqua Calda/fredda, Attacchi Integrati, Altezza 2300 Mm. Ideale Per Esterno e Interno, Anche Per Ambienti Marini.

EN

Sined Chia Canna Fucile Mixer and Shower, Frame and Accessories in Aisi 316l, Drum Diameter 6 cm, Hot/Cold Water, Integrated Connections, Height 2300 mm. Ideal for outdoors and indoors, also for marine environments.

FR

Mélangeur et douche Sined Chia Canna Fucile, cadre et accessoires en Aisi 316l, diamètre du tambour 6 cm, eau chaude/eau froide, raccords intégrés, hauteur 2300 mm. Idéal pour l'extérieur et l'intérieur, également pour les environnements marins.

DE

Sined Chia Canna Fucile Mischbatterie und Dusche, Rahmen und Zubehör aus Aisi 316l, Trommeldurchmesser 6 cm, Warm-/Kaltwasser, integrierte Anschlüsse, Höhe 2300 mm. Ideal für den Außen- und Innenbereich, auch für Meeresumgebungen.

ES

Mezclador y Ducha Sined Chia Canna Fucile, Marco y Accesorios en Aisi 316l, Diámetro del Tambor 6 cm, Agua Caliente/Frío, Conexiones Integradas, Altura 2300 mm. Ideal para exteriores e interiores, también para ambientes marinos.

DOCCIA-CHIA-CANNA-FUCILE

8025431153066

MATERIALE ACCIAIO INOX 316L
MATERIAL 316L STAINLESS

UGELLI ANTICALCARE
ANTISCALE NOZZLES

PESO 9,5 KG
WEIGHT 9,5 KG

INCLUDE UNA SACCA
DI PROTEZIONE
INCLUDES A
PROTECTION BAG



GETTO D'ACQUA
VERTICALE
WATER JET
VERTICAL



ACCESSORI ACCIAIO INOX 304
ACCESSORIES STAINLESS STEEL 304

SPECIALE TRATTAMENTO
VERNICIATURA PVD
SPECIAL PVD VARNISHING
TREATMENT

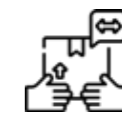

PRODOTTO IN DUE
PARTI. SCATOLA
FACILE DA MANEGGIARE
PRODUCT IN TWO PARTS
EASY-TO-HANDLE BOX

ACQUA
CALDA E FREDDA
WATER
HOT AND COLD

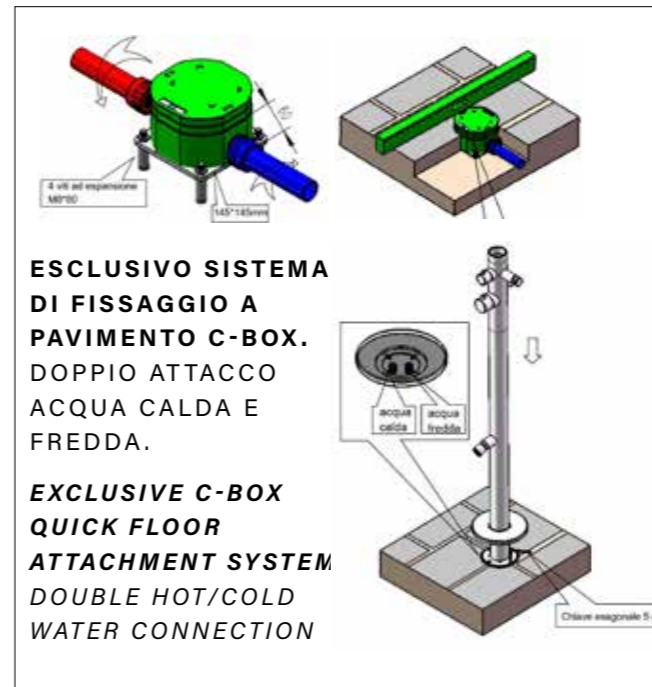

ESCLUSIVO SISTEMA
DI FISSAGGIO A
PAVIMENTO C-BOX.
DOPPIO ATTACCO
ACQUA CALDA E
FREDDA.

EXCLUSIVE C-BOX
QUICK FLOOR
ATTACHMENT SYSTEM
DOUBLE HOT/COLD
WATER CONNECTION

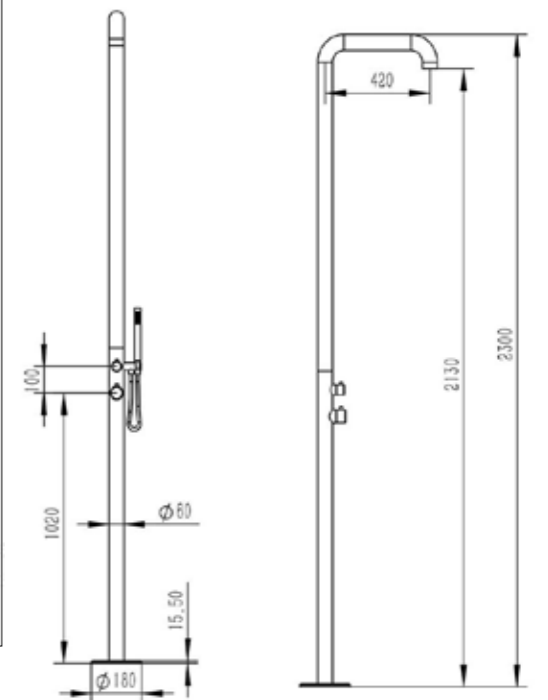

DOCCIA-CHIA-ORO

8025431153042

MATERIALE ACCIAIO INOX 316L
MATERIAL 316L STAINLESS

UGELLI ANTICALCARE
ANTISCALE NOZZLES

PESO 9,5 KG
WEIGHT 9,5 KG

INCLUDE UNA SACCA
DI PROTEZIONE
INCLUDES A
PROTECTION BAG



GETTO D'ACQUA
VERTICALE
WATER JET
VERTICAL



ACCESSORI ACCIAIO INOX 304
ACCESSORIES STAINLESS STEEL 304

SPECIALE TRATTAMENTO
VERNICIATURA PVD
SPECIAL PVD VARNISHING
TREATMENT

PRODOTTO IN DUE
PARTI. SCATOLA
FACILE DA MANEGGIARE
PRODUCT IN TWO PARTS
EASY-TO-HANDLE BOX



ACQUA
CALDA E FREDDA
WATER
HOT AND COLD

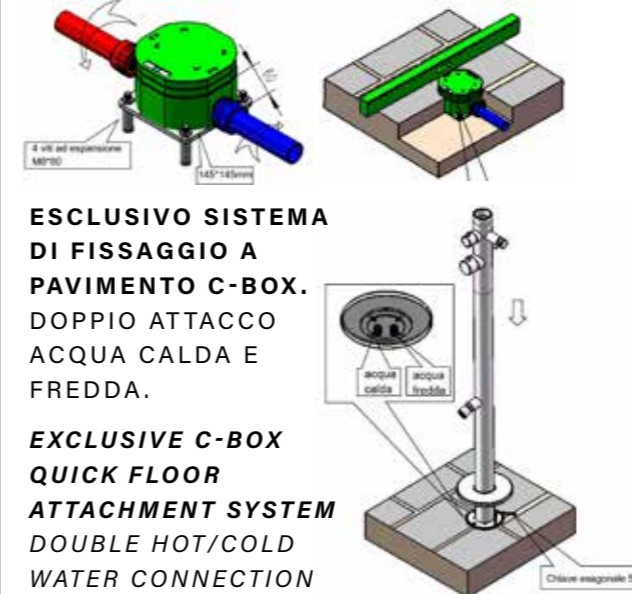

ESCLUSIVO SISTEMA
DI FISSAGGIO A
PAVIMENTO C-BOX.
DOPPIO ATTACCO
ACQUA CALDA E
FREDDA.

EXCLUSIVE C-BOX
QUICK FLOOR
ATTACHMENT SYSTEM
DOUBLE HOT/COLD
WATER CONNECTION

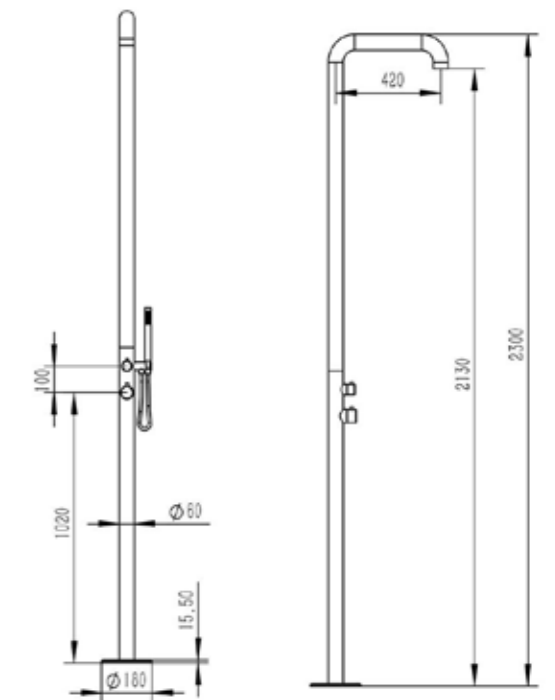

IT

Doccia in Acciaio Inox Nautico 316L Sined CHIA ORO. Miscelatore e Doccino, Struttura e Accessori in AISI 316L, Fusto diametro 6 cm, acqua Calda/Fredda, Attacchi Integrati, altezza 2300 mm. Ideale per esterno e interno, anche per ambienti marini e termali.

EN

Sined CHIA ORO 316L Stainless Steel Shower. Mixer and Shower, Structure and Accessories in AISI 316L, Drum diameter 6 cm, Hot/Cold water, Integrated connections, height 2300 mm. Ideal for outdoors and indoors, also for marine and spa environments.

FR

Douche Sined CHIA ORO en acier inoxydable 316L. Mélangeur et douche, structure et accessoires en AISI 316L, diamètre du tambour 6 cm, eau chaude/froide, raccords intégrés, hauteur 2300 mm. Idéal pour l'extérieur et l'intérieur, également pour les environnements marins et spa.

DE

Sined CHIA ORO 316L Dusche aus Edelstahl. Mischbatterie und Dusche, Struktur und Zubehör aus AISI 316L, Trommeldurchmesser 6 cm, Warm-/Kaltwasser, integrierte Anschlüsse, Höhe 2300 mm. Ideal für den Außen- und Innenbereich, auch für Bäder.

ES

Sined CHIA ORO Ducha en Acero Inoxidable 316L. Mezclador y Ducha, Estructura y Accesorios en AISI 316L, Diámetro del tambor 6 cm, Agua caliente/fría, Conexiones integradas, Altura 2300 mm. Ideal para exteriores e interiores, también para ambientes marinos y balnearios.



IT

Doccia In Acciaio Inox Nautico 316l Sined Chia Oro Rosa. Miscelatore e Doccino, Acciaio Inox Aisi 316l, Fusto Diametro 6 Cm, Acqua Calda/fredda, Attacchi Integrati, Altezza 2300 Mm. Ideale Per Esterno e Interno, Anche Per Ambienti Marini e Termali.

EN

Sined Chia Chia Rose Gold Stainless Steel Shower. Mixer and Hand Shower, Stainless Steel Aisi 316l, Drum Diameter 6 cm, Hot/ Cold Water, Integrated Connections, Height 2300 mm. Ideal for outdoors and indoors, also for marine and spa environments.

FR

Sined Chia Chia Rose Gold Douche en acier inoxydable. Mélangeur et douchette, acier inoxydable Aisi 316l, diamètre du tambour 6 cm, eau chaude/froide, connexions intégrées, hauteur 2300 mm. Idéale pour l'extérieur et l'intérieur, ainsi que pour les environnements marins et les spas.

DE

Sined Chia Chia Rose Gold Dusche aus Edelstahl. Mischbatterie und Handbrause, Edelstahl Aisi 316l, Trommeldurchmesser 6 cm, Warm-/Kaltwasser, integrierte Anschlüsse, Höhe 2300 mm. Ideal für den Außen- und Innenbereich, auch für Marine- und Spa-les spas.

ES

Sined Chia Ducha de Acero Inoxidable Oro Rosa. Mezclador y Teleducha, Acero Inoxidable Aisi 316l, Diámetro del Tambor 6 cm, Agua Caliente/Fría, Conexiones Integradas, Altura 2300 mm. Ideal para exteriores e interiores, también para ambientes marinos y balnearios.

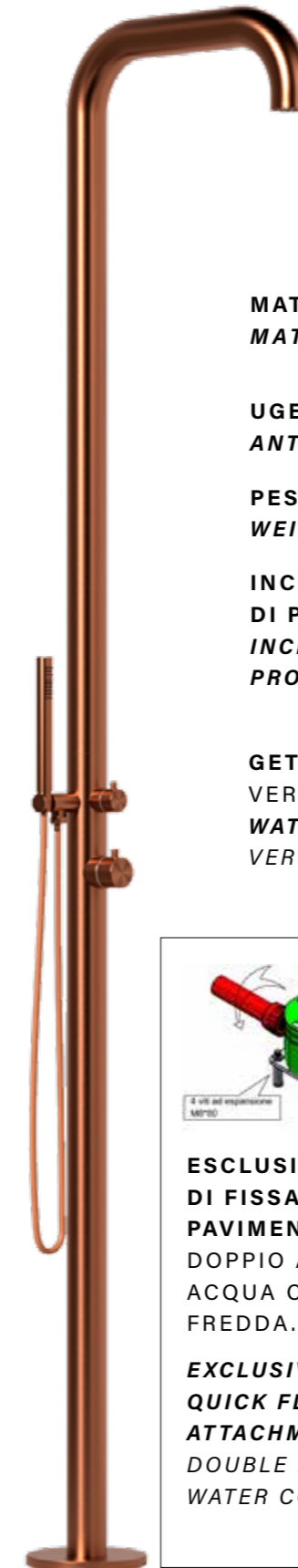

DOCCIA-CHIA-ORO-ROSA

8025431153073

MATERIALE ACCIAIO INOX 316L
MATERIAL 316L STAINLESS

UGELLI ANTICALCARE
ANTISCALE NOZZLES

PESO 9,5 KG
WEIGHT 9,5 KG

INCLUDE UNA SACCA
DI PROTEZIONE
INCLUDES A
PROTECTION BAG



GETTO D'ACQUA
VERTICALE
WATER JET
VERTICAL



ACCESSORI ACCIAIO INOX 304
ACCESSORIES STAINLESS STEEL 304

SPECIALE TRATTAMENTO
VERNICIATURA PVD
SPECIAL PVD VARNISHING
TREATMENT



PRODOTTO IN DUE
PARTI. SCATOLA
FACILE DA MANEGGIARE
PRODUCT IN TWO PARTS
EASY-TO-HANDLE BOX

ACQUA
CALDA E FREDDA
WATER
HOT AND COLD

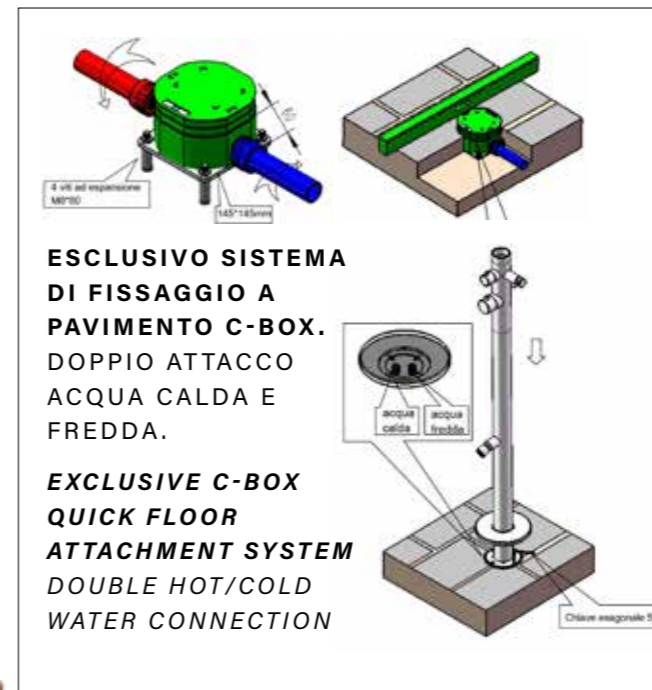

ESCLUSIVO SISTEMA
DI FISSAGGIO A
PAVIMENTO C-BOX.
DOPPIO ATTACCO
ACQUA CALDA E
FREDDA.

EXCLUSIVE C-BOX
QUICK FLOOR
ATTACHMENT SYSTEM
DOUBLE HOT/COLD
WATER CONNECTION

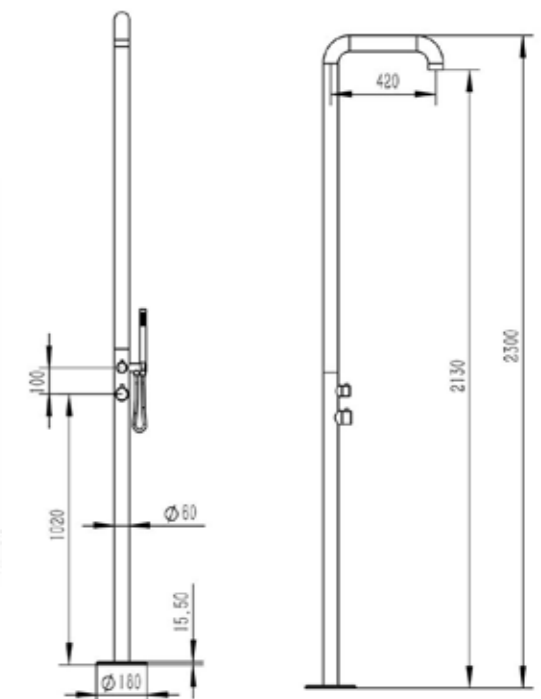

DOCCIA-OLBIA-INOX

8025431152984

MATERIALE ACCIAIO INOX 316L
MATERIAL 316L STAINLESS**UGELLI ANTICALCARE**
ANTISCALE NOZZLES**PESO 16KG**
WEIGHT 16KG**INCLUDE UNA SACCA**
DI PROTEZIONE
INCLUDES A
PROTECTION BAG**GETTO D'ACQUA**
VERTICALE
WATER JET
VERTICAL**ACCESSORI ACCIAIO INOX 304**
ACCESSORIES STAINLESS STEEL 304**PRODOTTO IN DUE**
PARTI. SCATOLA
FACILE DA MANEGGIARE
PRODUCT IN TWO PARTS
EASY-TO-HANDLE BOX**ACQUA**
CALDA E FREDDA
WATER
HOT AND COLD**IT**

Olbia Inox: Doccia Esterna In Acciaio Nautico 316l Sined Di Alta Qualità, h 243.9cm, 6cm Diametro, Con Sistema C-box Per Stabilità Superiore. Ideale Per Ambienti Marini, Giardini, Piscine. Design Elegante, Miscelatore Integrato, Resistente a Corrosione.

EN

Olbia Inox: High Quality Nautical 316l Sined Steel Outdoor Shower, h 243.9cm, 6cm Diameter, With C-box System For Superior Stability. Ideal For Marine Environments, Gardens, Swimming Pools. Elegant Design, Integrated Mixer, Corrosion Resistant.

FR

Olbia Inox : Douche d'extérieur en acier inoxydable 316l de haute qualité, h 243.9cm, 6cm de diamètre, avec système C-box pour une stabilité supérieure. Idéale pour les environnements marins, les jardins et les piscines. Design élégant, mitigeur intégré, résistant à la corrosion.

DE

Olbia Inox: Hochwertige nautische Dusche aus 316l Edelstahl für den Außenbereich, H 243,9cm, 6cm Durchmesser, mit C-Box-System für hervorragende Stabilität. Ideal für maritime Umgebungen, Gärten, Schwimmbäder. Elegantes Design, integrierter Mischer, resistente a la corrosión.

ES

Olbia Inox: Ducha de exterior de acero sinterizado 316l de alta calidad, h 243.9cm, 6cm de diámetro, con sistema C-box para una estabilidad superior. Ideal para ambientes marinos, jardines, piscinas. Diseño elegante, mezclador integrado, resistente a la corrosión.

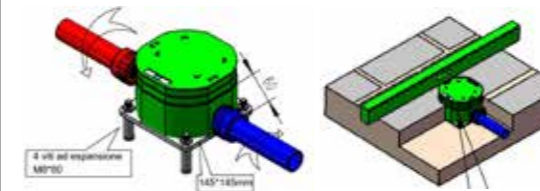
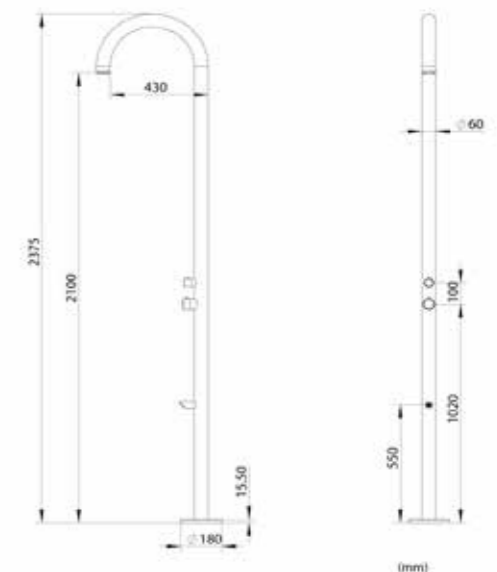
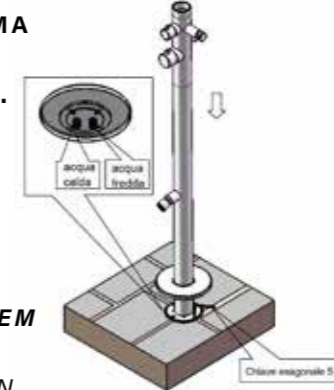
**ESCLUSIVO SISTEMA**
DI FISSAGGIO A
PAVIMENTO C-BOX.
DOPPIO ATTACCO
ACQUA CALDA E
FREDDA.**EXCLUSIVE C-BOX**
QUICK FLOOR
ATTACHMENT SYSTEM
DOUBLE HOT/COLD
WATER CONNECTION

DOCCIA-OLBIA-NERA

8025431152991

MATERIALE ACCIAIO INOX 316L
MATERIAL 316L STAINLESS**UGELLI ANTICALCARE**
ANTISCALE NOZZLES**PESO 16KG**
WEIGHT 16KG**INCLUDE UNA SACCA**
DI PROTEZIONE
INCLUDES A
PROTECTION BAG**GETTO D'ACQUA**
VERTICALE
WATER JET
VERTICAL**ACCESSORI ACCIAIO INOX 304**
ACCESSORIES STAINLESS STEEL 304**PRODOTTO IN DUE**
PARTI. SCATOLA
FACILE DA MANEGGIARE
PRODUCT IN TWO PARTS
EASY-TO-HANDLE BOX**ACQUA**
CALDA E FREDDA
WATER
HOT AND COLD**IT**

OLBIA NERA: Doccia Esterna in Acciaio nero inox 316L SINED di Alta Qualità, H 243.9cm, 6cm Diametro, con Sistema C-BOX per Stabilità Superiore. Ideale per Ambienti Marini, Giardini, Piscine. Design Elegante, Miscelatore Integrato, Resistente a Corrosione.

EN

OLBIA BLACK: High Quality Black 316L SINED Stainless Steel Outdoor Shower, H 243.9cm, 6cm Diameter, with C-BOX System for Superior Stability. Ideal for Marine Environments, Gardens, Swimming Pools. Elegant Design, Integrated Mixer, Corrosion Resistant.

FR

OLBIA BLACK : Douche d'extérieur en acier inoxydable 316L SINED de haute qualité, H 243.9cm, 6cm de diamètre, avec système C-BOX pour une stabilité supérieure. Idéale pour les environnements marins, les jardins et les piscines. Design élégant, mitigeur intégré, résistant à la corrosion.

DE

OLBIA BLACK: Hochwertige schwarze Edelstahlusche aus 316L SINED, H 243,9 cm, Durchmesser 6 cm, mit C-BOX-System für hervorragende Stabilität. Ideal für Meeresumgebungen, Gärten und Schwimmbäder. Elegantes Design,

ES

OLBIA NEGRA: Ducha exterior de acero inoxidable 316L SINED de alta calidad, H 243.9cm, 6cm de diámetro, con sistema C-BOX para una estabilidad superior. Ideal para ambientes marinos, jardines, piscinas. Diseño elegante, mezclador integrado, resistente a la corrosión.

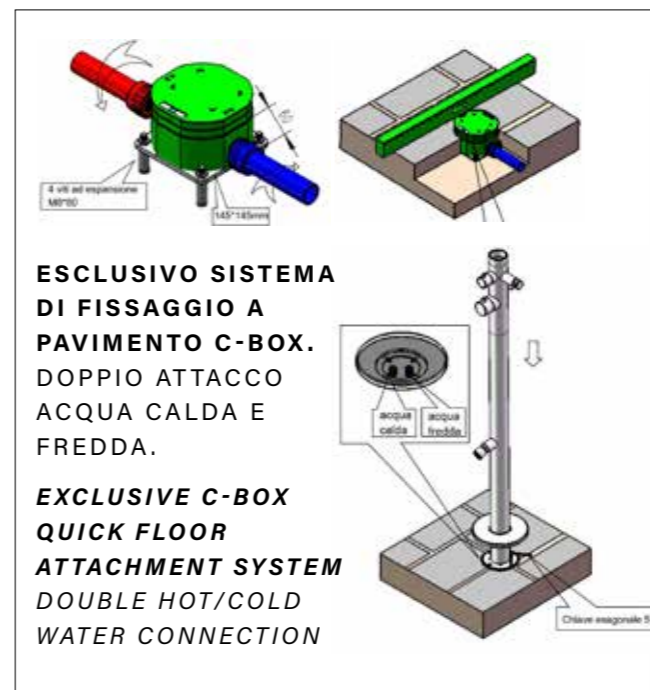
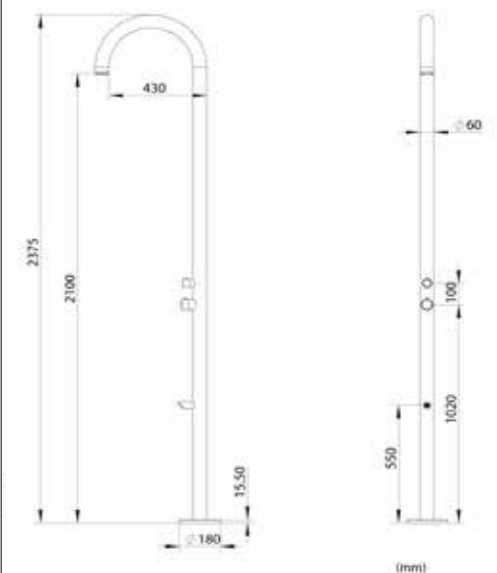
**ESCLUSIVO SISTEMA**
DI FISSAGGIO A
PAVIMENTO C-BOX.
DOPPIO ATTACCO
ACQUA CALDA E
FREDDA.**EXCLUSIVE C-BOX**
QUICK FLOOR
ATTACHMENT SYSTEM
DOUBLE HOT/COLD
WATER CONNECTION

**IT**

Doccia Da Esterno Sined Alghero In Acciaio Inox Satinato Doccia Con Miscelatore e Doccino a Mano Fusto Diametro 6 Cm Corpo Doccia Ed Accessori In Acciaio Inox Aisi 316l Doccia Con Con Ingresso Acqua Calda e Fredda Attacchi a Scomparsa Sulla Base.

EN

Outdoor Shower Sined Alghero In Satin Stainless Steel Shower With Mixer And Hand Shower 6 Cm Diameter Body Shower And Accessories In Stainless Steel Aisi 316l Shower With Hot And Cold Water Inlet Concealed Connections On The Base

FR

Sined Alghero Douche Extérieure En Acier Inox Satiné Douche Avec Mitigeur Et Douchette à Main Diamètre 6 Cm Douche De Corps Et Accessoires En Acier Inox Aisi 316l Douche Avec Arrivée D'eau Chaude Et Froide Raccordements Cachés Sur La Base

DE

Sined Alghero Außenbrause Aus Satiniertem Edelstahl Dusche Mit Mischbatterie Und Handbrause 6 Cm Durchmesser Körperbrause Und Zubehör Aus Edelstahl Aisi 316l Dusche Mit Warm- Und Kaltwasseranschluss Verdeckte Anschlüsse An Der Basis

ES

Ducha Exterior De Acero Inoxidable Satinado Sined Alghero Ducha Con Mezclador y Teleducha De 6 Cm De Diámetro Ducha Corporal y Accesorios De Acero Inoxidable Aisi 316l Ducha Con Entrada De Agua Caliente y Fría Conexiones Ocultas En La Base

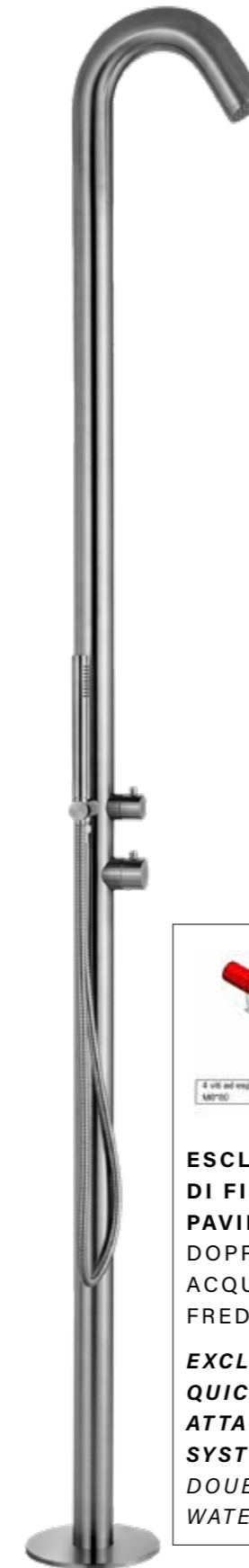
**DOCCIA-ALGHERO-INOX**

8025431016668

MATERIALE ACCIAIO INOX 316L
MATERIAL 316L STAINLESS

UGELLI ANTICALCARE
ANTISCALE NOZZLES

PESO 12,6 KG
WEIGHT 12,6 KG

INCLUDE UNA SACCA
DI PROTEZIONE
INCLUDES A
PROTECTION BAG



GETTO D'ACQUA
DIAGONALE
WATER JET
DIAGONAL



ACCESSORI ACCIAIO INOX 304
ACCESSORIES STAINLESS STEEL 304

PRODOTTO IN DUE
PARTI. SCATOLA FACILE DA
MANEGGIARE
PRODUCT IN TWO
PARTS EASY-TO-HANDLE
BOX



ACQUA
CALDA E FREDDA
WATER
HOT AND COLD

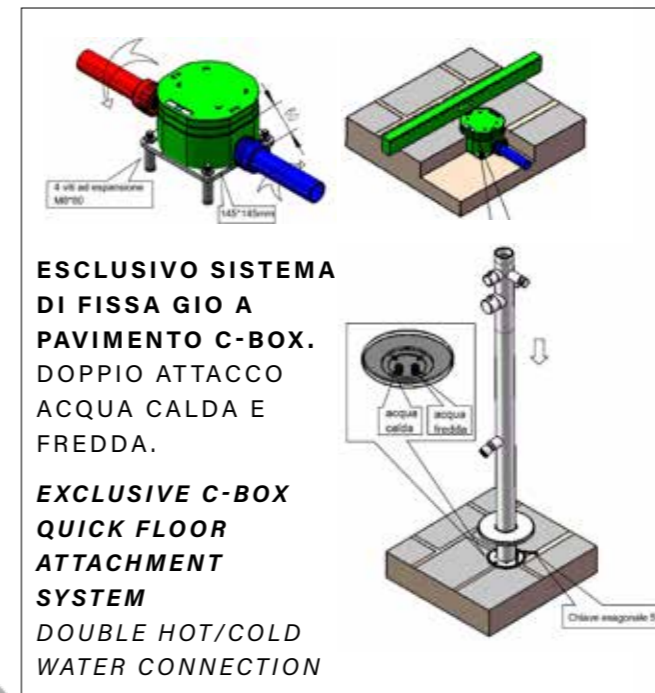

ESCLUSIVO SISTEMA
DI FISSA GIO A
PAVIMENTO C-BOX.
DOPPIO ATTACCO
ACQUA CALDA E
FREDDA.

EXCLUSIVE C-BOX
QUICK FLOOR
ATTACHMENT
SYSTEM
DOUBLE HOT/COLD
WATER CONNECTION

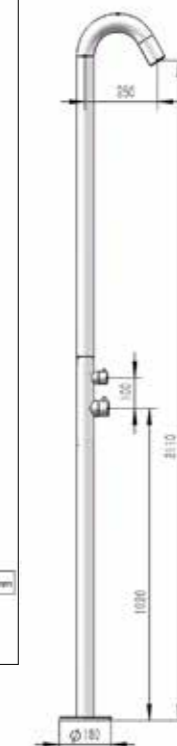

**IT**

Doccia Da Giardino Nera Sined Alghero In Acciaio Nero Opaco Doccia Con Miscelatore e Doccetta Corpo Doccia Ed Accessori In Acciaio Inox Aisi 316l Doccia Per Interno Ed Esterno Ingresso Acqua Calda e Fredda Dal Basso Fusto Diametro 60mm h 2289 Mm.

EN

Sined Alghero Black Matt Black Steel Garden Shower With Mixer and Hand Shower Body and Accessories In Stainless Steel AISI 316l Shower For Interior and Exterior Use Hot and Cold Water Inlet From Below Drum Diameter 60mm h 2289 Mm.

FR

Sined Alghero Black Matt Black Steel Garden Shower With Mixer and Hand Shower Body and Accessories In Stainless Steel AISI 316l Shower For Interior and Exterior Use Hot and Cold Water Inlet From Below Drum Diameter 60mm h 2289 Mm.

DE

Sined Alghero Schwarz Matt Schwarz Stahl Gartendusche mit Mischer und Handbrause Körper und Zubehör in Edelstahl AISI 316l Dusche für Innen- und Außenbereich verwenden Warm- und Kaltwasserzulauf von unten Trommeldurchmesser 60mm h 2289 Mm.

ES

Sined Alghero Negro Mate Ducha de Jardín en Acero Negro con Mezclador y Cuerpo de Ducha de Acero Inoxidable AISI 316l Ducha Para Uso Interior y Exterior Entrada de Agua Caliente y Fría Por Debajo Diámetro del Tambor 60mm h 2289 Mm.

DOCCIA-ALGHERO-NERA

8025431016675

MATERIALE ACCIAIO INOX 316L
MATERIAL 316L STAINLESS

UGELLI ANTICALCARE
ANTISCALE NOZZLES

PESO 12,6 KG
WEIGHT 12,6 KG

INCLUDE UNA SACCA
DI PROTEZIONE
INCLUDES A
PROTECTION BAG



GETTO D'ACQUA
VERTICALE
WATER JET
VERTICAL



ACCESSORI ACCIAIO INOX 304
ACCESSORIES STAINLESS STEEL 304



PRODOTTO IN DUE
PARTI. SCATOLA FACILE DA
MANEGGIARE
PRODUCT IN TWO
PARTS EASY-TO-HANDLE
BOX

ACQUA
CALDA E FREDDA
WATER
HOT AND COLD

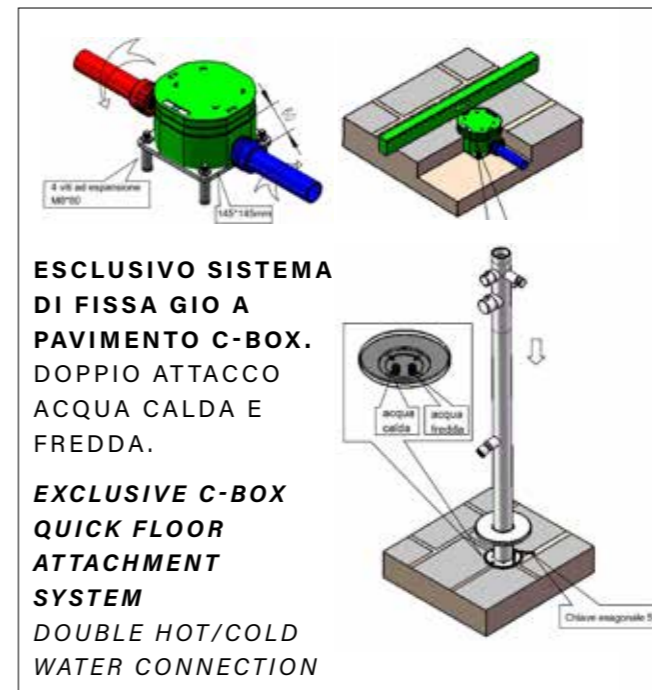

ESCLUSIVO SISTEMA
DI FISSA GIO A
PAVIMENTO C-BOX.
DOPPIO ATTACCO
ACQUA CALDA E
FREDDA.

EXCLUSIVE C-BOX
QUICK FLOOR
ATTACHMENT
SYSTEM
DOUBLE HOT/COLD
WATER CONNECTION



DOCCIA-QUARTU-INOX

8025431016835

MATERIALE ACCIAIO INOX 316L
MATERIAL 316L STAINLESS

UGELLI ANTICALCARE
ANTISCALE NOZZLES

PESO 13,6 KG
WEIGHT 13,6 KG

INCLUDE UNA SACCA
DI PROTEZIONE
INCLUDES A
PROTECTION BAG



GETTO D'ACQUA
DIAGONALE
WATER JET
DIAGONAL



ACCESSORI ACCIAIO INOX 304
ACCESSORIES STAINLESS STEEL 304

PRODOTTO IN DUE
PARTI. SCATOLA FACILE DA
MANEGGIARE
PRODUCT IN TWO
PARTS EASY-TO-HANDLE
BOX



ACQUA
CALDA E FREDDA
WATER
HOT AND COLD



IT

Doccia Per Esterni Sined Quartu In Acciaio Aisi Inox 316l Doccia Con Ingresso Acqua Calda e Fredda Fusto Diametro 60 Mm h 2289 Mm. Con Soffione Deviatore e Lavapiedi In Acciaio Aisi 316l Attacchi a Scomparsa Sulla Base Con Sistema C-box.

EN

Shower for outdoor use Sined Quartu in stainless steel Aisi 316L Shower with hot and cold water inlet Shower head diameter 60 mm H 2289 mm. with Diverter shower head and foot wash in stainless steel Aisi 316L Concealed connections on the base with C-Boxes.

FR

Douche d'extérieur Sined Quartu en acier inoxydable AISI 316L Douche avec entrée d'eau chaude et froide, diamètre de l'arbre 60 mm H 2289 mm. avec pomme de douche déviatrice et lave-pieds en acier inoxydable AISI 316L Raccordements cachés sur la base avec.

DE

Sined Quartu Außendusche Aus Edelstahl Aisi 316l Dusche Mit Warm- Und Kaltwasserzulauf 60 Mm Durchmesser Welle h 2289 Mm. Mit Kopfbrause Und Fußwaschanlage Aus Edelstahl Aisi 316l Verdeckte Anschlüsse Am Boden Mit C-box-system.

ES

Ducha Exterior Sined Quartu En Acero Inoxidable Aisi 316l Ducha Con Entrada De Agua Caliente y Fría Eje De 60 Mm De Diámetro h 2289 Mm. Con Ducha Desviadora y Lavapiés En Acero Inoxidable Aisi 316l Conexiones Ocultas En La Base Con Sistema C-box.

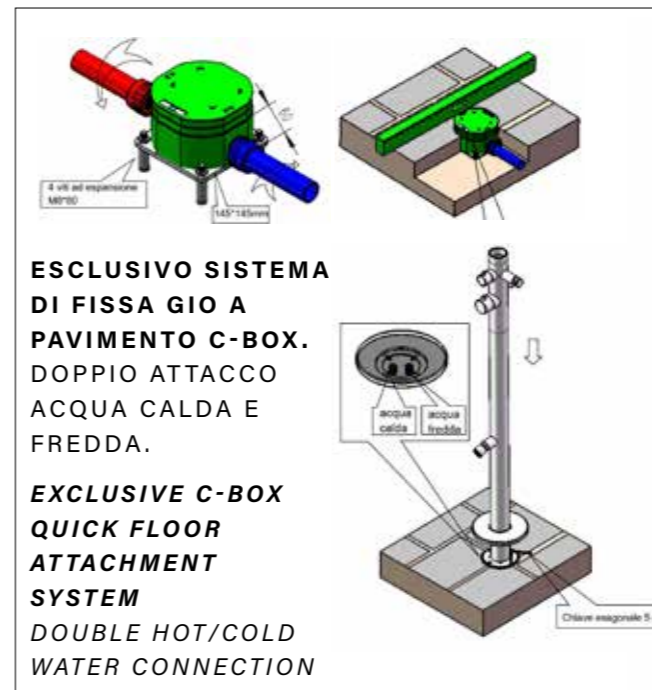
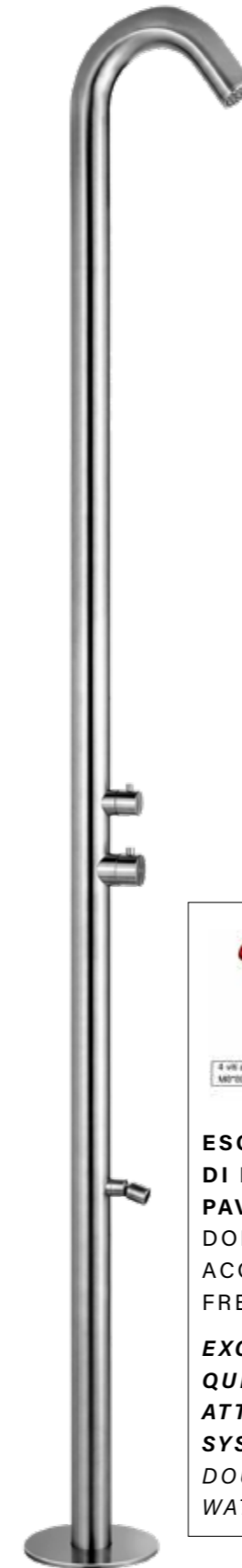

ESCLUSIVO SISTEMA
DI FISSA GIO A
PAVIMENTO C-BOX.
DOPPIO ATTACCO
ACQUA CALDA E
FREDDA.

EXCLUSIVE C-BOX
QUICK FLOOR
ATTACHMENT
SYSTEM
DOUBLE HOT/COLD
WATER CONNECTION



DOCCIA-QUARTU-NERA

8025431016743

MATERIALE ACCIAIO INOX 316L
MATERIAL 316L STAINLESS

UGELLI ANTICALCARE
ANTISCALE NOZZLES

PESO 13,6 KG
WEIGHT 13,6 KG

INCLUDE UNA SACCA
DI PROTEZIONE
INCLUDES A
PROTECTION BAG



GETTO D'ACQUA
DIAGONALE
WATER JET
DIAGONAL



ACCESSORI ACCIAIO INOX 304
ACCESSORIES STAINLESS STEEL 304

PRODOTTO IN DUE
PARTI. SCATOLA FACILE DA
MANEGGIARE
PRODUCT IN TWO
PARTS EASY-TO-HANDLE
BOX



ACQUA
CALDA E FREDDA
WATER
HOT AND COLD



IT

Doccia Per Esterni Sined Quartu In Acciaio Aisi Inox 316l Nero Opaco Matt Black Doccia Con Ingresso Acqua Calda e Fredda Fusto Diametro 60 Mm Con Soffione Deviatore e Lavapiedi In Acciaio Aisi 316l Attacchi Acqua Calda e Fredda a Scomparsa Sulla Base.

EN

Outdoor Shower Sined Quartu In Stainless Steel Aisi Inox 316l Matt Black Shower With Hot And Cold Water Inlet Shower Head Diameter 60 Mm With Diverter Shower Head And Foot Wash In Stainless Steel Aisi 316l Hot And Cold Water Connections On The Base.

FR

Douche Sined Quartu en acier inoxydable AISI 316L noir mat avec entrée d'eau chaude et froide tambour de 60 mm de diamètre avec pomme de douche à inverseur et lave-pieds en acier inoxydable AISI 316L avec pomme de douche à inverseur et lave-pieds Raccords d'eau chaude et froide sur la base.

DE

Sined Quartu Edelstahl AISI 316L Mattschwarz Dusche mit Warm- und Kaltwassereinlass 60 mm Durchmesser Trommel mit Umsteller Duschkopf und Fußwaschanlage AISI 316L Edelstahl Umsteller Duschkopf und Fußwaschanlage Warm- und Kaltwasseranschlüsse

ES

Ducha Sined Quartu Acero Inoxidable AISI 316L Negro Mate Con Entrada De Agua Caliente Y Fría Tambor De 60 mm De Diámetro Con Ducha Desviadora Y Lavapies Acero Inoxidable AISI 316L Ducha Desviadora Y Lavapies Conexiones De Agua Caliente Y Fría En La Base.

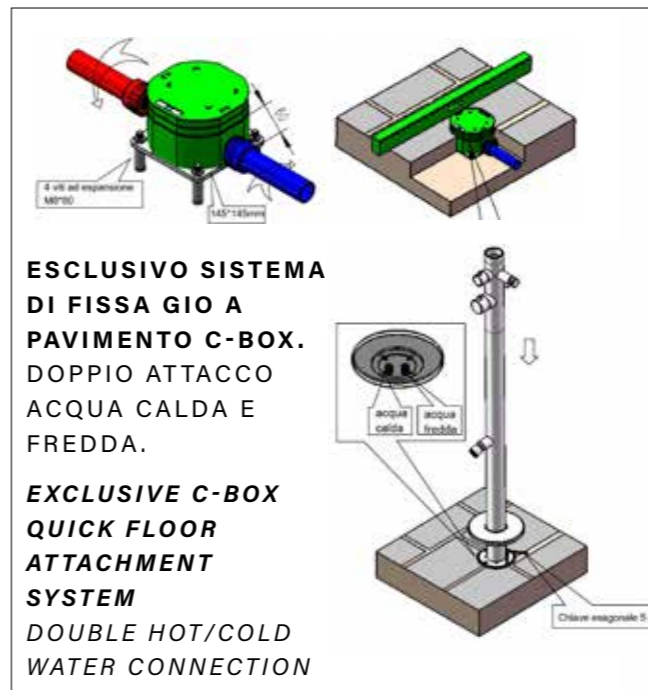

ESCLUSIVO SISTEMA
DI FISSA GIO A
PAVIMENTO C-BOX.
DOPPIO ATTACCO
ACQUA CALDA E
FREDDA.

EXCLUSIVE C-BOX
QUICK FLOOR
ATTACHMENT
SYSTEM
DOUBLE HOT/COLD
WATER CONNECTION

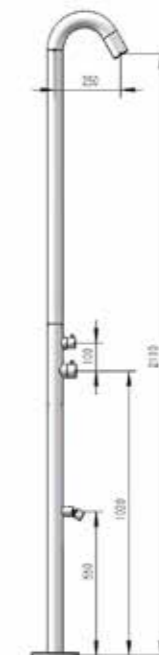

DOCCIA-QUARTU-BIANCA

8025431152977

MATERIALE ACCIAIO INOX 316L
MATERIAL 316L STAINLESS

UGELLI ANTICALCARE
ANTISCALE NOZZLES

PESO 14 KG
WEIGHT 14 KG

INCLUDE UNA SACCA
DI PROTEZIONE
INCLUDES A
PROTECTION BAG



GETTO D'ACQUA
DIAGONALE
WATER JET
DIAGONAL



ACCESSORI ACCIAIO INOX 304
ACCESSORIES STAINLESS STEEL 304

DUE FILTRI ANTICALCARE INCLUSI
TWO ANTI-SCALE FILTERS INCLUDED

FILTRO ANTICALCARE INCLUSO
FILTER LIMESCALE INCLUDED

PRODOTTO IN DUE
PARTI. SCATOLA FACILE DA
MANEGGIARE
PRODUCT IN TWO-
PARTS EASY-TO-HAN-
DLE BOX

ACQUA CALDA E FREDDA
WATER HOT AND COLD



IT

Doccia Esterna Quartu Bianca In Acciaio Inox Nautico 316l: h 228.9cm, Diametro 6cm, Finitura Bianco Opaco. Design Sofisticato, Montaggio C-box Per Stabilità e Durata. Miscelatori Per Acqua Calda/fredda e Lavapiedi Inclusi. Per Casa, Giardini, Yacht.

EN

Quartu White Nautical 316l Stainless Steel Outdoor Shower: h 228.9cm, diameter 6cm, matt white finish. Sophisticated design, C-box assembly for stability and durability. Hot/Cold Water Mixers and Foot Washers Included. For Home, Garden, Yacht.

FR

Douche d'extérieur Quartu White Nautical 316l Stainless Steel : h 228.9cm, diamètre 6cm, finition blanc mat. Design sophistiqué, assemblage en C pour la stabilité et la durabilité. Mélangeurs d'eau chaude/froide et lave-pieds inclus. Pour la maison, le jardin, le yacht.

DE

Quartu White Nautical 316l Edelstahl-Außendusche: H 228,9cm, Durchmesser 6cm, mattweißes Finish. Anspruchsvolles Design, C-Box-Montage für Stabilität und Haltbarkeit. Inklusive Warm-/Kaltwassermischer und Fußwaschanlage. Für Haus, Garten, Yacht.

ES

Ducha exterior Quartu White Nautical de acero inoxidable 316l: h 228,9cm, diámetro 6cm, acabado blanco mate. Diseño sofisticado, montaje C-box para mayor estabilidad y durabilidad. Mezcladores de agua caliente/frío y lavapiés incluidos. Para casa, jardín, yate.

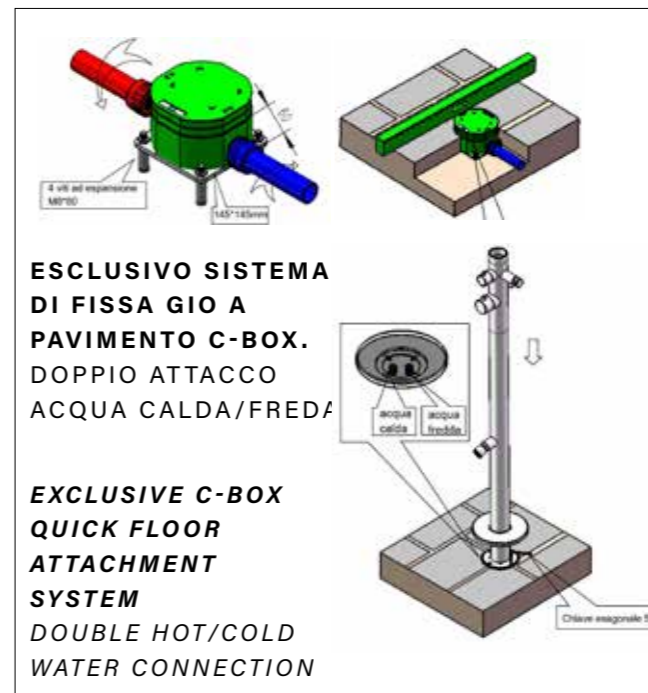

ESCLUSIVO SISTEMA
DI FISSA GIO A
PAVIMENTO C-BOX.
DOPPIO ATTACCO
ACQUA CALDA/FREDDA

EXCLUSIVE C-BOX
QUICK FLOOR
ATTACHMENT
SYSTEM
DOUBLE HOT/COLD
WATER CONNECTION

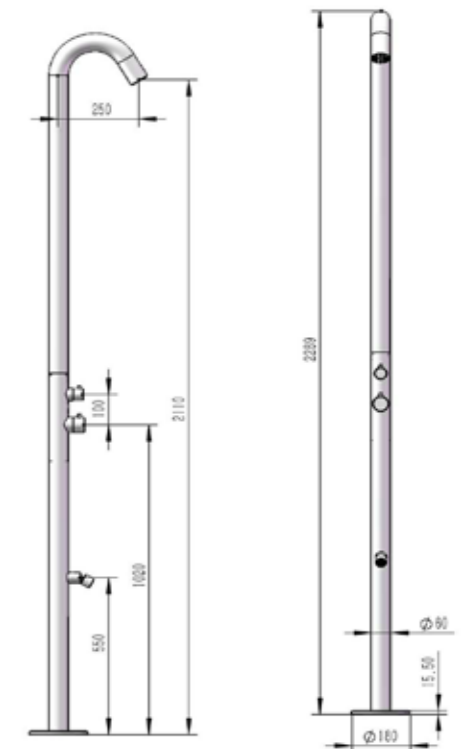

DOCCIA-QUARTU-CANNA-FUCILE

8025431019676

MATERIALE ACCIAIO INOX 316L
MATERIAL 316L STAINLESS**UGELLI ANTICALCARE**
ANTISCALE NOZZLES**PESO 13,6 KG**
WEIGHT 13,6 KG**INCLUDE UNA SACCA**
DI PROTEZIONE
INCLUDES A
PROTECTION BAG**GETTO D'ACQUA**
DIAGONALE
WATER JET
DIAGONAL**ACCESSORI ACCIAIO INOX 304**
ACCESSORIES STAINLESS STEEL 304**SPECIALE TRATTAMENTO**
VERNICIATURA PVD
SPECIAL PVD VARNISHING
TREATMENT**PRODOTTO IN DUE**
PARTI. SCATOLA FACILE DA
MANEGGIARE
PRODUCT IN TWO
PARTS EASY-TO-HANDLE
BOX**ACQUA**
CALDA E FREDDA
WATER
HOT AND COLD**IT**

Doccia Per Esterni Quartu
In Acciaio Aisi Inox 316L
Canna Di Fucile. Doccia
Con Ingresso Acqua Calda
e Fredda Fusto Diametro
60 Mm h 2289 Mm. Con
Soffione Deviatore e
Lavapiedi In Acciaio Aisi
316L Attacchi a Scomparsa
Sulla Base Con Sistema
C-box.

EN

Quartu Stainless Steel Aisi
316L Gunmetal Outdoor
Shower. Shower with Hot
and Cold Water Inlet 60 mm
diameter shaft h 2289 mm.
With Diverter Shower Head
and Foot Wash in AISI 316L
Stainless Steel. Concealed
connections on the base
with C-box system.

FR

Douche extérieure en acier
inoxydable Quartu Aisi
316L Gunmetal. Douche
avec arrivée d'eau chaude
et froide, diamètre 60 mm,
h 2289 mm, avec pomme
de douche et lave-pieds
en acier inoxydable AISI
316. Avec pomme de
douche et lave-pieds en
acier inoxydable AISI 316L.
Raccordements dissimulés
sur la base avec le système

DE

Quartu Edelstahl Aisi
316L Gunmetal Outdoor-
Dusche. Dusche mit Warm-
und Kaltwasserzulauf,
Durchmesser 60 mm,
Schacht h 2289 mm.
Mit Kopfbrause und
Fußwaschanlage aus
Edelstahl AISI 316L.
Verdeckte Anschlüsse am
Sockel mit C-Box-System.

ES

Ducha de Exterior Quartu
Acero Inoxidable Aisi 316L
Gunmetal. Ducha con
Entrada de Agua Caliente
y Fría eje de 60 mm de
diámetro h 2289 mm.
Con Ducha Desviadora
y Lavapies en Acero
Inoxidable AISI 316L.
Conexiones ocultas en la
base con sistema C-box.

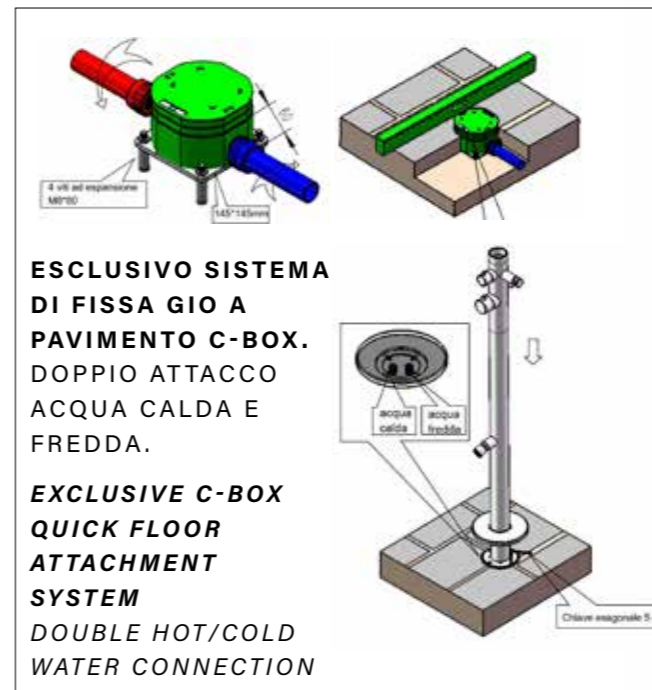
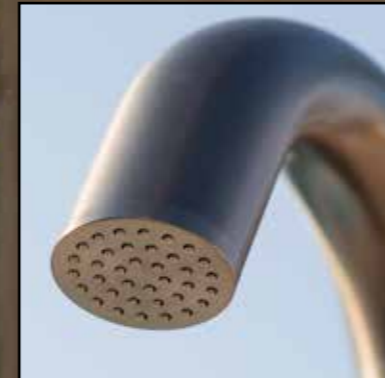
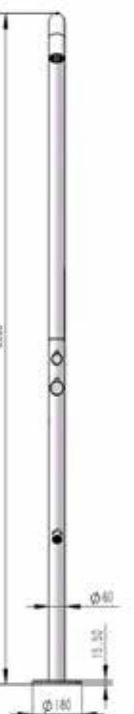
**ESCLUSIVO SISTEMA**
DI FISSA GIO A
PAVIMENTO C-BOX.
DOPPIO ATTACCO
ACQUA CALDA E
FREDDA.**EXCLUSIVE C-BOX**
QUICK FLOOR
ATTACHMENT
SYSTEM
DOUBLE HOT/COLD
WATER CONNECTION

DOCCIA-QUARTU-ORO

8025431019683

MATERIALE ACCIAIO INOX 316L
MATERIAL 316L STAINLESS

UGELLI ANTICALCARE
ANTISCALE NOZZLES

PESO 13,6 KG
WEIGHT 13,6 KG

INCLUDE UNA SACCA
DI PROTEZIONE
INCLUDES A
PROTECTION BAG



GETTO D'ACQUA
DIAGONALE
WATER JET
DIAGONAL



ACCESSORI ACCIAIO INOX 304
ACCESSORIES STAINLESS STEEL 304

SPECIALE TRATTAMENTO
VERNICIATURA PVD
SPECIAL PVD VARNISHING
TREATMENT

PRODOTTO IN DUE
PARTI. SCATOLA FACILE DA
MANEGGIARE
PRODUCT IN TWO
PARTS EASY-TO-HANDLE
BOX



ACQUA
CALDA E FREDDA
WATER
HOT AND COLD



IT

Doccia Per Esterno Quartu
In Acciaio Aisi Inox 316l Oro
Spazzolato Doccia Brushed
Gold Ingresso Acqua Calda
e Fredda Fusto Diametro
60 Mm h 2289 Mm. Con
Soffione Deviatore e
Lavapiedi In Acciaio Aisi
316l Attacchi a Scomparsa
Sulla Base Con Sistema
C-box.

EN

Quartu Outdoor Shower
In Brushed Gold Aisi Inox
316l Steel. Shower With Hot
And Cold Water Inlet Drum
Diameter 60 Mm h 2289
Mm. With Diverter Head
Shower And Foot Wash In
Steel Aisi 316l Concealed
Connections On The Base
With C-box System.

FR

Douche Quartu en acier
inoxydable Aisi 316l Gold
Brushed Gold avec arrivée
d'eau chaude et froide
diamètre 60 mm axe h
2289 mm. Avec pomme de
douche orientable et lave-
pieds en acier inoxydable
Aisi 316l. Connexions
dissimulées sur la base
avec système C-box.

DE

Quartu Edelstahl Aisi 316l
Gold Gebürstetes Gold
Dusche mit Warm-und
Kaltwasserzulauf 60 mm
Durchmesser Welle h
2289 mm. Mit Kopfbrause
und Fußwaschanlage
aus Edelstahl Aisi 316l
Verdeckte Anschlüsse am
Sockel mit C-Box-System.

ES

Quartu Ducha En Acero
Inoxidable Aisi 316l Oro
Cepillado Con Entrada De
Agua Caliente Y Fría Eje
De 60 mm De Diámetro
H 2289 mm. Con Ducha
Desviadora y Lavapies En
Acero Inoxidable Aisi 316l
Conexiones Ocultas En
Base Con Sistema C-box.

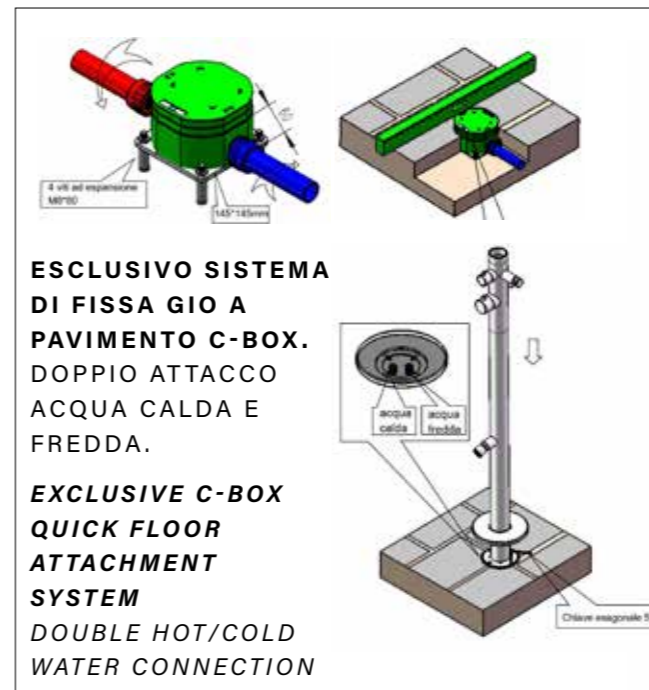

ESCLUSIVO SISTEMA
DI FISSA GIO A
PAVIMENTO C-BOX.
DOPPIO ATTACCO
ACQUA CALDA E
FREDDA.

EXCLUSIVE C-BOX
QUICK FLOOR
ATTACHMENT
SYSTEM
DOUBLE HOT/COLD
WATER CONNECTION

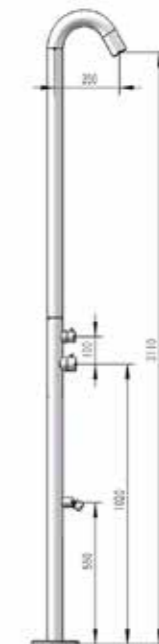

DOCCIA-QUARTU-ORO-ROSA

8025431019690

MATERIALE ACCIAIO INOX 316L
MATERIAL 316L STAINLESS

UGELLI ANTICALCARE
ANTISCALE NOZZLES

PESO 13,6 KG
WEIGHT 13,6 KG

INCLUDE UNA SACCA
DI PROTEZIONE
INCLUDES A
PROTECTION BAG



GETTO D'ACQUA
DIAGONALE
WATER JET
DIAGONAL



ACCESSORI ACCIAIO INOX 304
ACCESSORIES STAINLESS STEEL 304

SPECIALE TRATTAMENTO
VERNICIATURA PVD
SPECIAL PVD VARNISHING
TREATMENT

PRODOTTO IN DUE
PARTI. SCATOLA FACILE DA
MANEGGIARE
PRODUCT IN TWO
PARTS EASY-TO-HANDLE
BOX



ACQUA
CALDA E FREDDA
WATER
HOT AND COLD

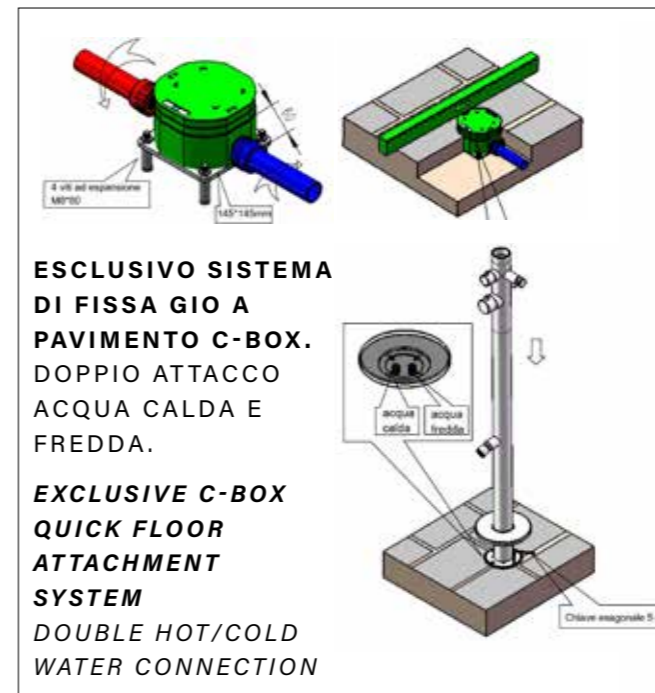

ESCLUSIVO SISTEMA
DI FISSA GIO A
PAVIMENTO C-BOX.
DOPPIO ATTACCO
ACQUA CALDA E
FREDDA.

EXCLUSIVE C-BOX
QUICK FLOOR
ATTACHMENT
SYSTEM
DOUBLE HOT/COLD
WATER CONNECTION

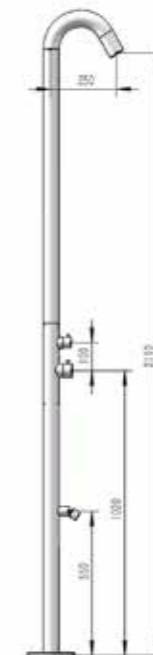

IT

Doccia Per Esterno Quartu
 In Acciaio Aisi Inox 316l
 Oro Rpsa. Doccia Rose
 Gold Con Ingresso Acqua
 Calda e Fredda Fusto
 Diametro 60 Mm h 2289
 Mm. Con Soffione Deviatore
 e Lavapiedi In Acciaio Aisi
 316l Attacchi a Scomparsa
 Sulla Base Con Sistema
 C-box.

EN

Quartu Stainless Steel Aisi
 316l Gold Rpsa Outdoor
 Shower. Rose Gold Shower
 with Hot and Cold Water
 Inlet 60 mm diameter
 shaft h 2289 mm. With
 Diverter Shower Head and
 Foot Wash in Stainless
 Steel Aisi 316l. Concealed
 connections on the base
 with C-box system.

FR

Douche d'extérieur Quartu en
 acier inoxydable Aisi 316l Gold
 Rpsa. Douche en or rose avec
 arrivée d'eau chaude et froide,
 diamètre 60 mm, h 2289 mm,
 avec pomme de douche et
 lave-pieds en acier inoxydable
 Aisi 316l. Avec pomme de
 douche orientable et lave-pieds
 en acier inoxydable Aisi 316l.
 Connexions dissimulées sur la
 base avec le système C-box.

DE

Quartu Edelstahl Aisi
 316l Gold Rpsa Outdoor
 Dusche. Rose Gold
 Dusche mit Warm- und
 Kaltwasserzulauf 60 mm
 Durchmesser Welle h
 2289 mm. Mit Kopfbrause
 und Fußwaschanlage
 aus Edelstahl Aisi 316l.
 Verdeckte Anschlüsse
 an der Basis mit C-Box-

ES

Ducha Exterior Quartu
 Acero Inoxidable Aisi
 316l Oro Rpsa. Ducha
 Oro Rosa con Entrada de
 Agua Caliente y Fría eje
 de 60 mm de diámetro
 h 2289 mm. Con Ducha
 Desviadora y Lavapies en
 Acero Inoxidable Aisi 316l.
 Conexiones ocultas en la
 base con sistema C-box.

**IT**

Doccia In Acciaio Inox Stintino Struttura e Rubinetteria In Acciaio Inox Satinato Aisi 316l Acciaio Marino. Soffione Orientabile Lavapiedi e Doccino a Mano Con Tubo Flessibile Doccia Tradizionale Ad Acqua Calda e Fredda Con Attacchi a Scomparsa.

EN

Stainless Steel Shower Stintino Satin Stainless Steel Structure and Fittings Aisi 316l Stainless Steel Marine. Swivel Shower Head Foot Wash and Hand Shower With Flexible Hose Traditional Hot and Cold Water Shower With Concealed Connections.

FR

Douche en acier inoxydable Stintino Structure et raccords en acier inoxydable satiné Aisi 316l Marine Steel. Pomme de douche orientable Lavapieds et douchette à main avec tuyau flexible Douche traditionnelle à eau chaude et froide avec raccords dissimulés.

DE

Edelstahl Dusche Stintino Satin Edelstahl Struktur und Armaturen Aisi 316l Edelstahl Marine. Drehbarer Duschkopf Fußwäsche und Handbrause mit flexiblem Schlauch Traditionelle Warm- und Kaltwasserdusche mit verdeckten Anschlüssen.

ES

Ducha De Acero Inoxidable Stintino Estructura Y Accesorios De Acero Inoxidable Aisi 316l Marino. Ducha Giratoria Lava Pies y Teleducha Con Manguera Flexible Ducha Tradicional De Agua Fría y Caliente Con Conexiones Ocultas.

DOCCIA-STINTINO-INOX

8025431016774

MATERIALE ACCIAIO INOX 316L
MATERIAL 316L STAINLESS

UGELLI ANTICALCARE
ANTISCALE NOZZLES

PESO 13,6KG
WEIGHT 13,6 KG

INCLUDE UNA SACCA
DI PROTEZIONE
INCLUDES A
PROTECTION BAG



GETTO D'ACQUA
DIAGONALE
WATER JET
DIAGONAL



ACCESSORI ACCIAIO INOX 304
ACCESSORIES STAINLESS STEEL 304

PRODOTTO IN DUE
PARTI. SCATOLA FACILE DA
MANEGGIARE
PRODUCT IN TWO
PARTS EASY-TO-HANDLE
BOX



ACQUA
CALDA E FREDDA
WATER
HOT AND COLD

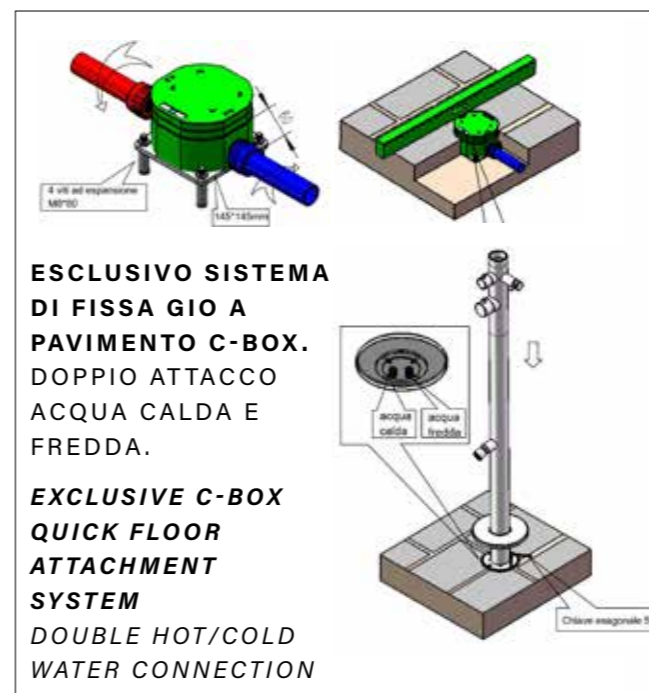

ESCLUSIVO SISTEMA
DI FISSA GIO A
PAVIMENTO C-BOX.
DOPPIO ATTACCO
ACQUA CALDA E
FREDDA.

EXCLUSIVE C-BOX
QUICK FLOOR
ATTACHMENT
SYSTEM
DOUBLE HOT/COLD
WATER CONNECTION

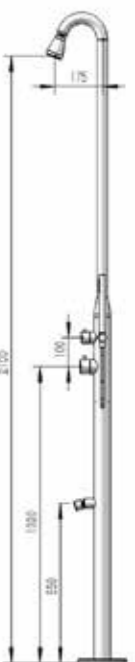

DOCCIA-STINTINO-NERA

8025431016842

MATERIALE ACCIAIO INOX 316L
MATERIAL 316L STAINLESS

UGELLI ANTICALCARE
ANTISCALE NOZZLES

PESO 13,6 KG
WEIGHT 13,6 KG

INCLUDE UNA SACCA
DI PROTEZIONE
INCLUDES A
PROTECTION BAG



GETTO D'ACQUA
DIAGONALE
WATER JET
DIAGONAL



ACCESSORI ACCIAIO INOX 304
ACCESSORIES STAINLESS STEEL 304

PRODOTTO IN DUE
PARTI. SCATOLA FACILE DA
MANEGGIARE
PRODUCT IN TWO
PARTS EASY-TO-HANDLE
BOX



ACQUA
CALDA E FREDDA
WATER
HOT AND COLD



IT

Doccia Per Esterno
Sined Stintino Struttura
e Rubinetteria In Acciaio
Inox Aisi 316l, Marino. Nero
Opaco Matte Black Doccia
Con Ingresso Acqua Calda
e Fredda Con Deviatore
Per Soffione Orientabile
Lavapiedi e Doccino a
Mano Con Tubo Flessibile
Black.

EN

Outdoor Shower Sined
Stintino Structure and
Fittings In Stainless Steel
Aisi 316l, Marine. Matte
Black Shower With Hot
And Cold Water Inlet With
Diverter For Swivel Shower
Head Foot Wash And Hand
Shower With Flexible Black
Hose.

FR

Douche extérieure avec
structure et accessoires en
acier inoxydable Aisi 316l,
Marine. Douche noire mate
avec arrivée d'eau chaude
et froide avec inverseur
pour tête de douche
orientable, lave-pieds et
douchette à main avec
tuyau flexible noir.

DE

Outdoor-Dusche
Sined Stintino Struktur
und Armaturen aus
Edelstahl Aisi 316l,
Marine. Mattschwarze
Dusche mit Warm- und
Kaltwassereinlass mit
Umsteller für schwenkbaren
Duschkopf Fußwäsche und
Handbrause mit flexiblem
schwarzem Schlauch.

ES

Ducha Exterior Sined
Stintino Estructura Y
Accesorios En Acero
Inoxidable Aisi 316l,
Marino. Ducha En Negro
Mate Con Entrada De
Agua Caliente Y Fría Con
Desviador Para Rociador
Giratorio Lava Pies Y
Teleducha Con Manguera
Negra Flexible.

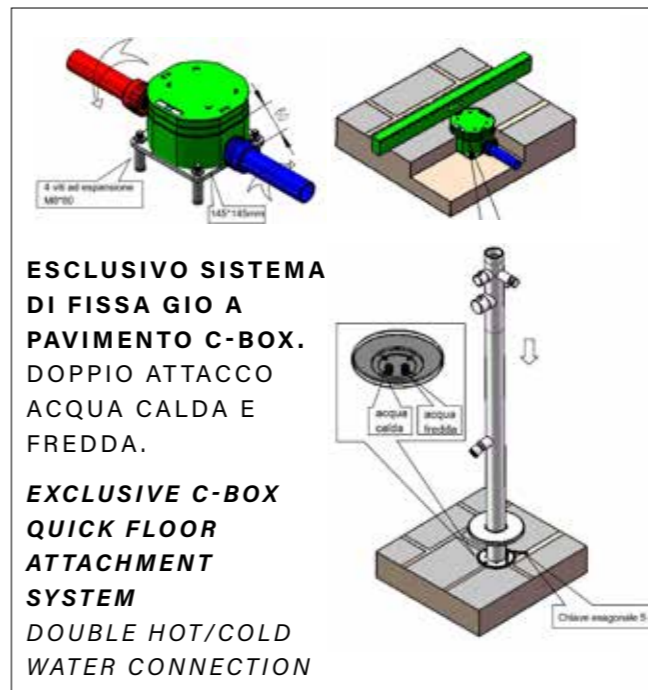
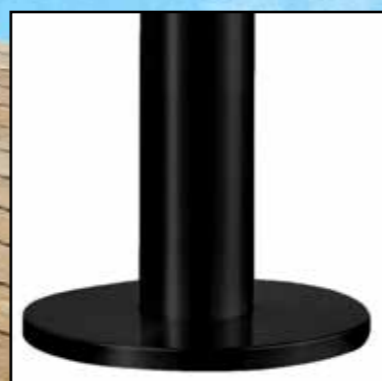
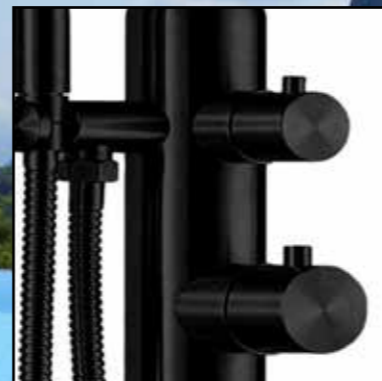

ESCLUSIVO SISTEMA
DI FISSA GIO A
PAVIMENTO C-BOX.
DOPPIO ATTACCO
ACQUA CALDA E
FREDDA.

EXCLUSIVE C-BOX
QUICK FLOOR
ATTACHMENT
SYSTEM
DOUBLE HOT/COLD
WATER CONNECTION

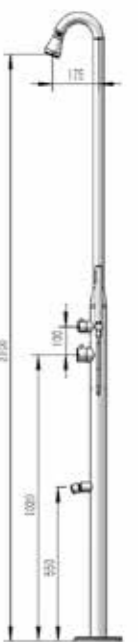

DOCCIA-BOSA-INOX

8025431016682

MATERIALE ACCIAIO INOX 316L
MATERIAL 316L STAINLESS

UGELLI ANTICALCARE
ANTISCALE NOZZLES

PESO 14 KG
WEIGHT 14 KG

INCLUDE UNA SACCA
DI PROTEZIONE
INCLUDES A
PROTECTION BAG



GETTO D'ACQUA
VERTICALE
WATER JET
VERTICAL



ACCESSORI ACCIAIO INOX 304
ACCESSORIES STAINLESS STEEL 304

PRODOTTO IN DUE
PARTI. SCATOLA FACILE DA
MANEGGIARE
PRODUCT IN TWO
PARTS EASY-TO-HANDLE
BOX



ACQUA
CALDA E FREDDA
WATER
HOT AND COLD



IT

Doccia Per Piscina Sined Bosa In Acciaio Satinato Aisi Inox 316l Doccia Con Ingresso Acqua Calda e Fredda Fusto Diametro 60 Mm Miscelatore a 3 Vie Per Soffione Doccetta a Mano e Lavapiedi Attacchi a Scomparsa Sulla Base Rubinetteria In Acciaio Aisi 316l.

EN

Shower for swimming pool Sined Bosa in Satin Stainless Steel Aisi Inox 316L Shower with hot and cold water inlet Shower head diameter 60 mm 3 ways mixer for shower head Hand shower and foot wash basin Concealed connections on the base Fittings in Stainless.

FR

Douche De Piscine Sined Bosa En Acier Inox Satiné Aisi Inox 316l Douche Avec Entrée D'eau Chaude Et Froide Arbre De 60 Mm De Diamètre Mitigeur 3 Voies Pour Douche De Tête Douche à Main Et Lavapieds Raccords Cachés Sur La Base Raccords En Acier Inox Aisi.

DE

Schwimmbaddusche Sined Bosa aus satiniertem Edelstahl Aisi Inox 316L Dusche mit Warm- und Kaltwasseranschluss Welle mit 60 mm Durchmesser 3-Wege-Mischer für Kopfbrause Handbrause und Fußwaschbecken Verdeckte Anschlüsse am Sockel Armaturen aus

ES

Ducha de piscina Sined Bosa en acero inoxidable satinado Aisi Inox 316L Ducha con entrada de agua caliente y fría Eje de 60 mm de diámetro Mezclador de 3 vías para ducha superior Ducha de mano y lavabo de pie Conexiones ocultas en la base Grifería en acer.

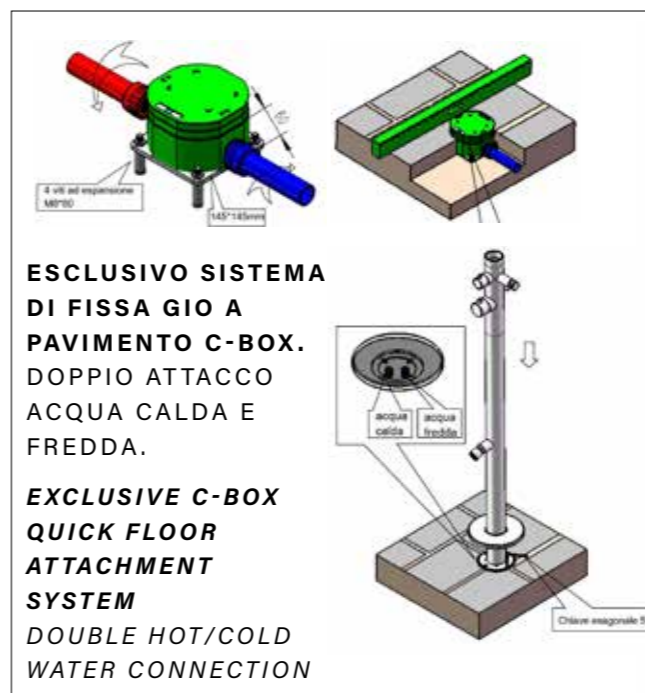
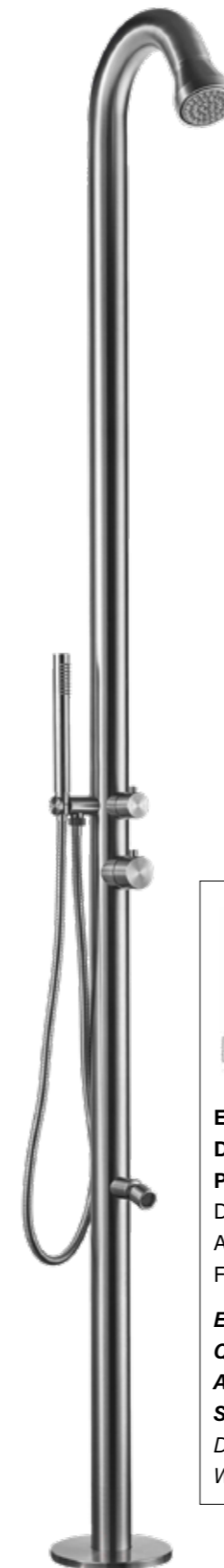
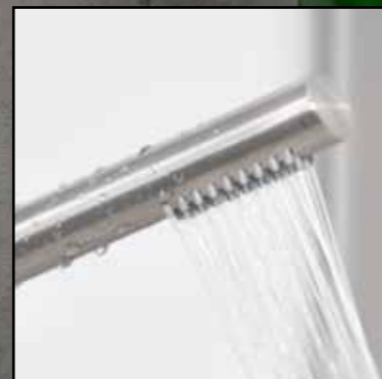

ESCLUSIVO SISTEMA
DI FISSA GIO A
PAVIMENTO C-BOX.
DOPPIO ATTACCO
ACQUA CALDA E
FREDDA.

EXCLUSIVE C-BOX
QUICK FLOOR
ATTACHMENT
SYSTEM
DOUBLE HOT/COLD
WATER CONNECTION

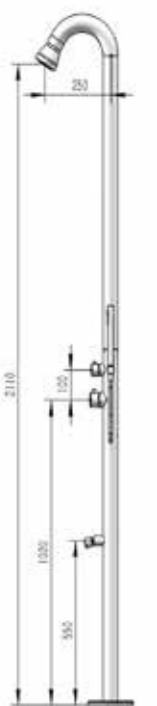

DOCCIA-BOSA-NERA

8025431016699

MATERIALE ACCIAIO INOX 316L
MATERIAL 316L STAINLESS

UGELLI ANTICALCARE
ANTISCALE NOZZLES

PESO 14 KG
WEIGHT 14 KG

INCLUDE UNA SACCA
DI PROTEZIONE
INCLUDES A
PROTECTION BAG



GETTO D'ACQUA
VERTICALE
WATER JET
VERTICAL



ACCESSORI ACCIAIO INOX 304
ACCESSORIES STAINLESS STEEL 304

PRODOTTO IN DUE
PARTI. SCATOLA FACILE DA
MANEGGIARE
PRODUCT IN TWO
PARTS EASY-TO-HANDLE
BOX



ACQUA
CALDA E FREDDA
WATER
HOT AND COLD



IT

Doccia Da Interno e Esterno Sined Bosa In Acciaio Aisi Inox 316l Nero e Rubinetteria In Acciaio Aisi 316l Fusto Diametro 60 Mm Con Soffione e Deviatore Per Doccetta a Mano e Lavapiedi Doccia Black Matt Ingresso Acqua Calda e Fredda Sulla Base h 2289 Mm.

EN

Sined Bosa Indoor And Outdoor Shower In Black Aisi 316l Stainless Steel And Aisi 316l Stainless Steel Taps 60 Mm Diameter Shaft With Shower Head And Diverter For Hand Shower And Foot Shower Shower With Hot And Cold Water Inlet On Base h 2289 Mm.

FR

Douche intérieure et extérieure Sined Bosa en acier inoxydable Aisi 316L et robinetterie en acier inoxydable Aisi 316L Arbre de 60 mm de diamètre avec douche de tête et inverseur pour douche à main et lavapieds Douche avec entrée d'eau chaude et froide.

DE

Sined Bosa Innen- Und Außendusche Aus Schwarzem Edelstahl Aisi 316l Und Armaturen Aus Edelstahl Aisi 316l Schaftdurchmesser 60 Mm Mit Kopfbrause Und Umsteller Für Hand- Und Fußbrause Dusche Mit Warm- Und Kaltwasseranschluss Am

ES

Ducha interior y exterior Sined Bosa de acero inoxidable Aisi 316L negro y grifería de acero inoxidable Aisi 316L Eje de 60 mm de diámetro con ducha superior y desviador para teleducha y lavapiés Doucha con entrada de agua caliente y fría en la base H 2289.

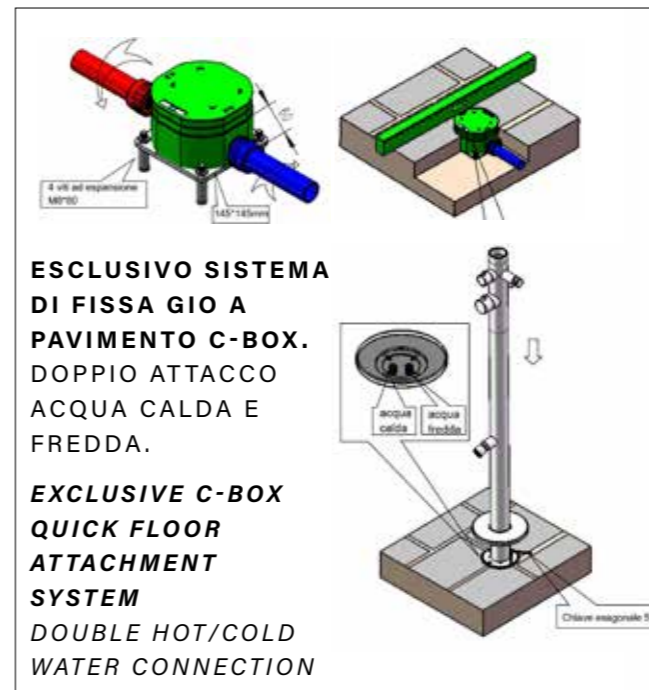
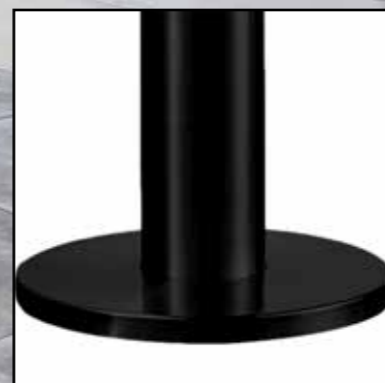

ESCLUSIVO SISTEMA
DI FISSA GIO A
PAVIMENTO C-BOX.
DOPPIO ATTACCO
ACQUA CALDA E
FREDDA.

EXCLUSIVE C-BOX
QUICK FLOOR
ATTACHMENT
SYSTEM
DOUBLE HOT/COLD
WATER CONNECTION

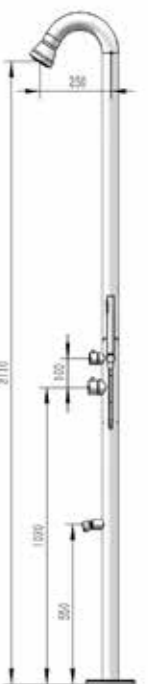

DOCCIA-BUDONI-INOX

8025431016705

MATERIALE ACCIAIO INOX 316L
MATERIAL 316L STAINLESS**UGELLI ANTICALCARE**
ANTISCALE NOZZLES**PESO 10,3 KG**
WEIGHT 10,3 KG**INCLUDE UNA SACCA**
DI PROTEZIONE
INCLUDES A
PROTECTION BAG**GETTO D'ACQUA**
VERTICALE
WATER JET
VERTICAL**ACCESSORI ACCIAIO INOX 304**
ACCESSORIES STAINLESS STEEL 304**PRODOTTO IN DUE**
PARTI. SCATOLA FACILE DA
MANEGGIARE
PRODUCT IN TWO
PARTS EASY-TO-HANDLE
BOX**ACQUA**
CALDA E FREDDA
WATER
HOT AND COLD**IT**

Doccia Esterna Sined Budoni In Acciaio Inox Satinato Doccia Da Giardino Con Ingresso Acqua Calda e Fredda Miselatore e Doccino a Mano Corpo e Accessori In Acciaio Inox Aisi 316L Con Fusto Diametro 6 Cm. Attacchi a Scomparsa Nella Base.

EN

Sined Budoni Outdoor Shower In Satin Stainless Steel Garden Shower With Hot And Cold Water Inlet Mixer And Hand Shower Body And Accessories In Stainless Steel Aisi 316L With Shaft Diameter 6 Cm. Concealed Connections In The Base.

FR

Sined Budoni Douche D'extérieur En Acier Inox Satiné Douche De Jardin Avec Entrée D'eau Chaude Et Froide Douche à Main Et Mélangeur Corps Et Accessoires En Acier Inox Aisi 316L Avec Tige De 6 Cm De Diamètre. Connexions Dissimulées Dans La Base.

DE

Sined Budoni Außendusche Aus Satiniertem Edelstahl Gartendusche Mit Warm-Und Kaltwasseranschluss Handbrause Und Mischbatterie Körper Und Zubehör Aus Edelstahl Aisi 316L Mit Welle Mit 6 Cm Durchmesser. Verdeckte Anschlüsse Im Sockel.

ES

Ducha Exterior De Acero Inoxidable Satinado Sined Budoni Ducha De Jardín Con Entrada De Agua Caliente y Fría Ducha De Mano y Mezclador Cuerpo y Accesorios De Acero Inoxidable Aisi 316L Con Eje De 6 Cm De Diámetro. Conexiones Ocultas En La Base.

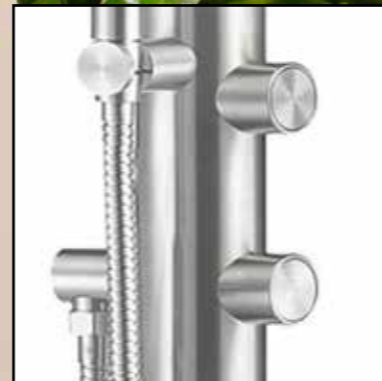
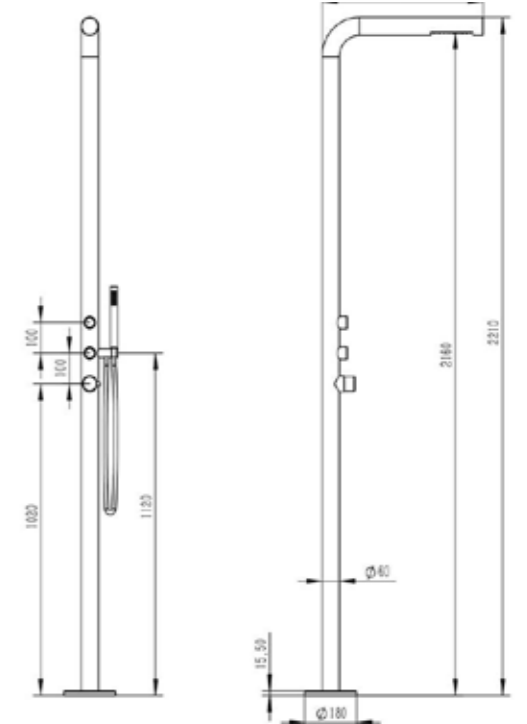
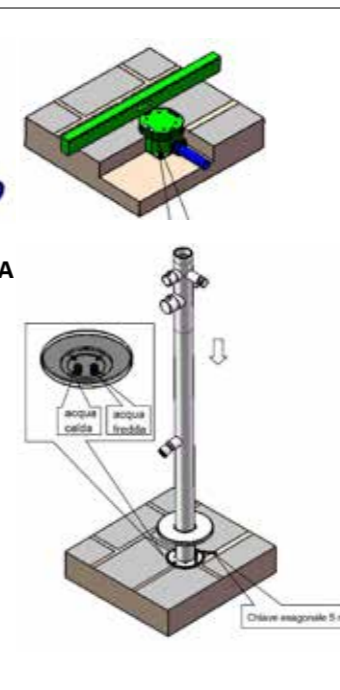
**ESCLUSIVO SISTEMA**
DI FISSA GIO A
PAVIMENTO C-BOX.
DOPPIO ATTACCO
ACQUA CALDA E
FREDDA.**EXCLUSIVE C-BOX**
QUICK FLOOR
ATTACHMENT
SYSTEM
DOUBLE HOT/COLD
WATER CONNECTION

DOCCIA-BUDONI-NERA

8025431016798

MATERIALE ACCIAIO INOX 316L
MATERIAL 316L STAINLESS**UGELLI ANTICALCARE**
ANTISCALE NOZZLES**PESO 10,3 KG**
WEIGHT 10,3 KG**INCLUDE UNA SACCA**
DI PROTEZIONE
INCLUDES A
PROTECTION BAG**GETTO D'ACQUA**
VERTICALE
WATER JET
VERTICAL**ACCESSORI ACCIAIO INOX 304**
ACCESSORIES STAINLESS STEEL 304**PRODOTTO IN DUE**
PARTI. SCATOLA FACILE DA
MANEGGIARE
PRODUCT IN TWO
PARTS EASY-TO-HANDLE
BOX**ACQUA**
CALDA E FREDDA
WATER
HOT AND COLD**IT**

Doccia Da Giardino Sined Budoni Nera Doccia Con Miscelatore e Doccetta Corpo e Accessori In Acciaio Inox Aisi 316l Nero Opaco Fusto Diametro 6 Cm Doccia Per Interno Ed Esterno Con Con Ingresso Acqua Calda e Fredda Dal Basso. h 2210 Mm.

EN

Garden Shower Sined Budoni Nera Shower With Mixer And Handshower Body And Accessories In Stainless Steel Aisi 316l Black Matt Drum Diameter 6 Cm Shower For Indoor And Outdoor With Hot And Cold Water Inlet From The Bottom. h 2210 Mm.

FR

Douche De Jardin Sined Budoni Nera Douche Avec Mitigeur Et Douchette Corps Et Accessoires En Acier Inox Aisi 316l Noir Mat Diamètre Du Corps 6 Cm Douche Pour Intérieur Et Extérieur Avec Arrivée D'eau Chaude Et Froide Par Le Bas. h 2210 Mm.

DE

Gartendusche Sined Budoni Nera Dusche Mit Mischbatterie Und Handbrause Körper Und Zubehör Aus Edelstahl Aisi 316l Mattschwarz Körperdurchmesser 6 Cm Dusche Für Den Innen- Und Außenbereich Mit Warm- Und Kaltwasseranschluss Von Unten. h 2210 Mm.

ES

Ducha de jardín Sined Budoni Nera Ducha con mezclador y teleducha Cuerpo y accesorios en acero inoxidable AISI 316L negro mate Diámetro del cuerpo 6 cm Ducha para uso interior y exterior con entrada de agua caliente y fría por la parte inferior. H 2210 mm.

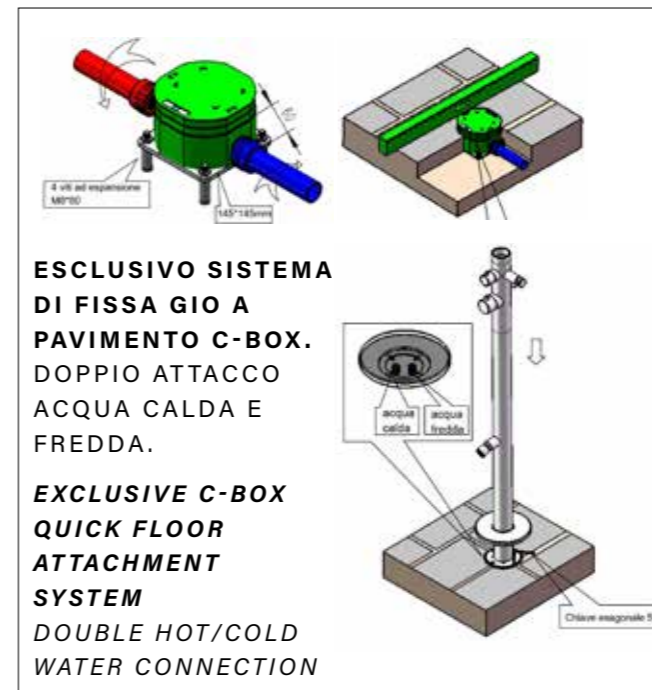
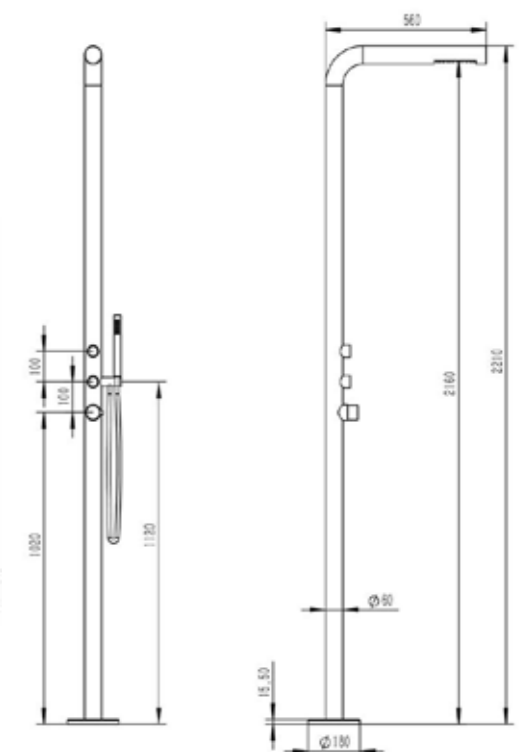
**ESCLUSIVO SISTEMA**
DI FISSA GIO A
PAVIMENTO C-BOX.
DOPPIO ATTACCO
ACQUA CALDA E
FREDDA.**EXCLUSIVE C-BOX**
QUICK FLOOR
ATTACHMENT
SYSTEM
DOUBLE HOT/COLD
WATER CONNECTION

**IT**

Doccia Da Esterno Pula Sined Doccia Per Piscina e Giardino. Soffione Diametro 25cm Struttura e Accessori In Acciaio Inox Marino Aisi 316l Fusto Diametro 6 Cm In Doccia Con Alimentazione Acqua Calda e Fredda Miscelatore e Doccino a Mano h 230 Cm.

EN

Outdoor Shower Pula Sined Shower For Swimming Pool And Garden. Shower Head Diameter 25cm Structure And Accessories In Marine Stainless Steel Aisi 316l Drum Diameter 6 Cm In Shower With Hot And Cold Water Supply Hand Shower And Mixer h 230 Cm.

FR

Pula Sined Douche Extérieure Pour Piscine Et Jardin. Pomme De Douche Diamètre 25 Cm Structure Et Accessoires En Acier Inox Marine Aisi 316l Pomme De Douche Diamètre 6 Cm Avec Alimentation En Eau Chaude Et Froide Douchette à Main Et Mitigeur h 230 Cm.

DE

Pula Sined Außendusche Für Schwimmbad Und Garten. Brausekopf Durchmesser 25 Cm Struktur Und Zubehör Aus Rostfreiem Stahl Aisi 316l Brausekopf Durchmesser 6 Cm Mit Warm- Und Kaltwasserzufuhr Handbrause Und Mischer h 230 Cm.

ES

Ducha Exterior Pula Sined Para Piscina y Jardín. Ducha De 25 Cm De Diámetro Estructura y Accesorios De Acero Inoxidable Marino Aisi 316l Ducha De 6 Cm De Diámetro Con Suministro De Agua Caliente y Fría Ducha De Mano y Mezclador h 230 Cm.

DOCCIA-PULA-INOX

8025431016781

MATERIALE ACCIAIO INOX 316L
MATERIAL 316L STAINLESS

UGELLI ANTICALCARE
ANTISCALE NOZZLES

PESO 15,5 KG
WEIGHT 15,5 KG

INCLUDE UNA SACCA
DI PROTEZIONE
INCLUDES A
PROTECTION BAG



GETTO D'ACQUA
VERTICALE
WATER JET
VERTICAL



ACCESSORI ACCIAIO INOX 304
ACCESSORIES STAINLESS STEEL 304

PRODOTTO IN DUE
PARTI. SCATOLA FACILE DA
MANEGGIARE
PRODUCT IN TWO
PARTS EASY-TO-HANDLE
BOX



ACQUA
CALDA E FREDDA
WATER
HOT AND COLD

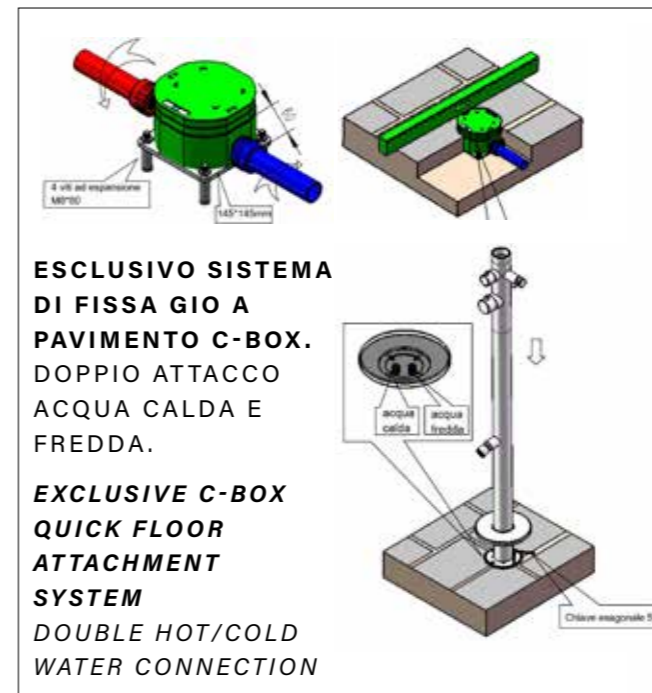

ESCLUSIVO SISTEMA
DI FISSA GIO A
PAVIMENTO C-BOX.
DOPPIO ATTACCO
ACQUA CALDA E
FREDDA.

EXCLUSIVE C-BOX
QUICK FLOOR
ATTACHMENT
SYSTEM
DOUBLE HOT/COLD
WATER CONNECTION

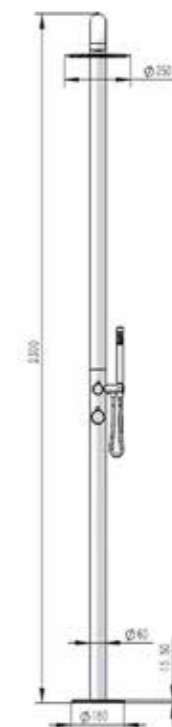

**IT**

Doccia Per Piscina Pula Nera Con Soffione Diametro 25 Cm Doccia Da Giardino Con Miscelatore e Doccetta a Mano Corpo e Accessori In Acciaio Inox Marino Aisi 316L. Doccia Con Alimentazione Acqua Calda e Fredda Attacchi a Scomparsa Nella Base.

EN

Shower For Swimming Pool Pula Nera With Shower Head Diameter 25 Cm Garden Shower With Mixer And Hand Shower Body And Accessories In Marine Stainless Steel Aisi 316L. Shower With Hot And Cold Water Supply Concealed Connections In The Base.

FR

Douche de piscine Pula Nera avec pomme de douche de 25 cm de diamètre Douche de jardin avec mitigeur et douchette à main Corps et accessoires en acier inox marine AISI 316L. Douche avec alimentation en eau chaude et froide Raccordements cachés dans la bas.

DE

Schwimmbaddusche Pula Nera Mit Kopfbrause Mit 25 Cm Durchmesser Gartendusche Mit Mischbatterie Und Handbrause Körper Und Zubehör Aus Rostfreiem Edelstahl Aisi 316L. Dusche Mit Warm- Und Kaltwasseranschluss Verdeckte Anschlüsse Im

ES

Ducha De Piscina Pula Nera Con Rociador De 25 Cm De Diámetro Ducha De Jardín Con Mezclador y Teleducha Cuerpo y Accesorios En Acero Inoxidable Marino Aisi 316L. Ducha Con Suministro De Agua Caliente y Fría Conexiones Ocultas En La Base.

**DOCCIA-PULA-NERA**

8025431016828

MATERIALE ACCIAIO INOX 316L
MATERIAL 316L STAINLESS

UGELLI ANTICALCARE
ANTISCALE NOZZLES

PESO 15,5 KG
WEIGHT 15,5 KG

INCLUDE UNA SACCA
DI PROTEZIONE
INCLUDES A
PROTECTION BAG



GETTO D'ACQUA
VERTICALE
WATER JET
VERTICAL



ACCESSORI ACCIAIO INOX 304
ACCESSORIES STAINLESS STEEL 304



PRODOTO IN DUE
PARTI. SCATOLA FACILE DA
MANEGGIARE
PRODUCT IN TWO
PARTS EASY-TO-HANDLE
BOX

ACQUA
CALDA E FREDDA
WATER
HOT AND COLD

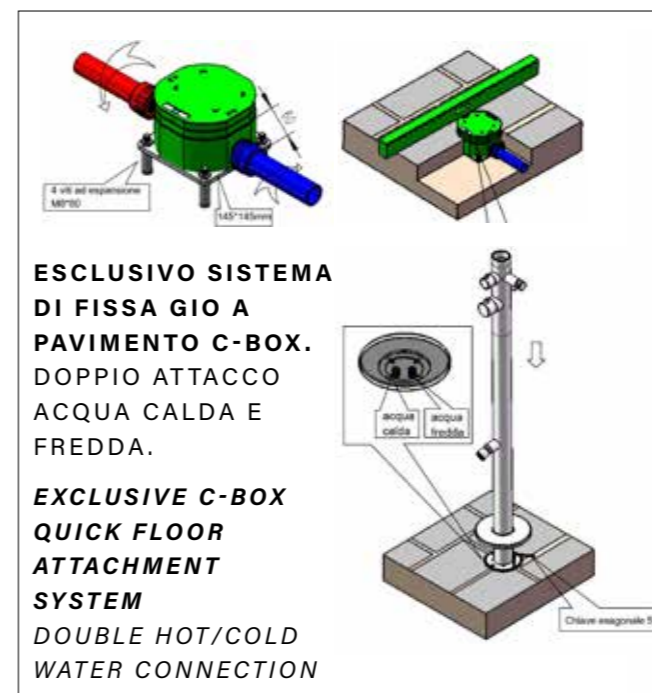

ESCLUSIVO SISTEMA
DI FISSA GIO A
PAVIMENTO C-BOX.
DOPPIO ATTACCO
ACQUA CALDA E
FREDDA.

EXCLUSIVE C-BOX
QUICK FLOOR
ATTACHMENT
SYSTEM
DOUBLE HOT/COLD
WATER CONNECTION



DOCCIA-SASSARI-INOX

8025431016750

MATERIALE ACCIAIO INOX 316L
MATERIAL 316L STAINLESS**UGELLI ANTICALCARE**
ANTISCALE NOZZLES**PESO 9,3 KG**
WEIGHT 9,3 KG**INCLUDE UNA SACCA**
DI PROTEZIONE
INCLUDES A
PROTECTION BAG**GETTO D'ACQUA**
CONTINUO
WATER JET
CONTINUOUS**ACCESSORI ACCIAIO INOX 304**
ACCESSORIES STAINLESS STEEL 304**PRODOTTO IN DUE**
PARTI. SCATOLA FACILE DA
MANEGGIARE
PRODUCT IN TWO
PARTS EASY-TO-HANDLE
BOX**ACQUA**
CALDA E FREDDA
WATER
HOT AND COLD**IT**

Doccia Per Esterni Sassari
In Acciaio Inox Satinato
Doccia Da Giardino Sined
Con Ingresso Acqua Calda
e Fredda Miscelatore e
Doccino a Mano Corpo e
Accessori In Acciaio Inox
Marino Aisi 316l Con Fusto
Diametro 6 Cm Attacchi
Acqua a Scomparsa.

EN

Sassari Satin-finish
Stainless Steel Outdoor
Shower Sined Garden
Shower with Hot and Cold
Water Inlet Mixer and
Hand Shower Body and
Accessories in AISI 316L
Marine Grade Stainless
Steel with 6 cm diameter
shaft and concealed water
connections.

FR

Douche d'extérieur en
acier inoxydable satiné
Sassari Douche d'extérieur
avec mitigeur d'entrée
d'eau chaude et froide,
corps de douche à main
et accessoires en acier
inoxydable AISI 316L de
qualité marine avec tige
de 6 cm de diamètre et
raccords d'eau dissimulés.

DE

Sassari Gartendusche
aus satiniertem Edelstahl
für den Warm- und
Kaltwasserzulauf,
Handbrause und Zubehör
aus rostfreiem Edelstahl
AISI 316L mit einem
Schaftdurchmesser von
6 cm und verdeckten
Wasseranschlüssen.

ES

Ducha de exterior de
acero inoxidable acabado
satinado Sassari Ducha
de jardín sined con
mezclador de entrada
de agua caliente y fría
y cuerpo de ducha de
mano y accesorios en
acero inoxidable de grado
marino AISI 316L con
eje de 6 cm de diámetro
y conexiones de agua

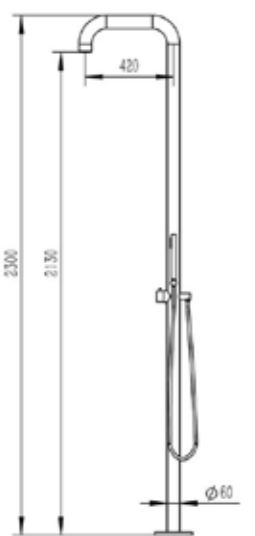
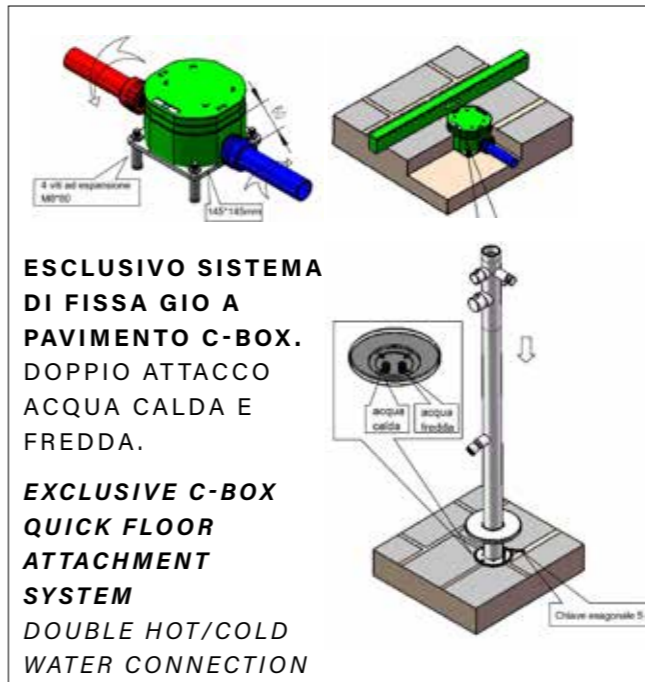
**ESCLUSIVO SISTEMA**
DI FISSA GIO A
PAVIMENTO C-BOX.
DOPPIO ATTACCO
ACQUA CALDA E
FREDDA.**EXCLUSIVE C-BOX**
QUICK FLOOR
ATTACHMENT
SYSTEM
DOUBLE HOT/COLD
WATER CONNECTION

DOCCIA-PALAU-INOX

8025431016736

MATERIALE ACCIAIO INOX 316L
MATERIAL 316L STAINLESS

UGELLI ANTICALCARE
ANTISCALE NOZZLES

PESO 16 KG
WEIGHT 16 KG

INCLUDE UNA SACCA
DI PROTEZIONE
INCLUDES A
PROTECTION BAG



GETTO D'ACQUA
VERTICALE
WATER JET
VERTICAL



ACCESSORI ACCIAIO INOX 304
ACCESSORIES STAINLESS STEEL 304



PRODOTTO IN DUE
PARTI. SCATOLA FACILE DA
MANEGGIARE
PRODUCT IN TWO
PARTS EASY-TO-HANDLE
BOX

ACQUA
CALDA E FREDDA
WATER
HOT AND COLD

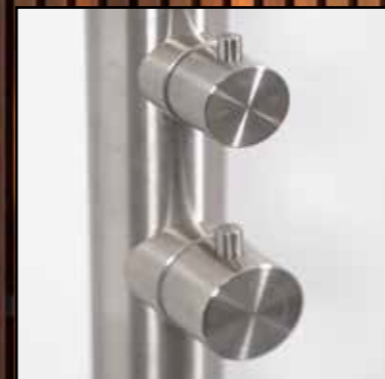

IT

Doccia Palau Sined Per
Interno Ed Esterno Con
Soffione Diametro 25 Cm
Struttura e Accessori In
Acciaio Inox Aisi 316L,
Acciaio Marino. Fusto
Diametro 6 Cm In Doccia
Con Alimentazione Acqua
Calda e Fredda Dotata Di
Miscelatore e Lavapiedi.

EN

Palau Sined Shower For
Indoor And Outdoor
Use With Shower Head
Diameter 25 Cm Structure
And Accessories In
Stainless Steel Aisi 316L,
Marine Steel. Shower Shaft
Diameter 6 Cm With Hot
And Cold Water Supply,
Equipped With Mixer And
Foot-washing System.

FR

Palau Douche Sined pour
intérieur et extérieur avec
pomme de douche de 25
cm de diamètre Structure
et accessoires en acier
inoxydable AISI 316L, acier
marin. Pomme de douche
de 6 cm de diamètre avec
alimentation en eau chaude
et froide équipée d'un
mélangeur.

DE

Palau Sined Dusche
für den Innen- und
Außenbereich mit 25 cm
Durchmesser Duschkopf
Struktur und Zubehör
aus Edelstahl AISI 316L,
Marinestahl. Duschkopf
mit einem Durchmesser
von 6 cm mit Warm- und
Kaltwasserversorgung,
ausgestattet mit Mischer

ES

Ducha Palau Sined para
uso interior y exterior con
cabezal de ducha de 25
cm de diámetro Estructura
y Accesorios en Acero
Inoxidable AISI 316L, acero
marino. Ducha de 6 cm de
diámetro con suministro
de agua caliente y fría
equipada con mezclador y
lavapie.

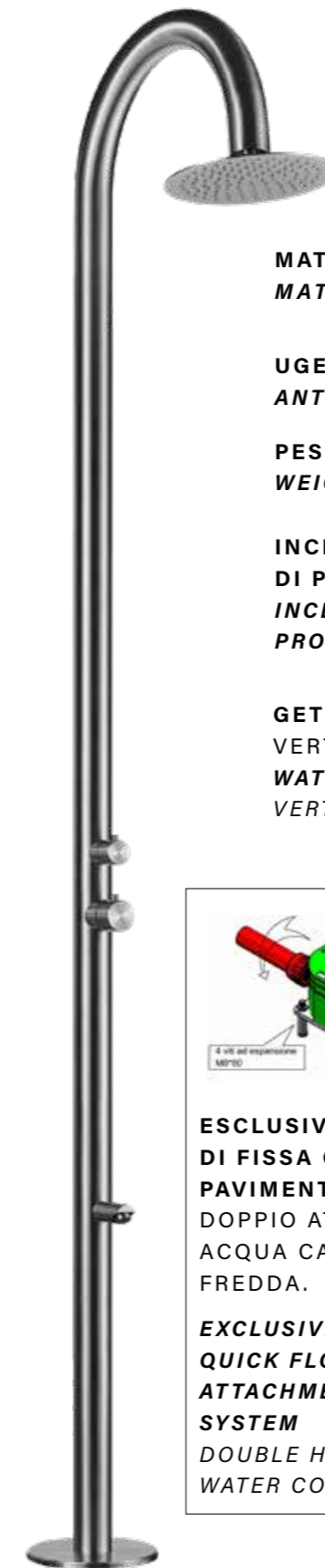

ESCLUSIVO SISTEMA
DI FISSA GIO A
PAVIMENTO C-BOX.
DOPPIO ATTACCO
ACQUA CALDA E
FREDDA.

EXCLUSIVE C-BOX
QUICK FLOOR
ATTACHMENT
SYSTEM
DOUBLE HOT/COLD
WATER CONNECTION

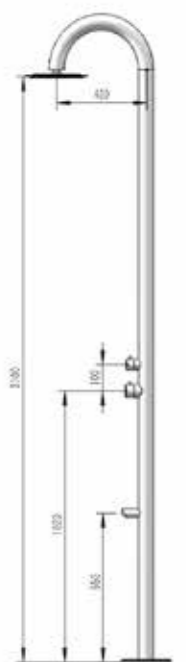
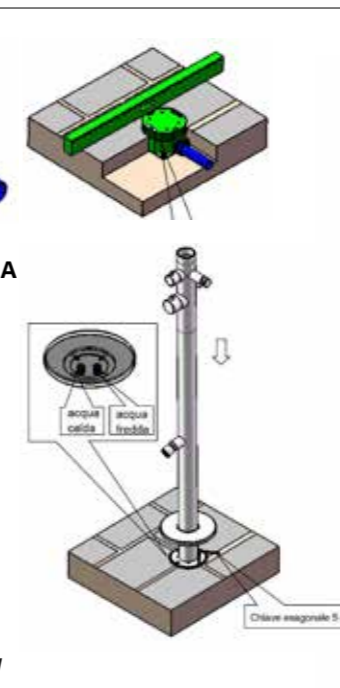

**IT**

Doccia Sined Palau Nera
Con Soffione Diametro
25cm Doccia Per Interno
Ed Esterno Con Miscelatore
e Lavapiedi Corpo e
Accessori In Acciaio Inox
Aisi 316l, Acciaio Marino.
Doccia Con Alimentazione
Acqua Calda e Fredda
Attacchi Nella Base.

EN

Shower Sined Palau
Nera With Shower Head
Diameter 25cm Shower For
Indoor And Outdoor With
Mixer Tap And Foot Wash
Body And Accessories In
Stainless Steel Aisi 316l,
Marine Steel. Shower With
Hot And Cold Water Supply
Connections In The Base.

FR

Sined Palau Noir Douche
Avec Pomme De Douche
Diamètre 25cm Douche
Pour Intérieur Et Extérieur
Avec Mitigeur Et Lave-
pieds Corps Et Accessoires
En Acier Inox Aisi 316l,
Acier Marin. Douche
Avec Alimentation En
Eau Chaude Et Froide
Connexions Dans La Base.

DE

Sined Palau Black
Dusche Mit Duschkopf
Durchmesser 25cm
Dusche Für Den Innen-
Und Außenbereich
Mit Mischbatterie Und
Fußwaschbecken Körper
Und Zubehör Aus Edelstahl
Aisi 316l, Marine Steel.
Dusche Mit Warm- Und
Kaltwasseranschluss

ES

Ducha Sined Palau Negra
Con Ducha De Diámetro
25cm Ducha Para Uso
Interior y Exterior Con
Grifo Mezclador y Lavapiés
Cuerpo y Accesorios En
Acero Inoxidable Aisi 316l,
Acero Marino. Ducha
Con Suministro De Agua
Caliente y Fría Conexiones
En La Base.

**DOCCIA-PALAU-NERA**

8025431016804

MATERIALE ACCIAIO INOX 316L
MATERIAL 316L STAINLESS

UGELLI ANTICALCARE
ANTISCALE NOZZLES

PESO 16 KG
WEIGHT 16 KG

INCLUDE UNA SACCA
DI PROTEZIONE
INCLUDES A
PROTECTION BAG



GETTO D'ACQUA
VERTICALE
WATER JET
VERTICAL



ACCESSORI ACCIAIO INOX 304
ACCESSORIES STAINLESS STEEL 304

PRODOTTO IN DUE
PARTI. SCATOLA FACILE DA
MANEGGIARE
PRODUCT IN TWO
PARTS EASY-TO-HANDLE
BOX



ACQUA
CALDA E FREDDA
WATER
HOT AND COLD

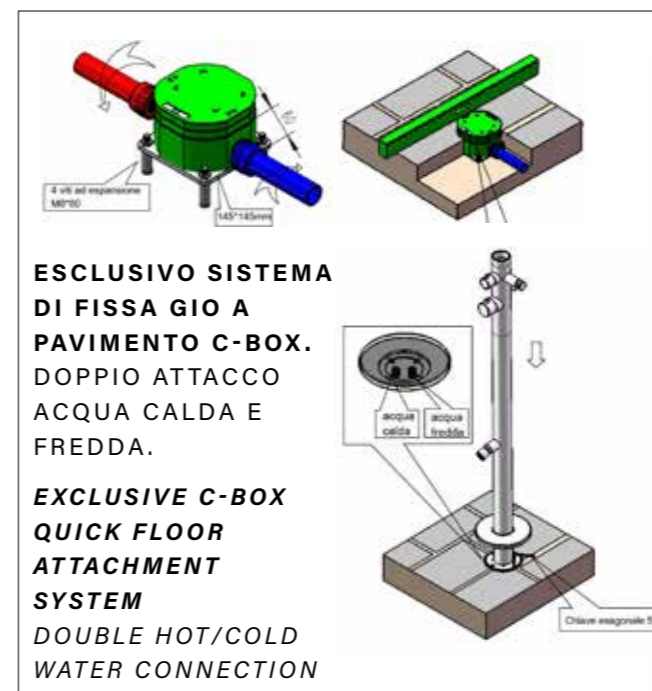

ESCLUSIVO SISTEMA
DI FISSA GIO A
PAVIMENTO C-BOX.
DOPPIO ATTACCO
ACQUA CALDA E
FREDDA.

EXCLUSIVE C-BOX
QUICK FLOOR
ATTACHMENT
SYSTEM
DOUBLE HOT/COLD
WATER CONNECTION

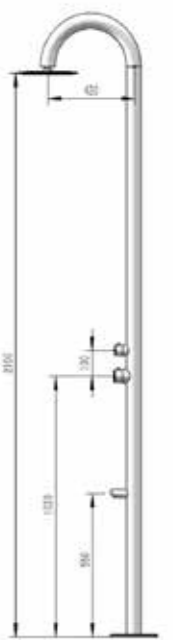



IT

Doccia Inox Di Qualita Solo Acqua Fredda Per Piscine Giardini e Spiagge Sined Modello Palau. Struttura e Accessori In Acciaio Inox Aisi 316l, Acciaio Marino. Fusto Diametro 6 Cm. Alimentazione Solo Acqua Fredda. Resistente Agenti Atmosferici e Salsedine.

EN

Quality Stainless Shower Only Cold Water For Swimming Pools Gardens And Beaches Sined Model Palau. Structure And Accessories In Aisi 316l Stainless Steel, Marine Steel. Drum Diameter 6 Cm. Cold Water Only Supply. Weather And Salt Resistant.

FR

Sined Palau modèle eau froide uniquement douche en acier inoxydable de qualité pour piscines, jardins et plages. Structure et accessoires en acier inoxydable AISI 316L, acier marin. Diamètre du tambour 6 cm. Alimentation en eau froide uniquement. Résistan.

DE

Sined Palau Modell Kaltwasser Nur Qualität Edelstahl Dusche Für Schwimmbäder Gärten Und Strände. Struktur Und Zubehör Aus Rostfreiem Stahl Aisi 316l, Marinestahl. Trommeldurchmesser 6 Cm. Nur Kaltwasserversorgung. Wetterfest Und Salzbeständig.

ES

Sined modelo Palau ducha de acero inoxidable de calidad solo agua fría para piscinas jardines y playas. Estructura y accesorios de acero inoxidable AISI 316L, acero marino. Diámetro del tambor 6 cm. Sólo suministro de agua fría. Resistente a la intemperie.

DOCCIA-PALAU-FREDDA

8025431150959

MATERIALE ACCIAIO INOX 316L
MATERIAL 316L STAINLESS

UGELLI ANTICALCARE
ANTISCALE NOZZLES

PESO 16 KG
WEIGHT 16 KG

INCLUDE UNA SACCA
DI PROTEZIONE
INCLUDES A
PROTECTION BAG



GETTO D'ACQUA
VERTICALE
WATER JET
VERTICAL



ACCESSORI ACCIAIO INOX 304
ACCESSORIES STAINLESS STEEL 304

PRODOTTO IN DUE
PARTI. SCATOLA FACILE DA
MANEGGIARE
PRODUCT IN TWO
PARTS EASY-TO-HANDLE
BOX



ACQUA FREDDA
WATER COLD

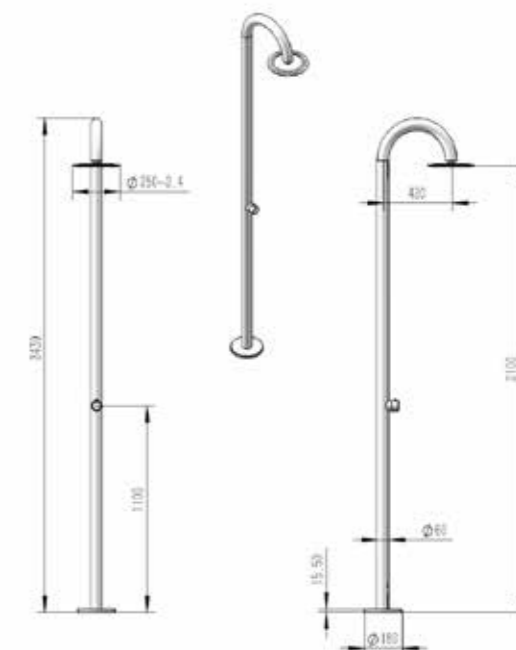
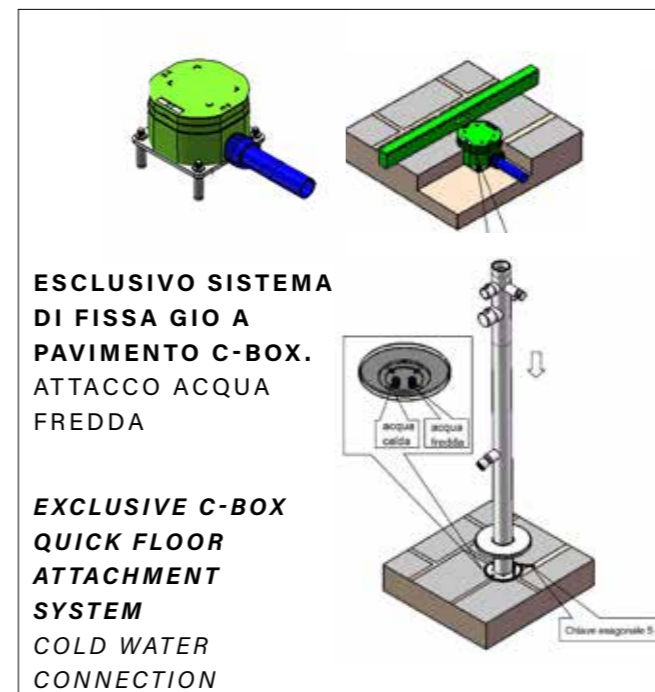



IT

Doccia In Acciaio Inox Satinato Sined Simius
 Doccia Per Giardino e Piscina a Sola Acqua Fredda
 Struttura e Accessori In Acciaio Inox Marino Aisi 316l
 Con Soffione Diametro 20 Cm Fusto Diametro 38 Mm
 Altezza 2300 Mm.

EN

Satin Stainless Steel Shower Sined Simius Cold Water Shower for Garden and Pool Structure and Accessories in Aisi 316l Marine Stainless Steel with Shower Head Diameter 20 cm Drum Diameter 38 mm Height 2300 mm.

FR

Douche en acier inoxydable satiné Sined Simius Douche à eau froide pour structure et accessoires de jardin et piscine en acier inoxydable marin Aisi 316l Avec tête de douche Diamètre 20 cm Diamètre du tambour 38 mm Hauteur 2300 mm.

DE

Sined Satin Edelstahl Dusche Sined Simius Kaltwasserdusche für Garten und Pool Struktur und Zubehör in Aisi 316l Marine Edelstahl mit Duschkopf Durchmesser 20 cm Trommeldurchmesser 38 mm Höhe 2300 mm.

ES

Ducha de Acero Inoxidable Satinado Sined Simius Ducha de Agua Fría para Jardín y Piscina Estructura y Accesorios en Acero Inoxidable Marino Aisi 316l con Cabezal de Ducha Diámetro 20 cm Tambor Diámetro 38 mm Altura 2300 mm.

DOCCIA-SIMIUS-INOX

8025431016767

MATERIALE ACCIAIO INOX 316L
MATERIAL 316L STAINLESS

UGELLI ANTICALCARE
ANTISCALE NOZZLES

PESO 18,9 KG
WEIGHT 18,9 KG

INCLUDE UNA SACCA DI PROTEZIONE
INCLUDES A PROTECTION BAG



GETTO D'ACQUA VERTICALE
WATER JET VERTICAL



ACCESSORI ACCIAIO INOX 304
ACCESSORIES STAINLESS STEEL 304

PRODOTTO IN DUE PARTI. SCATOLA FACILE DA MANEGGIARE
PRODUCT IN TWO PARTS EASY-TO-HANDLE BOX



ACQUA FREDDA
WATER COLD

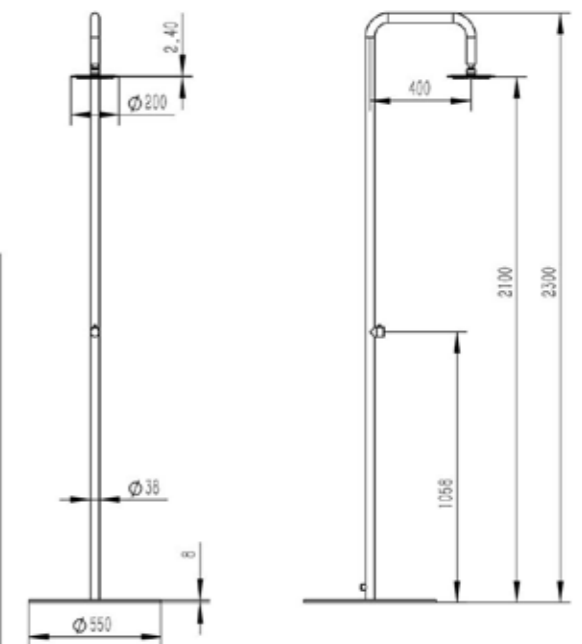



IT

Colonna Doccia In Acciaio Inox Nautico 316l Per Esterno Sined Polifemo. Realizzata Con Temporizzatore Per Massimo Comfort e Risparmio Acqua. Installazione Semplificata e Resistenza Unica Con Scatola C-box Dedicata. Ideale Per Ogni Spazio

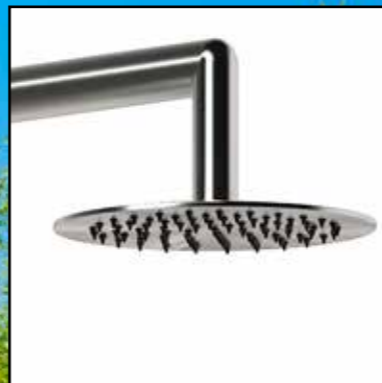

EN

Sined Polifemo Nautical 316l Stainless Steel Outdoor Shower Column. Made With Timer For Maximum Comfort And Water Saving. Simplified Installation and Unique Resistance With Dedicated C-box. Ideal For Any Outdoor Space.

FR

Colonne de douche d'extérieur en acier inoxydable 316l Sined Polifemo. Avec minuterie pour un maximum de confort et d'économie d'eau. Installation simplifiée et résistance unique grâce à une boîte en C dédiée. Idéale pour tout espace extérieur.

DE

Sined Polifemo Nautical 316l Edelstahl Outdoor Dusche Säule. Hergestellt mit Timer für maximalen Komfort und Wassereinsparung. Vereinfachte Installation und einzigartiger Widerstand mit dediziertem C-Kasten. Ideal für jeden Außenbereich.

ES

Sined Polifemo Náutico 316l Acero Inoxidable Columna De Ducha Al Aire Libre. Fabricada Con Temporizador Para Máximo Comfort Y Ahorro De Agua. Instalación Simplificada Y Resistencia Única Con Caja C Dedicada. Ideal Para Cualquier Espacio Al Aire Libre.

DOCCIA-INOX-POLIFEMO

8025431153103

MATERIALE ACCIAIO INOX 316L
MATERIAL 316L STAINLESS

UGELLI ANTICALCARE
ANTISCALE NOZZLES

PESO 17,5 KG
WEIGHT 17,5 KG

GETTO D'ACQUA VERTICALE
WATER JET VERTICAL



**ESCLUSIVO SISTEMA DI FISSA
GIO A PAVIMENTO SUPER-BOX*
ATTACCO ACQUA FREDDA**

MAGGIORI INFORMAZIONI NELLE PRIME
PAGINE

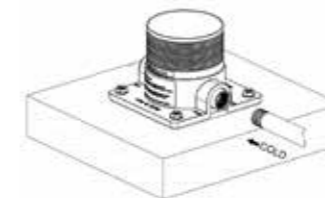

**EXCLUSIVE SUPER-BOX* QUICK
FLOOR ATTACHMENT SYSTEM
DOUBLE HOT/COLD WATER
CONNECTION**

MORE INFORMATION ON THE FIRST PAGES

ACQUA FREDDA
COLD WATER



FUNZIONE TIMER
TIMER FUNCTION



ACCESSORI ACCIAIO INOX 304
ACCESSORIES STAINLESS STEEL 304

**PRODOTTO IN DUE
PARTI. SCATOLA**

FACILE DA MANEGGIARE
PRODUCT IN TWO PARTS
EASY-TO-HANDLE BOX

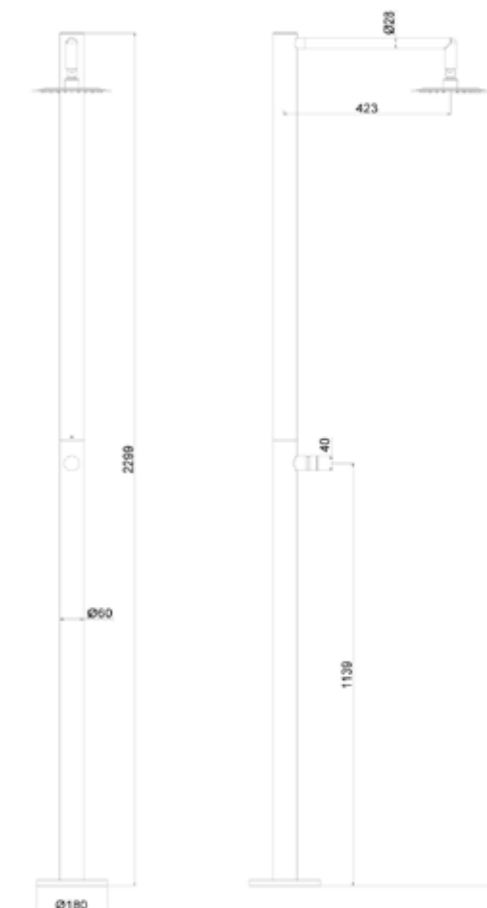

DOCCIA-INOX-ORTRO-2T

8025431153110

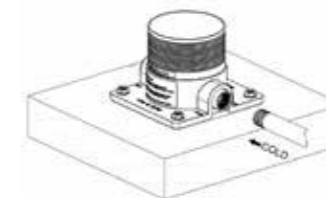
MATERIALE ACCIAIO INOX 316L
MATERIAL 316L STAINLESS**UGELLI ANTICALCARE**
ANTISCALE NOZZLES**PESO 17,5 KG**
WEIGHT 17,5 KG**GETTO D'ACQUA VERTICALE**
WATER JET VERTICAL**ACCESSORI ACCIAIO INOX 304**
ACCESSORIES STAINLESS STEEL 304**PRODOTTO IN DUE**
PARTI. SCATOLA
FACILE DA MANEGGIARE
PRODUCT IN TWO PARTS
EASY-TO-HANDLE BOX**ESCLUSIVO SISTEMA DI FISSA**
GIO A PAVIMENTO SUPER-BOX*
ATTACCO ACQUA FREDDAMAGGIORI INFORMAZIONI NELLE PRIME
PAGINE**EXCLUSIVE SUPER-BOX* QUICK**
FLOOR ATTACHMENT SYSTEM
DOUBLE HOT/COLD WATER
CONNECTION

MORE INFORMATION ON THE FIRST PAGES

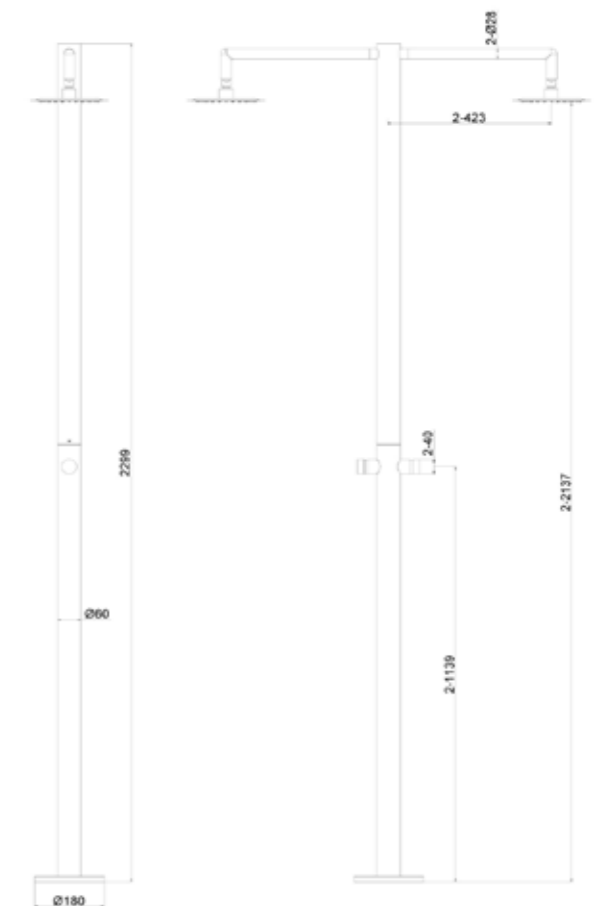
ACQUA FREDDA
COLD WATER**FUNZIONE TIMER**
TIMER FUNCTION**IT**

Doccia Esterna Con Due Soffioni In Acciaio Inox Nautico 316l Sined Orto. Progettata Per Massimo Comfort e Risparmio Di Acqua, Con Installazione Semplificata e Resistenza Unica, Unisce Design Italiano e Innovazione. Ideale Per Ogni Spazio Esterno.

EN

Sined Orto Nautical 316L Stainless Steel Outdoor Shower With Two Showerheads. Designed For Maximum Comfort And Water Savings, With Simplified Installation And Unique Resistance, Combining Italian Design And Innovation. Ideal For Any Outdoor Space.

FR

Douche de tête Sined Orto Nautical en acier inoxydable 316l. Conçue pour un maximum de confort et d'économies d'eau, avec une installation simplifiée et une résistance unique, combinant le design italien et l'innovation. Idéale pour tout espace extérieur.

DE

Sined Orto Nautical 316l Edelstahl-Kopfbrause. Entwickelt für maximalen Komfort und Wassereinsparung, mit vereinfachter Installation und einzigartiger Widerstandsfähigkeit, die italienisches Design und Innovation vereint. Ideal für jeden Außenbereich.

ES

Ducha Superior Sined Orto Nautical 316l Acero Inoxidable. Diseñada Para Máximo Confort Y Ahorro De Agua, Con Instalación Simplificada Y Resistencia Única, Combinando Diseño Italiano E Innovación. Ideal Para Cualquier Espacio Al Aire Libre.

DOCCIA-INOX-CERBERO-3T

8025431153127

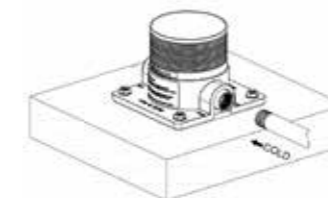
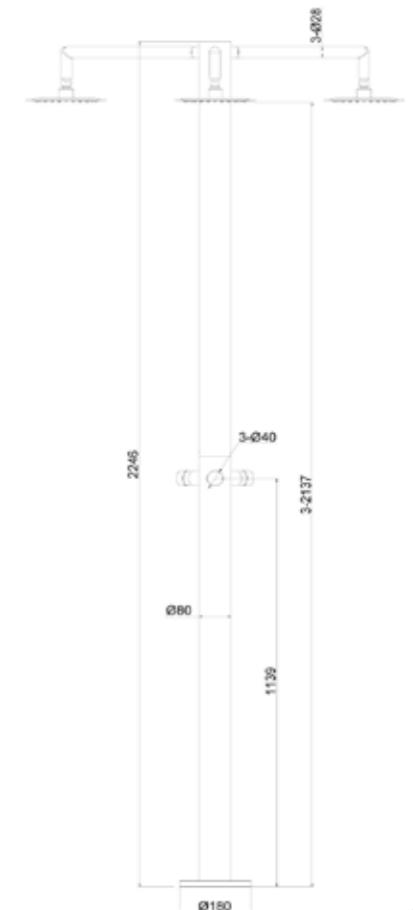
MATERIALE ACCIAIO INOX 316L
MATERIAL 316L STAINLESS**UGELLI ANTICALCARE**
ANTISCALE NOZZLES**PESO 17,5 KG**
WEIGHT 17,5 KG**GETTO D'ACQUA VERTICALE**
WATER JET VERTICAL**ACCESSORI ACCIAIO INOX 304**
ACCESSORIES STAINLESS STEEL 304**PRODOTTO IN DUE**
PARTI. SCATOLA
FACILE DA MANEGGIARE
PRODUCT IN TWO PARTS
EASY-TO-HANDLE BOX**ESCLUSIVO SISTEMA DI FISSA**
GIO A PAVIMENTO SUPER-BOX*
ATTACCO ACQUA FREDDA**MAGGIORI INFORMAZIONI NELLE PRIME**
PAGINE**EXCLUSIVE SUPER-BOX* QUICK**
FLOOR ATTACHMENT SYSTEM
DOUBLE HOT/COLD WATER
CONNECTION**MORE INFORMATION ON THE FIRST PAGES****ACQUA FREDDA**
COLD WATER**FUNZIONE TIMER**
TIMER FUNCTION**IT**

La Doccia Esterna Cerbero Di Sined Unisce Mito e Design: 3 Soffioni Per Uso Collettivo, In Acciaio Inox 316l. Eleganza e Robustezza Per Ogni Ambiente Esterno, Garantendo Funzionalità e Resistenza. Ideale Per Giardini, Piscine, Terme, Spiaggia, Campeggi.

EN

The Cerbero Outdoor Shower by Sined combines Myth and Design: 3 overhead showers for collective use, in 316l stainless steel. Elegance and robustness for any outdoor environment, guaranteeing functionality and resistance. Ideal For Gardens, Pools, Spas,

FR

La douche extérieure Cerbero de Sined allie Mythe et Design : 3 douches de tête à usage collectif, en inox 316l. Élégance et robustesse pour tout environnement extérieur, garantissant fonctionnalité et résistance. Idéale pour les jardins, les piscines, les spas, les plages, les campings.

DE

Die Cerbero Outdoor-Dusche von Sined verbindet Mythos und Design: 3 Kopfbrausen für den gemeinsamen Gebrauch, aus Edelstahl 316l. Eleganz und Robustheit für jeden Außenbereich, die Funktionalität und Widerstandsfähigkeit garantieren. Ideal für

ES

La Ducha de Exterior Cerbero de Sined combina Mito y Diseño: 3 duchas de techo para uso colectivo, en acero inoxidable 316l. Elegancia y robustez para cualquier ambiente exterior, garantizando funcionalidad y resistencia. Ideal para jardines, piscinas, spas,

DOCCIA-INOX-IDRA 4T

8025431153134

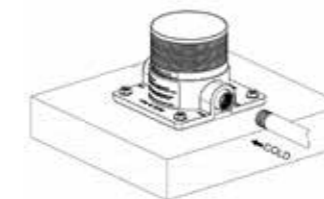
MATERIALE ACCIAIO INOX 316L
MATERIAL 316L STAINLESS**UGELLI ANTICALCARE**
ANTISCALE NOZZLES**PESO 17,5 KG**
WEIGHT 17,5 KG**GETTO D'ACQUA VERTICALE**
WATER JET VERTICAL**ESCLUSIVO SISTEMA DI FISSA**
GIO A PAVIMENTO SUPER-BOX*
ATTACCO ACQUA FREDDAMAGGIORI INFORMAZIONI NELLE PRIME
PAGINE**EXCLUSIVE SUPER-BOX* QUICK**
FLOOR ATTACHMENT SYSTEM
DOUBLE HOT/COLD WATER
CONNECTION

MORE INFORMATION ON THE FIRST PAGES

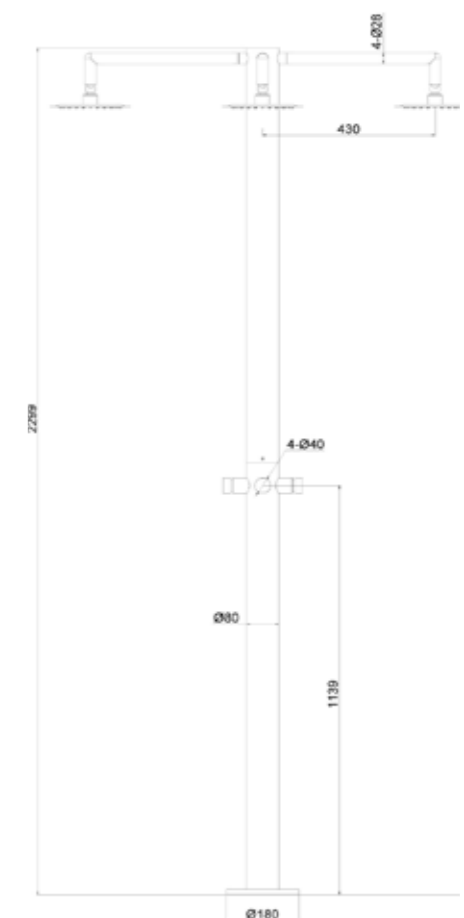
ACQUA FREDDA
COLD WATER**FUNZIONE TIMER**
TIMER FUNCTION**ACCESSORI ACCIAIO INOX 304**
ACCESSORIES STAINLESS STEEL 304**PRODOTTO IN DUE**
PARTI. SCATOLA**FACILE DA MANEGGIARE**
PRODUCT IN TWO PARTS
EASY-TO-HANDLE BOX**IT**

Sined Presenta Idra: La
Doccia Esterna In Acciaio
Inox 316l, Sinonimo Di
Eleganza e Durabilità.
Progettata Per Massimo
Comfort Con Installazione
Semplificata e Resistenza
Unica, Unisce Design
Italiano e Innovazione.
Ideale Per Ogni Spazio
Esterno.

EN

Sined Presents Idra: The
316l Stainless Steel Outdoor
Shower, Synonymous With
Elegance And Durability.
Designed For Maximum
Comfort With Simplified
Installation And Unique
Resistance, It Combines
Italian Design And
Innovation. Ideal For Any
Outdoor Space.

FR

Sined présente Idra : la
douche d'extérieur en
acier inoxydable 316l,
synonyme d'élégance et de
durabilité. Conçue pour un
confort maximal, avec une
installation simplifiée et
une résistance unique, elle
combine le design italien
et l'innovation. Idéale pour
tout espace extérieur.

DE

Sined präsentiert Idra:
Die Außendusche
aus 316l-Edelstahl,
Synonym für Eleganz und
Langlebigkeit. Entworfen
für maximalen Komfort
mit einfacher Installation
und einzigartiger
Widerstandsfähigkeit,
kombiniert sie
italienisches Design und

ES

Sined Presenta Idra:
La Ducha Exterior De
Acero Inoxidable 316l,
Sinónimo De Elegancia
Y Durabilidad. Diseñada
Para Máximo Confort Con
Instalación Simplificada
Y Resistencia Única,
Combina Diseño Italiano
E Innovación. Ideal Para
Cualquier Espacio Al Aire
Libre.

IT

Mini Piantana Acciaio Inossidabile Per Vasche Da Bagno Free Standing Con Doccetta Sined Oristano Inossidabile Miscelazione Sia Del Soffione Che Del Doccino Mobile Doccia Con Ingresso Acqua Calda e Fredda In Acciaio Di Ottima Qualità Inossidabile 316L Adatta Anche Da Esterno 6 cm.

**DOCCIA-ORISTANO-INOX**

8025431018617

MATERIALE ACCIAIO INOX 316L
MATERIAL 316L STAINLESS

UGELLI ANTICALCARE
ANTISCALE NOZZLES

PESO 8,5 KG
WEIGHT 8,5 KG

INCLUDE UNA SACCA
DI PROTEZIONE
INCLUDES A
PROTECTION BAG



ACCESSORI ACCIAIO INOX 304
ACCESSORIES STAINLESS STEEL 304

PRODOTTO IN DUE
PARTI. SCATOLA FACILE DA
MANEGGIARE
PRODUCT IN TWO
PARTS EASY-TO-HANDLE
BOX



ACQUA
CALDA E FREDDA
WATER
HOT AND COLD

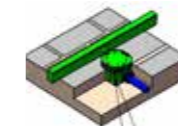
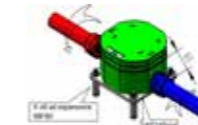

ESCLUSIVO SISTEMA DI
FISSA GIO A PAVIMENTO
C-BOX.
DOPPIO ATTACCO
ACQUA CALDA E
FREDDA.

EXCLUSIVE C-BOX
QUICK FLOOR
ATTACHMENT SYSTEM
DOUBLE HOT/COLD
WATER CONNECTION

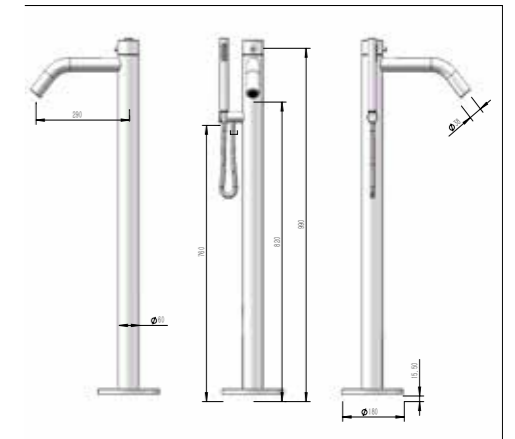
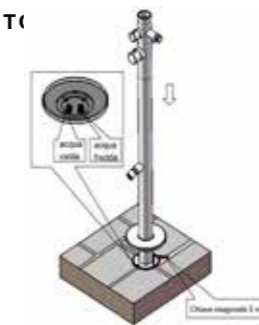
**EN**

Sined Oristano Stainless Steel Mini Freestanding Freestanding Bathtub Stand with Hand Shower Sined Oristano Stainless Steel Shower unit with Hot and Cold Water Inlet in High Quality Stainless Steel 316L Suitable for outdoor use 6 cm.

FR

Sined Oristano Stainless Steel Mini Freestanding Bathtub Stand with Hand Shower Sined Oristano Stainless Steel Shower unit with Hot and Cold Water Inlet in High Quality Stainless Steel 316L Suitable for outdoor use 6 cm.

DE

Sined Oristano Edelstahl-Mini-Badewannenständer mit Handbrause Sined Oristano Edelstahl-Duscheinheit mit Warm- und Kaltwasseranschluss aus hochwertigem Edelstahl 316L Geeignet für den Außenbereich 6 cm.

ES

Sined Oristano Acero Inoxidable Mini Bañera Independiente Soporte con Ducha de Mano Sined Oristano Ducha de Acero Inoxidable con Entrada de Agua Caliente y Fría en Acero Inoxidable de Alta Calidad 316L Apto para uso exterior 6 cm.

DOCCIA-ORISTANO-NERA

8025431150942

MATERIALE ACCIAIO INOX 316L
MATERIAL 316L STAINLESS

UGELLI ANTICALCARE
ANTISCALE NOZZLES

PESO 8,5 KG
WEIGHT 8,5 KG

INCLUDE UNA SACCA
DI PROTEZIONE
INCLUDES A
PROTECTION BAG



ACCESSORI ACCIAIO INOX 304
ACCESSORIES STAINLESS STEEL 304



PRODOTTO IN DUE
PARTI. SCATOLA FACILE DA
MANEGGIARE
PRODUCT IN TWO
PARTS EASY-TO-HANDLE
BOX

ACQUA
CALDA E FREDDA
WATER
HOT AND COLD



IT

Rubinetto Nero a Pavimento Per Vasca Da Bagno Con Doccino Mobile. Colonna Doccia Con Rubinetto Nero Per Vasca Freestanding Sined Doccia Con Ingresso Acqua Calda e Fredda In Acciaio Di Ottima Qualità Inox 316L Adatta Anche Da Esterno Tubo Acciaio Da 6 Cm.

EN

Freestanding Black Bathtub Faucet With Hand Shower. Shower Column With Black Faucet For Freestanding Bathtub Sined Shower With Hot And Cold Water Inlet In High Quality 316L Stainless Steel Also Suitable For Outdoor Use 6cm Steel Pipe.

FR

Robinet de baignoire noir autoportant avec douchette. Colonne de Douche avec Robinet Noir pour Baignoire Autoportante Douche Doublée avec Entrée d'Eau Chaude et Froide en Acier Inoxydable 316L de Haute Qualité Egalement Adapté à l'Utilisation en Extérieur Tuyau en Acier de 6cm.

DE

Freistehende schwarze Badewannenarmatur mit Handbrause. Duschsäule für freistehende Badewanne Sined Dusche mit heißem und kaltem Wasser Einlass in hoher Qualität 316L Edelstahl auch geeignet für den Außenbereich 6cm Stahlrohr.

ES

Grifo De Bañera Independiente Negro Con Ducha De Mano. Columna de ducha con grifo negro para bañera independiente Sined ducha con entrada de agua caliente y fría en acero inoxidable 316L de alta calidad también es adecuado para uso al aire libre 6cm tubo de acero.

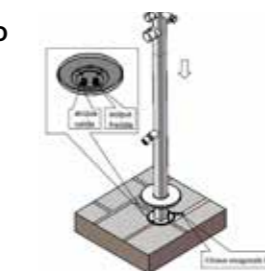
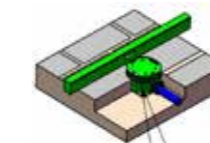
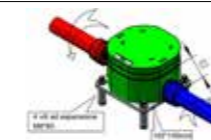

ESCLUSIVO SISTEMA DI
FISSA GIO A PAVIMENTO
C-BOX.
DOPPIO ATTACCO
ACQUA CALDA E
FREDDA.
EXCLUSIVE C-BOX
QUICK FLOOR
ATTACHMENT SYSTEM
DOUBLE HOT/COLD
WATER CONNECTION

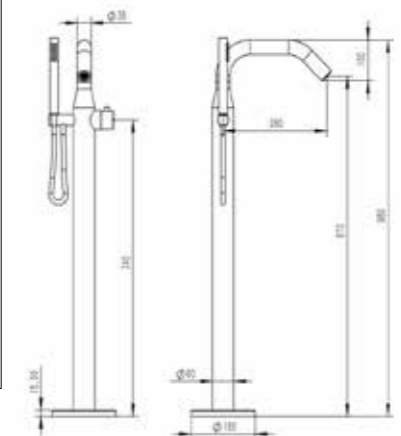

LUNA-INOX

DUE MODI PER COLLEGARE L'ACQUA: LATERALE O INFERIORE

Uno degli aspetti più tecnici e innovativi del modello LUNA è il sistema di ingressi acqua. La separazione tra l'ingresso dell'acqua calda e quella fredda non è solo una caratteristica di comfort, ma anche un requisito tecnico importante che migliora l'efficienza e la sicurezza dell'uso: Ingressi Acqua Separati: Il controllo indipendente delle temperature permette agli utenti di personalizzare l'esperienza della doccia in base alle proprie preferenze personali o alle condizioni meteorologiche. In ambienti più freddi, l'acqua calda può essere miscelata precisamente per un comfort ottimale, mentre in giorni più caldi, l'acqua fredda può essere utilizzata esclusivamente per un rinfrescante sollievo.

Possibilità di Ingressi Lateralmente e Inferiormente: La versatilità nella scelta del posizionamento degli ingressi dell'acqua permette agli installatori di adattare la doccia a diverse configurazioni spaziali. Che si tratti di una predisposizione già esistente o di una nuova costruzione, il modello LUNA può essere integrato con facilità. L'opzione degli ingressi inferiori è particolarmente utile per installazioni a filo pavimento, mantenendo le linee pulite e minimaliste, mentre gli ingressi laterali sono ideali per strutture esistenti dove le connessioni possono essere facilmente mascherate o integrate.

TWO WAYS TO CONNECT THE WATER: SIDE OR BOTTOM

One of the most technical and innovative aspects of the LUNA model is the water inlet system. Separating the hot and cold water inlets is not only a comfort feature, but also an important technical requirement that improves efficiency and safety in use: Separate Water Inlets: Independent temperature control allows users to customise the shower experience according to personal preferences or weather conditions. On colder days, hot water can be mixed precisely for optimal comfort, while on hotter days, cold water can be used exclusively for refreshing relief. Possibility of side and bottom inputs: The versatility in choosing the positioning of the water inlets allows installers to adapt the shower to different spatial configurations. Whether it is an existing layout or a new construction, the LUNA model can be easily integrated. The lower inlets option is particularly useful for flush floor installations, maintaining clean, minimalist lines, while the side inlets are ideal for existing structures where connections can be easily masked or integrated.



SINED IN ESCLUSIVA MONDIALE!
DOPPIO INGRESSO ACQUA
LATERALE O INFERIORE

SINED WORLD WIDE EXCLUSIVE!
DOUBLE WATER INLET
SIDE OR BOTTOM

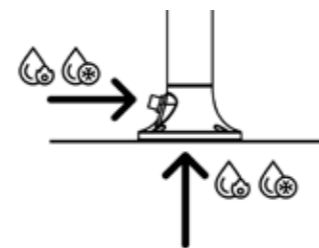

**IT**

Esplora l'eccellenza della Doccia In Acciaio Inox Nautico 316L Sined Inox Luna D Inox, ideale per interni ed esterni. Resistente, elegante e progettata per durare, questa doccia unisce funzionalità e stile per un comfort superiore in ogni ambiente.

EN

Explore the excellence of the Sined Inox 316L Luna D Stainless Steel Shower, ideal for indoor and outdoor use. Durable, elegant and designed to last, this shower combines functionality and style for superior comfort in any environment.

FR

Découvrez l'excellence de la douche en acier inoxydable Sined Inox 316L Luna D, idéale pour l'intérieur et l'extérieur. Durable, élégante et conçue pour durer, cette douche allie fonctionnalité et style pour un confort supérieur dans n'importe quel environnement.

DE

Entdecken Sie die Vorzüge der Sined Inox 316L Luna D Edelstahl-Dusche, die ideal für den Innen- und Außenbereich geeignet ist. Langlebig, elegant und auf Langlebigkeit ausgelegt, kombiniert diese Dusche Funktionalität und Stil für höchsten Komfort in jeder Umgebung.

ES

Explore la excelencia de la ducha de acero inoxidable Sined Inox 316L Luna D, ideal para interiores y exteriores. Duradera, elegante y diseñada para durar, esta ducha combina funcionalidad y estilo para ofrecer un confort superior en cualquier entorno.

DOCCIA-INOX-LUNA-D-INOX

8025431153141

MATERIALE ACCIAIO INOX 316L
MATERIAL 316L STAINLESS

UGELLI ANTICALCARE
ANTISCALE NOZZLES

PESO KG
WEIGHT KG

INCLUDE UNA SACCA
DI PROTEZIONE
INCLUDES A PROTEC-
TION BAG



ESCLUSIVA MONDIALE!

DOPPIO INGRESSO ACQUA
LATERALE O INFERIORE

WORLD EXCLUSIVE!

DOUBLE WATER INLET
SIDE OR BOTTOM

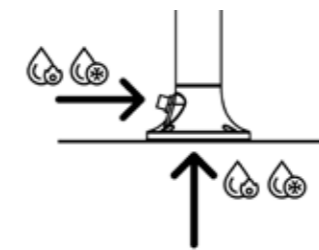

ACQUA
CALDA E FREDDA
WATER
HOT AND COLD



GETTO D'ACQUA
VERTICALE
WATER JET
VERTICAL



ACCESSORI ACCIAIO INOX 304
ACCESSORIES STAINLESS STEEL 304

DUE FILTRI ANTICALCARE INCLUSI
TWO ANTI-SCALE FILTERS INCLUDED

FILTRO ANTICALCARE INCLUSO
FILTER LIMESCALE INCLUDED



PRODOTTO IN DUE
PARTI. SCATOLA FAC-
ILE DA MANEGGIARE
PRODUCT IN TWO-
PARTS EASY-TO-HAN-
DLE BOX

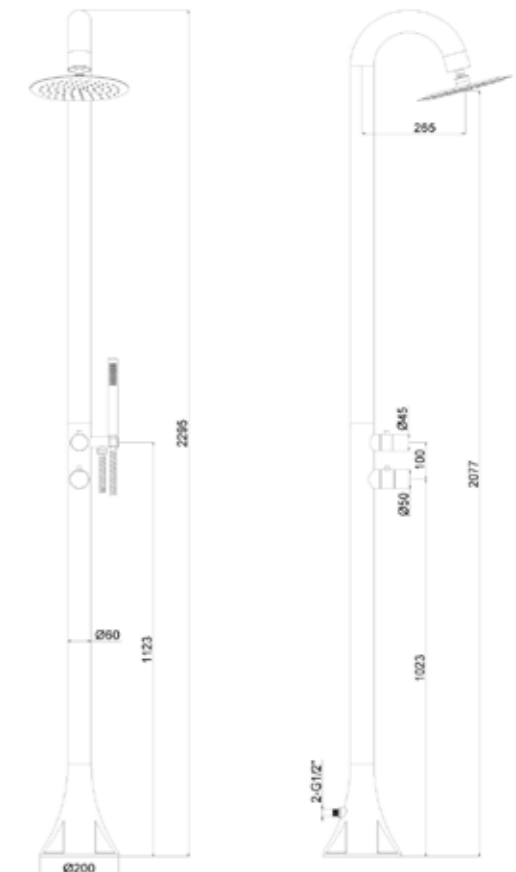

**IT**

La doccia modello LUNA D NERA in Alluminio Aisi Inox 316L combina design e funzionalità. Con ingressi per acqua calda e fredda, ideale per installazioni esterne. La colonna in inox nero assicura anche una lunga durata grazie all'alta qualità dell'acciaio.

EN

The shower model LUNA D NERA in Aluminium Aisi Inox 316L combines design and functionality. With hot and cold water inlets, it is ideal for outdoor installation. The black stainless steel column also ensures a long service life thanks to the high quality steel.

FR

Le modèle de douche LUNA D NERA en Aluminium Aisi Inox 316L allie design et fonctionnalité. Dotée de prises d'eau chaude et froide, elle est idéale pour une installation à l'extérieur. La colonne en acier inoxydable noir garantit également une longue durée de vie grâce à la qualité de l'acier.

DE

Das Duschmodell LUNA D NERA aus Aluminium Aisi Inox 316L verbindet Design und Funktionalität. Mit Warm- und Kaltwasserzulauf ist es ideal für die Installation im Freien. Die schwarze Edelstahlsäule gewährleistet dank des hochwertigen Stahls zudem

ES

El modelo de ducha LUNA D NERA en Aluminio Aisi Inox 316L combina diseño y funcionalidad. Con entradas de agua fría y caliente, es ideal para su instalación en exteriores. Además, la columna de acero inoxidable negro garantiza una larga vida útil gracias al acero de alta calidad.

DOCCIA-INOX-LUNA-D-NERA

8025431153172

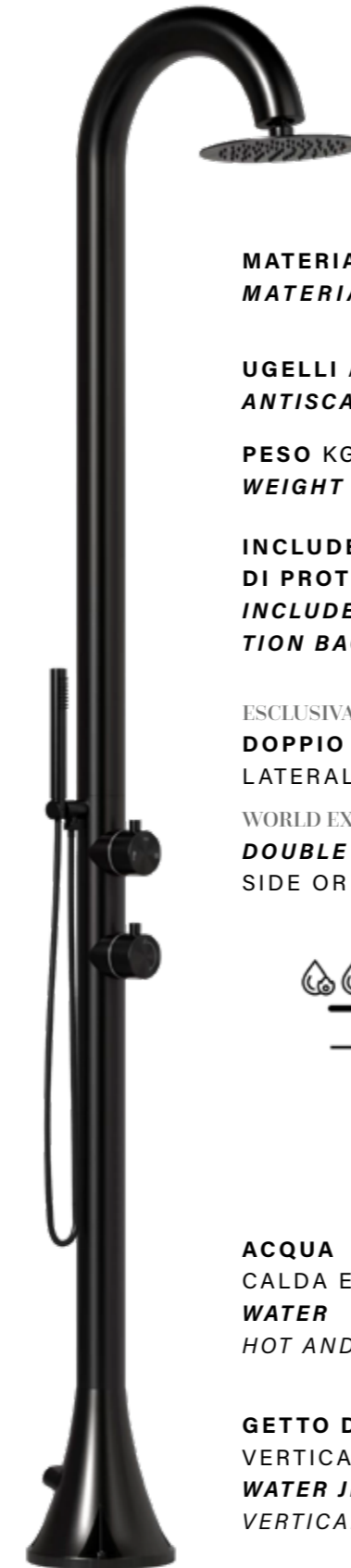

MATERIALE ACCIAIO INOX 316L
MATERIAL 316L STAINLESS

UGELLI ANTICALCARE
ANTISCALE NOZZLES

PESO KG
WEIGHT KG

INCLUDE UNA SACCA
DI PROTEZIONE
INCLUDES A PROTEC-
TION BAG



ESCLUSIVA MONDIALE!
DOPPIO INGRESSO ACQUA
LATERALE O INFERIORE

WORLD EXCLUSIVE!
DOUBLE WATER INLET
SIDE OR BOTTOM

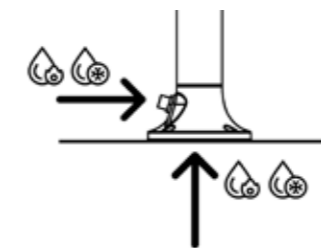

ACQUA
CALDA E FREDDA
WATER
HOT AND COLD



GETTO D'ACQUA
VERTICALE
WATER JET
VERTICAL



ACCESSORI ACCIAIO INOX 304
ACCESSORIES STAINLESS STEEL 304

DUE FILTRI ANTICALCARE INCLUSI
TWO ANTI-SCALE FILTERS INCLUDED

FILTRO ANTICALCARE INCLUSO
FILTER LIMESCALE INCLUDED



PRODOTTO IN DUE
PARTI. SCATOLA FAC-
ILE DA MANEGGIARE
PRODUCT IN TWO-
PARTS EASY-TO-HAN-
DLE BOX

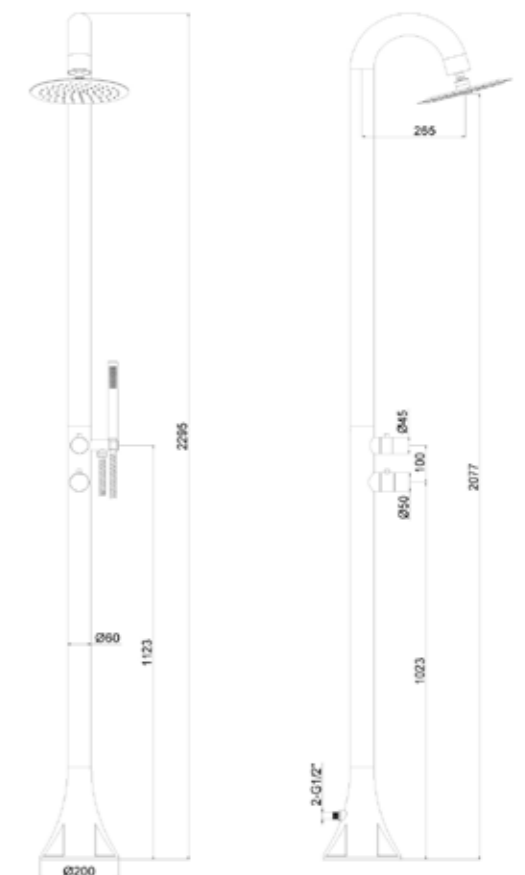

DOCCIA-INOX-LUNA-D-BIANCA

8025431153196

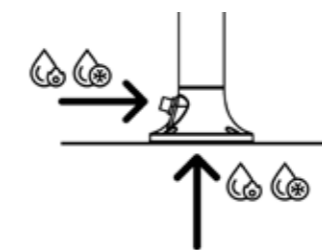
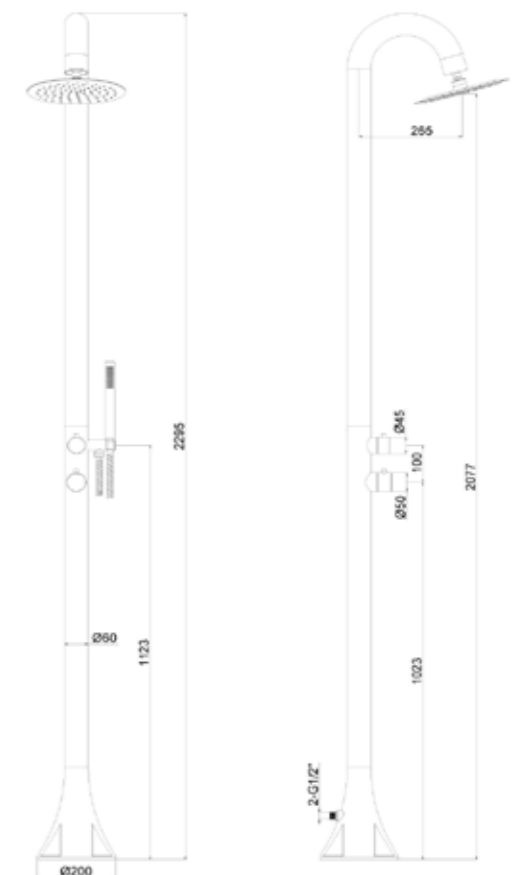
MATERIALE ACCIAIO INOX 316L
MATERIAL 316L STAINLESS**UGELLI ANTICALCARE**
ANTISCALE NOZZLES**PESO KG**
WEIGHT KG**INCLUDE UNA SACCA**
DI PROTEZIONE
INCLUDES A PROTEC-
TION BAG**ESCLUSIVA MONDIALE!**
DOPPIO INGRESSO ACQUA
LATERALE O INFERIORE**WORLD EXCLUSIVE!**
DOUBLE WATER INLET
SIDE OR BOTTOM**ACQUA**
CALDA E FREDDA
WATER
HOT AND COLD**GETTO D'ACQUA**
VERTICALE
WATER JET
VERTICAL**ACCESSORI ACCIAIO INOX 304**
ACCESSORIES STAINLESS STEEL 304**DUE FILTRI ANTICALCARE INCLUSI**
TWO ANTI-SCALE FILTERS INCLUDED**FILTRO ANTICALCARE INCLUSO**
FILTER LIMESCALE INCLUDED**PRODOTTO IN DUE**
PARTI. SCATOLA FAC-
ILE DA MANEGGIARE
PRODUCT IN TWO-
PARTS EASY-TO-HAN-
DLE BOX**IT**

La Doccia INOX LUNA D BIANCA, dotata di doccino mobile e realizzata in elegante acciaio inox nautico, è perfettamente adattabile sia a spazi interni che esterni. Progettata per gestire grandi carichi di lavoro, unisce funzionalità resistenza e stile.

EN

The LUNA D BIANCA INOX Shower, equipped with a movable hand shower and made of elegant nautical stainless steel, is perfectly suited to both indoor and outdoor spaces. Designed to handle large workloads, it combines functionality strength and style.

FR

La douche LUNA D BIANCA INOX, équipée d'une douchette mobile et réalisée dans un élégant acier inoxydable nautique, est parfaitement adaptée aux espaces intérieurs et extérieurs. Conçue pour supporter de grandes charges de travail, elle allie fonctionnalité, force et style.

DE

Die LUNA D BIANCA INOX Dusche, ausgestattet mit einer beweglichen Handbrause und aus elegantem, nautischem Edelstahl, eignet sich perfekt für Innen- und Außenbereiche. Entwickelt, um große Arbeitslasten zu bewältigen, kombiniert sie Funktionalität, Stärke und

ES

La ducha LUNA D BIANCA INOX, equipada con una teleducha móvil y fabricada en elegante acero inoxidable náutico, se adapta perfectamente tanto a espacios interiores como exteriores. Diseñada para soportar grandes cargas de trabajo, combina funcionalidad fuerza y estilo.

DOCCIA-INOX-LUNA-D-ORO

8025431153189

MATERIALE ACCIAIO INOX 316L
MATERIAL 316L STAINLESS

UGELLI ANTICALCARE
ANTISCALE NOZZLES

PESO KG
WEIGHT KG

INCLUDE UNA SACCA
DI PROTEZIONE
INCLUDES A PROTEC-
TION BAG



ESCLUSIVA MONDIALE!
DOPIO INGRESSO ACQUA
LATERALE O INFERIORE

WORLD EXCLUSIVE!
DOUBLE WATER INLET
SIDE OR BOTTOM

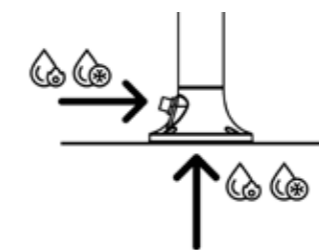

ACQUA
CALDA E FREDDA
WATER
HOT AND COLD



GETTO D'ACQUA
VERTICALE
WATER JET
VERTICAL



ACCESSORI ACCIAIO INOX 304
ACCESSORIES STAINLESS STEEL 304

DUE FILTRI ANTICALCARE INCLUSI
TWO ANTI-SCALE FILTERS INCLUDED

FILTRO ANTICALCARE INCLUSO
FILTER LIMESCALE INCLUDED



PRODOTTO IN DUE
PARTI. SCATOLA FAC-
ILE DA MANEGGIARE
PRODUCT IN TWO-
PARTS EASY-TO-HAN-
DLE BOX

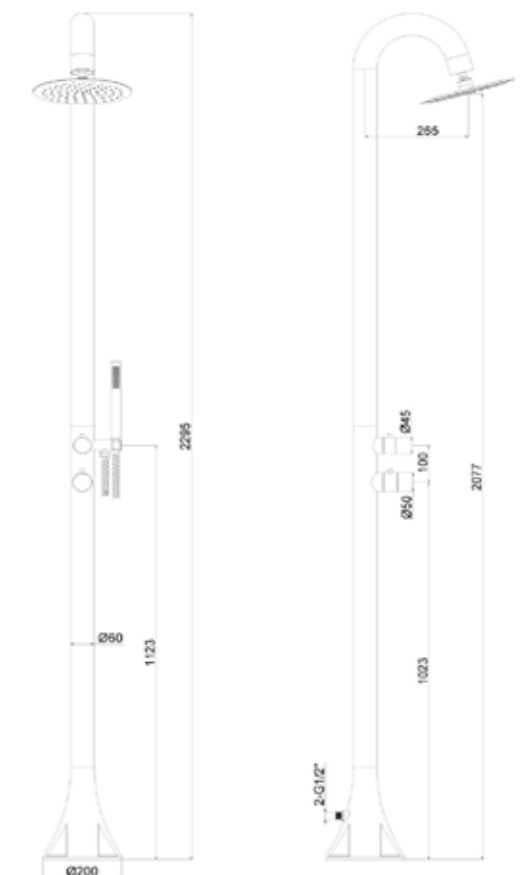

IT

Doccia In Acciaio Inox Nautico 316l Sined Inox Luna colore Oro. Ingressi per acqua calda e fredda, ideale per installazioni esterne o per il bagno di casa. La colonna in inox assicura anche una lunga durata grazie all'alta qualità dell'acciaio.

EN

Sined Inox 316l Stainless Steel Shower Luna colour Gold. Inlets for hot and cold water, ideal for outdoor installations or the bathroom at home. The stainless steel column also ensures a long service life thanks to the high quality steel.

FR

Luna de douche en acier inoxydable Sined Inox 316l couleur or. Entrées pour l'eau chaude et l'eau froide, idéales pour les installations extérieures ou la salle de bains à la maison. La colonne en acier inoxydable garantit également une longue durée de vie grâce à la qualité de l'acier.

DE

Sined Inox 316l Edelstahl Dusche Luna Farbe Gold. Eingänge für warmes und kaltes Wasser, ideal für Außenanlagen oder das Badezimmer zu Hause. Die Edelstahlsäule sorgt auch für eine lange Lebensdauer dank der hohen Qualität des Stahls.

ES

Sined Inox 316l Acero Inoxidable Ducha Luna color Oro. Entradas para agua caliente y fría, ideal para instalaciones exteriores o el cuarto de baño de casa. La columna de acero inoxidable también garantiza una larga vida útil gracias al acero de alta calidad.

**IT**

La doccia modello LUNA D ORO ROSA in Alluminio Aisi Inox 316L nautico, combina design e funzionalità. Realizzata in raffinato oro rosa con doccino mobile e ingressi per acqua calda e fredda, è ideale per installazioni esterne e interne.

EN

The LUNA D ORO ROSA model shower in nautical 316L Aisi Inox Aluminium combines design and functionality. Made of refined rose gold with movable hand shower and hot and cold water inlets, it is ideal for outdoor and indoor installations.

FR

Le modèle de douche LUNA D ORO ROSA en aluminium 316L Aisi Inox nautique allie design et fonctionnalité. Réalisée en or rose raffiné avec douchette mobile et entrées d'eau chaude et froide, elle est idéale pour les installations à l'extérieur et à l'intérieur.

DE

Das Duschmodell LUNA D ORO ROSA aus nautischem 316L Aisi Inox Aluminium vereint Design und Funktionalität. Sie ist aus veredeltem Roségold mit beweglicher Handbrause und Warm- und Kaltwassereinfläufen gefertigt und eignet sich ideal für Installationen im

ES

La ducha modelo LUNA D ORO ROSA de aluminio Aisi Inox 316L combina diseño y funcionalidad. Fabricada en refinado oro rosa con teleducha móvil y tomas de agua fría y caliente, es ideal para instalaciones exteriores e interiores.

DOCCIA-INOX-LUNA-D-ORO-ROSA

8025431153202

MATERIALE ACCIAIO INOX 316L
MATERIAL 316L STAINLESS

UGELLI ANTICALCARE
ANTISCALE NOZZLES

PESO KG
WEIGHT KG

INCLUDE UNA SACCA
DI PROTEZIONE
INCLUDES A PROTEC-
TION BAG



ESCLUSIVA MONDIALE!
DOPPIO INGRESSO ACQUA
LATERALE O INFERIORE

WORLD EXCLUSIVE!
DOUBLE WATER INLET
SIDE OR BOTTOM

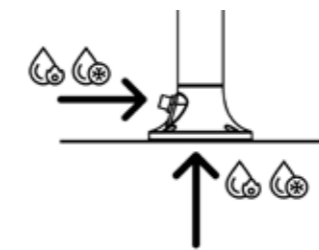

ACQUA
CALDA E FREDDA
WATER
HOT AND COLD



GETTO D'ACQUA
VERTICALE
WATER JET
VERTICAL



ACCESSORI ACCIAIO INOX 304
ACCESSORIES STAINLESS STEEL 304

DUE FILTRI ANTICALCARE INCLUSI
TWO ANTI-SCALE FILTERS INCLUDED

FILTRO ANTICALCARE INCLUSO
FILTER LIMESCALE INCLUDED



PRODOTTO IN DUE
PARTI. SCATOLA FAC-
ILE DA MANEGGIARE
PRODUCT IN TWO-
PARTS EASY-TO-HAN-
DLE BOX

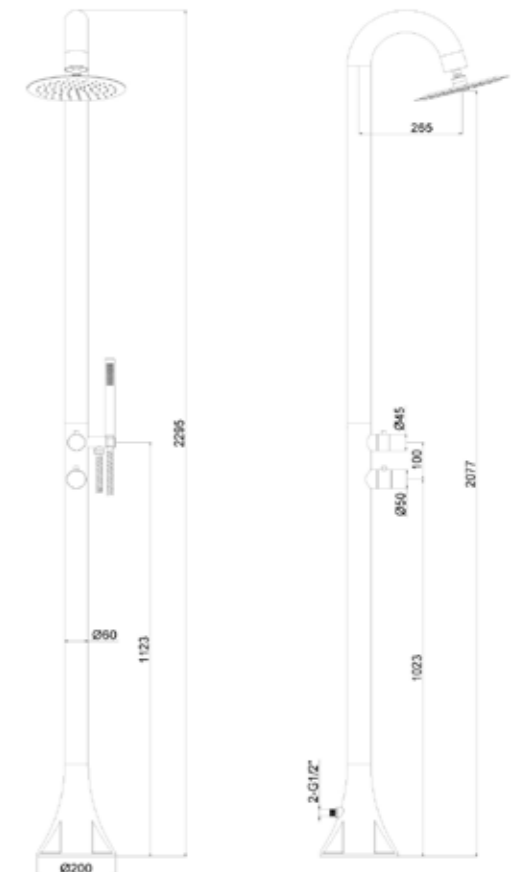



IT

Comfort All'aperto Con La Doccia In Acciaio Inox Nautico Luna, Ideale Per Esterni. Per Giardini o Aree Piscina, Offre Un Getto Di Acqua Fredda Rinfrescante, Resistente Alla Corrosione e Agli Agenti Atmosferici. Durata Eleganza e Stile Senza Tempo.

EN

Outdoor Comfort with the Stainless Steel Shower Nautico Luna, Ideal for Outdoors. For Gardens or Pool Areas, it offers a refreshing, Corrosion and Weather Resistant Cold Water Jet. Durability Timeless Elegance and Style.

FR

Confort extérieur avec la douche en acier inoxydable Nautico Luna, idéale pour l'extérieur. Pour les jardins ou les piscines, elle offre un jet d'eau froide rafraîchissant, résistant à la corrosion et aux intempéries. Durabilité Éléance et style intemporels.

DE

Komfort im Freien mit der Edelstahldusche Nautico Luna, ideal für den Außenbereich. Für Gärten oder Poolbereiche bietet sie einen erfrischenden, korrosions- und witterungsbeständigen Kaltwasserstrahl. Langlebigkeit, zeitlose Eleganz und Stil.

ES

Comodidad al Aire Libre Con la Ducha de Acero Inoxidable Nautico Luna, Ideal Para Exteriores. Para Jardines o Zonas de Piscina, Ofrece un Chorro de Agua Fría Refrescante, Resistente a la Corrosión y a la Intemperie. Durabilidad Elegancia y Estilo Intemporales.

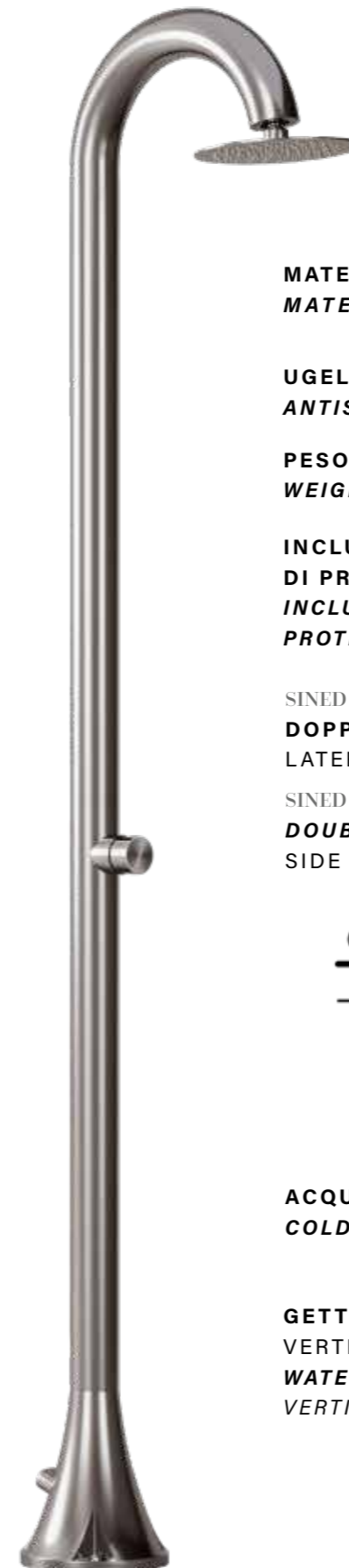

DOCCIA-INOX-LUNA-TMP-INOX

8025431153158

MATERIALE ACCIAIO INOX 316L
MATERIAL 316L STAINLESS

UGELLI ANTICALCARE
ANTISCALE NOZZLES

PESO KG
WEIGHT KG

INCLUDE UNA SACCA
DI PROTEZIONE
INCLUDES A
PROTECTION BAG



SINED IN ESCLUSIVA MONDIALE!
DOPPIO INGRESSO ACQUA
LATERALE O INFERIORE

SINED WORLD WIDE EXCLUSIVE!
DOUBLE WATER INLET
SIDE OR BOTTOM

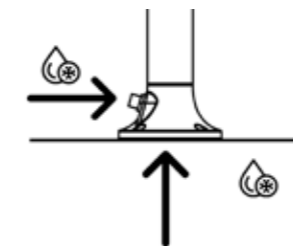

ACQUA FREDDA
COLD WATER



GETTO D'ACQUA
VERTICALE
WATER JET
VERTICAL



ACCESSORI ACCIAIO INOX 304
ACCESSORIES STAINLESS STEEL 304



PRODOTTO IN DUE
PARTI. SCATOLA FACILE
DA MANEGGIARE
PRODUCT IN TWO
PARTS EASY-TO-HANDLE
BOX



FUNZIONE TIMER
TIMER FUNCTION



DOCCIA-INOX-LUNA-TMP-NERA

8025431153165

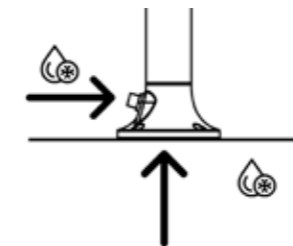
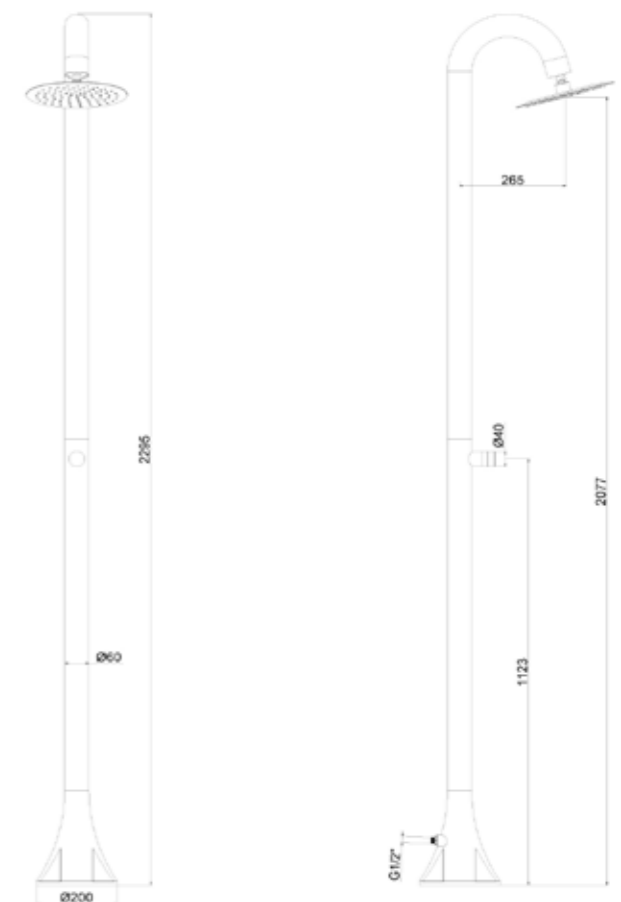
MATERIALE ACCIAIO INOX 316L
MATERIAL 316L STAINLESS**UGELLI ANTICALCARE**
ANTISCALE NOZZLES**PESO KG**
WEIGHT KG**INCLUDE UNA SACCA**
DI PROTEZIONE
INCLUDES A
PROTECTION BAG**SINED IN ESCLUSIVA MONDIALE!**
DOPPIO INGRESSO ACQUA
LATERALE O INFERIORE**SINED WORLD WIDE EXCLUSIVE!**
DOUBLE WATER INLET
SIDE OR BOTTOM**ACQUA FREDDA**
COLD WATER**GETTO D'ACQUA**
VERTICALE
WATER JET
VERTICAL**ACCESSORI ACCIAIO INOX 304**
ACCESSORIES STAINLESS STEEL 304**PRODOTTO IN DUE**
PARTI. SCATOLA FACILE DA
MANEGGIARE
PRODUCT IN TWO
PARTS EASY-TO-HANDLE
BOX**FUNZIONE TIMER**
TIMER FUNCTION**IT**

Nuova Doccia In Acciaio Inox Nautico Luna Di Colore Nero, Ideale Per Esterni. Per Giardini o Aree Piscina, Offre Un Getto Di Acqua Fredda Rinfrescante, Resistente Alla Corrosione e Agli Agenti Atmosferici. Durata, Eleganza e Design Italiano Senza Tempo.

EN

New Black Luna Stainless Steel Shower, Ideal For Outdoors. For Gardens or Pool Areas, it offers a refreshing, Corrosion and Weather Resistant Cold Water Jet. Durability, Elegance and Timeless Italian Design.

FR

Nouvelle douche Black Luna en acier inoxydable, idéale pour l'extérieur. Pour les jardins ou les piscines, elle offre un jet d'eau froide rafraîchissant, résistant à la corrosion et aux intempéries. Durabilité, élégance et design italien intemporel.

DE

Neue schwarze Luna-Edelstahldusche, ideal für den Außenbereich. Für Gärten oder Poolbereiche bietet sie einen erfrischenden, korrosions- und witterungsbeständigen Kaltwasserstrahl. Langlebigkeit, Eleganz und zeitloses italienisches Design.

ES

Nueva Ducha de Acero Inoxidable Luna Negra, Ideal para Exteriores. Para Jardines o Zonas de Piscina, ofrece un refrescante Chorro de Agua Fría Resistente a la Corrosión y a la Intemperie. Durabilidad, Elegancia y Diseño Italiano atemporal.

DOCCE A PARETE

WALL SHOWERS

Scoprite le nostre docce a parete per esterni in acciaio inox 316L, progettate per resistere alle condizioni più estreme e mantenere la loro eleganza nel tempo. Queste docce combinano una durata eccezionale con un design moderno e minimalista, perfetto per qualsiasi spazio esterno. L'installazione a parete ottimizza lo spazio e aggiunge un tocco di lusso e funzionalità al vostro giardino o patio. Ideale per chi cerca qualità e stile superiori in ogni dettaglio.

La doccia esterna a muro SINED è una novità assoluta, progettata per essere fissata con tre punti a parete. Realizzata in acciaio inox AISI 316L (acciaio marino), è ideale per spazi ridotti, attività all'aperto e bagni interni.

Progettata per resistere a grandi carichi di lavoro, offre una soluzione di alta qualità per ogni esigenza.

Materiale: Acciaio Satinato AISI 316L con fusto di 60 mm di diametro.
Ingresso Doppio: Per acqua calda e fredda.

Miscelatore: Cartuccia a 3 vie per controllo della temperatura dall'acqua del soffione e dalla doccetta a mano. per ambienti salini e riducenti. Non necessita di essere posizionata sotto i raggi diretti del sole come le docce solari.

La cura del design e l'attenzione ai dettagli rendono queste docce uniche e apprezzate a livello internazionale. Anche se la produzione è industriale, ogni prodotto nasce da uno studio italiano e viene realizzato sotto strette direttive di controllo qualità in Italia.

Discover our 316L stainless steel outdoor wall showers, designed to withstand the most extreme conditions and retain their elegance over time. These showers combine exceptional durability with a modern, minimalist design, perfect for any outdoor space. The wall-mounted installation optimises space and adds a touch of luxury and functionality to your garden or patio. Ideal for those seeking superior quality and style in every detail.

The SINED wall-mounted outdoor shower is an absolute novelty, designed to be fixed with three points to the wall. Made of AISI 316L stainless steel (marine steel), it is ideal for small spaces, outdoor activities and indoor bathrooms. Designed to withstand large loads, it offers a high quality solution for every need.

Material: Satin stainless steel AISI 316L with 60 mm diameter drum. Double inlet: For hot and cold water. Mixer: 3-way cartridge for temperature control from overhead and hand shower water. for saline and reducing environments. Does not need to be placed in direct sunlight like solar showers.

Careful design and attention to detail make these showers unique and internationally appreciated. Although the production is industrial, each product originates from an Italian studio and is manufactured under strict quality control guidelines in Italy.



DOCCIA-CABRAS-INOX

8025431153080

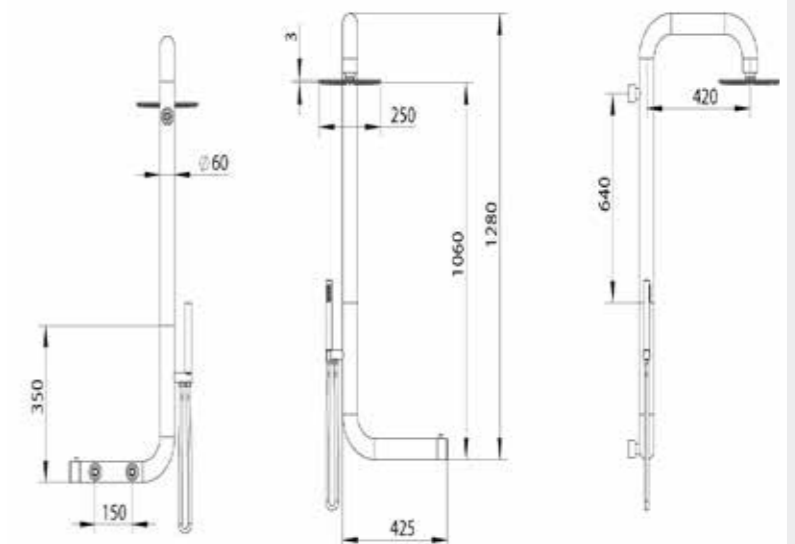
MATERIALE ACCIAIO INOX 316L
MATERIAL 316L STAINLESS**ACCESSORI ACCIAIO INOX 304**
ACCESSORIES STAINLESS STEEL 304**UGELLI ANTICALCARE**
ANTISCALE NOZZLES**PRODOTTO IN DUE**
PARTI. SCATOLA FACILE DA
MANEGGIARE
PRODUCT IN TWO
PARTS EASY-TO-HANDLE
BOX**PESO 8 KG**
WEIGHT 8 KG**INCLUDE UNA SACCA**
DI PROTEZIONE
INCLUDES A
PROTECTION BAG**ACQUA**
CALDA E FREDDA
WATER
HOT AND COLD**GETTO D'ACQUA**
VERTICALE
WATER JET
VERTICAL**IT**

Sined Cabras, Doccia a Parete In Acciaio Inox Aisi 316l, Omaggio Alla Sardegna. Eleganza, Design Avanzato Con Miscelatore e Ampio Soffione. Facile Installazione Con 3 Punti Di Fissaggio, Perfetta Per Spazi Ristretti e Uso Intensivo, Interni o Esterni.

EN

Sined Cabras, Wall Shower In Stainless Steel Aisi 316l, Homage To Sardinia. Elegance, Advanced Design With Mixer and Large Shower Head. Easy Installation With 3 Fixing Points, Perfect For Confined Spaces And Intensive Use, Indoor Or Outdoor.

FR

Sined Cabras, Douche murale en acier inoxydable Aisi 316l, hommage à la Sardaigne. Élégance, design avancé avec mitigeur et large pommeau de douche. Installation facile avec 3 points de fixation, parfaite pour les espaces confinés et les utilisations intensives, à l'intérieur comme à l'extérieur.

DE

Sined Cabras, Wanddusche aus Edelstahl Aisi 316l, eine Hommage an Sardinien. Eleganz, fortschrittliches Design mit Mischer und großem Duschkopf. Einfache Installation mit 3 Befestigungspunkten, perfekt für begrenzte Räume und intensive Nutzung, innen oder außen.

ES

Sined Cabras, Ducha De Pared En Acero Inoxidable Aisi 316l, Homenaje A Cerdeña. Elegancia, Diseño Avanzado Con Mezclador Y Ducha De Gran Tamaño. Fácil Instalación Con 3 Puntos De Fijación, Perfecta Para Espacios Reducidos Y Uso Intensivo, en Interiores o Exteriores.

DOCCIA-CABRAS-NERA

8025431153097

MATERIALE ACCIAIO INOX 316L
MATERIAL 316L STAINLESS**ACCESSORI ACCIAIO INOX 304**
ACCESSORIES STAINLESS STEEL 304**UGELLI ANTICALCARE**
ANTISCALE NOZZLES
PESO 8 KG
WEIGHT 8 KG**PRODOTTO IN DUE**
PARTI. SCATOLA FACILE DA
MANEGGIARE
PRODUCT IN TWO
PARTS EASY-TO-HANDLE
BOX**INCLUDE UNA SACCA**
DI PROTEZIONE
INCLUDES A
PROTECTION BAG**ACQUA**
CALDA E FREDDA
WATER
HOT AND COLD**GETTO D'ACQUA**
VERTICALE
WATER JET
VERTICAL**IT**

Sined Cabras, Doccia Nera a Parete In Acciaio Inox Aisi 316l Nautico, Omaggio Alla Sardegna. Eleganza, Design Avanzato Con Miselatore e Ampio Soffione. Facile Installazione Con 3 Punti Di Fissaggio, Per Spazi Piccoli e Uso Intensivo, Interni o Esterni.

EN

Sined Cabras, Black Wall Shower In Stainless Steel Aisi 316l Nautical, Homage To Sardinia. Elegance, Advanced Design With Mixer And Large Shower Head. Easy Installation With 3 Fastening Points, For Small Spaces And Intensive Use, Indoor Or Outdoor.

FR

Sined Cabras, Douche Murale Noire En Acier Inoxydable Aisi 316l Nautisme, Hommage à La Sardaigne. Élégance, Design Avancé Avec Mitigeur Et Large Pommeau De Douche. Installation Facile Avec 3 Points De Fixation, Pour Les Petits Espaces Et Les Utilisations

DE

Sined Cabras, Schwarze Wanddusche aus Edelstahl Aisi 316l Nautisch, Hommage an Sardinien. Eleganz, fortschrittliches Design mit Mischer und großem Duschkopf. Einfache Installation mit 3 Befestigungspunkten, für kleine Räume und intensive Nutzung, innen oder außen.

ES

Sined Cabras, Ducha De Pared Negra En Acero Inoxidable Aisi 316l Nautico, Homenaje A Cerdeña. Elegancia, Diseño Avanzado Con Mezclador Y Ducha Grande. Fácil Instalación Con 3 Puntos De Fijación, Para Espacios Pequeños Y Uso Intensivo, En Interiores O Exteriores.

DOCCIA-CHIA-PARETE-INOX

8025431153028

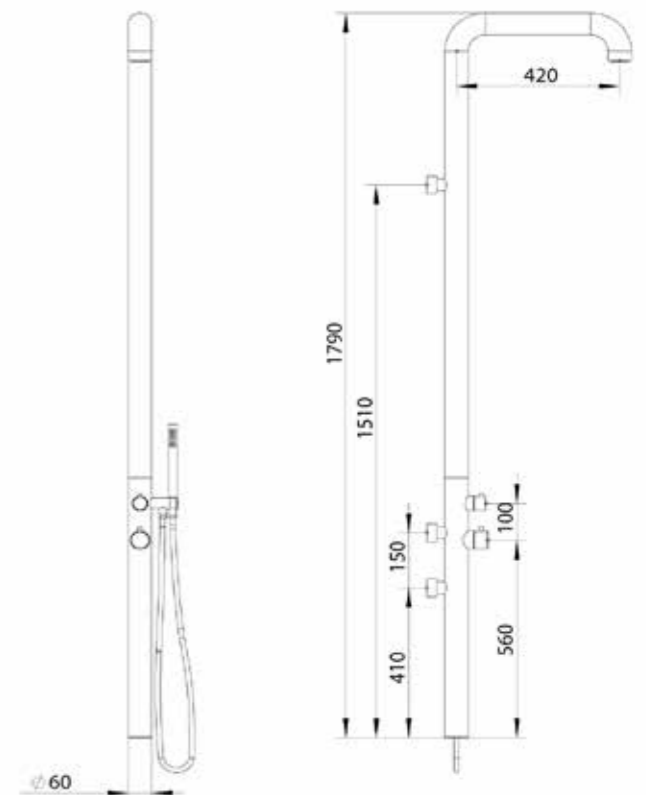
MATERIALE ACCIAIO INOX 316L
MATERIAL 316L STAINLESS**UGELLI ANTICALCARE**
ANTISCALE NOZZLES**PESO 10 KG**
WEIGHT 10 KG**INCLUDE UNA SACCA**
DI PROTEZIONE
INCLUDES A
PROTECTION BAG**ACQUA**
CALDA E FREDDA
WATER
HOT AND COLD**ACCESSORI ACCIAIO INOX 304**
ACCESSORIES STAINLESS STEEL 304**PRODOTTO IN DUE**
PARTI. SCATOLA FACILE DA
MANEGGIARE
PRODUCT IN TWO
PARTS EASY-TO-HANDLE
BOX**GETTO D'ACQUA**
VERTICALE
WATER JET
VERTICAL**IT**

La Doccia Chia Di Sined Unisce Ingegneria e Design Italiano, Acciaio Aisi 316l (nautico) Resistente a Corrosione e Usura. Stile Minimalista, Montaggio a Parete Per Spazi Limitati. Ideale Per Casa e Tutti Gli Spazi Esterni Mare, Terme, Giardino, Piscina.

EN

The Chia Shower by Sined Combines Engineering and Italian Design, Corrosion- and Wear-Resistant Aisi 316l (marine) Steel. Minimalist Style, Wall Mounted For Limited Spaces. Ideal For Home And All Outdoor Spaces Sea, Spa, Garden, Pool.

FR

La douche Chia de Sined combine l'ingénierie et le design italien, l'acier Aisi 316l (marine) résistant à la corrosion et à l'usure. Style minimaliste, montage mural pour les espaces limités. Idéale pour la maison et tous les espaces extérieurs : mer, spa, jardin, piscine.

DE

Die Chia Dusche von Sined kombiniert Technik und italienisches Design, korrosions- und verschleißfester Aisi 316l (Marine) Stahl. Minimalistischer Stil, wandmontiert für begrenzte Räume. Ideal für Haus und alle Außenbereiche Meer, Spa, Garten, Pool.

ES

La ducha Chia de Sined combina ingeniería y diseño italiano, acero Aisi 316l (marino) resistente a la corrosión y al desgaste. Estilo minimalista, montaje en pared para espacios limitados. Ideal para el hogar y todos los espacios al aire libre: mar, spa, jardín, piscina.

DOCCIA-CHIA-PARETE-NERA

8025431153035

MATERIALE ACCIAIO INOX 316L
MATERIAL 316L STAINLESS**UGELLI ANTICALCARE**
ANTISCALE NOZZLES**PESO 10 KG**
WEIGHT 10 KG**INCLUDE UNA SACCA**
DI PROTEZIONE
INCLUDES A
PROTECTION BAG**ACQUA**
CALDA E FREDDA
WATER
HOT AND COLD**ACCESSORI ACCIAIO INOX 304**
ACCESSORIES STAINLESS STEEL 304**PRODOTTO IN DUE**
PARTI. SCATOLA FACILE DA
MANEGGIARE
PRODUCT IN TWO
PARTS EASY-TO-HANDLE
BOX**GETTO D'ACQUA**
VERTICALE
WATER JET
VERTICAL**IT**

Doccia Chia Nera Di Sined: Eccellenza Italiana In Acciaio Aisi 316l, Anti-corrosione e Usura. Design Minimalista e Montaggio a Parete Ideale Per Spazi Ristretti. Perfetta Per Interni Ed Esterni: Casa, Mare, Terme, Giardino, Piscina, Hotel, Campeggio.

EN

Chia Nera Shower by Sined: Italian Excellence in Aisi 316l Steel, Anti-corrosion and Wear. Minimalist Design and Wall Mounting Ideal For Narrow Spaces. Perfect For Indoor And Outdoor: Home, Sea, Spa, Garden, Pool, Hotel, Camping.

FR

Douche Chia Nera par Sined : Excellence italienne en acier Aisi 316l, anti-corrosion et anti-usure. Design minimaliste et montage mural idéal pour les espaces étroits. Parfait pour l'intérieur et l'extérieur : maison, mer, spa, jardin, piscine, hôtel, camping.

DE

Chia Nera Dusche von Sined: Italienische Exzellenz in Aisi 316l Stahl, Anti-Korrosion und Verschleiß. Minimalistisches Design und Wandmontage Ideal für enge Räume. Perfekt für Innen und Außen: Haus, Meer, Spa, Garten, Pool, Hotel, Camping.

ES

Ducha Chia Nera de Sined: Excelencia Italiana en Acero Aisi 316l, Anticorrosión y Antidesgaste. Diseño Minimalista y Montaje En Pared Ideal Para Espacios Estrechos. Perfecta Para Interior Y Exterior: Casa, Mar, Spa, Jardín, Piscina, Hotel, Camping.

**IT**

Sined Pula, Doccia a Parete In Acciaio Inox Aisi 316l Nautico, Omaggio Alla Sardegna. Eleganza, Design Avanzato Con Miscelatore e Ampio Soffione. Facile Installazione Con 3 Punti Di Fissaggio, Per Uso Intensivo, Interni o Esterni, Acqua Calda e Fredda.

**EN**

Sined Pula, Wall Shower In Stainless Steel Aisi 316l Nautical, Homage To Sardinia. Elegance, Advanced Design With Mixer and Large Shower Head. Easy Installation With 3 Fixing Points, For Intensive Use, Indoor or Outdoor, Hot and Cold Water.

FR

Sined Pula, Douche murale en acier inoxydable Aisi 316l Nautisme, hommage à la Sardaigne. Élégance, design avancé avec mitigeur et large pommeau de douche. Installation facile avec 3 points de fixation, pour une utilisation intensive, à l'intérieur ou à l'extérieur, eau chaude et froide.

DE

Sined Pula, Wanddusche aus Edelstahl Aisi 316l Nautisch, Hommage an Sardinien. Eleganz, fortschrittliches Design mit Mischer und großem Duschkopf. Einfache Installation mit 3 Befestigungspunkten, für intensiven Gebrauch, innen oder außen, heißes und

ES

Sined Pula, Ducha De Pared En Acero Inoxidable Aisi 316l Nautico, Homenaje A Cerdeña. Elegancia, Diseño Avanzado Con Mezclador Y Ducha Grande. Fácil Instalación Con 3 Puntos De Fijación, Para Uso Intensivo, Interior O Exterior, Agua Caliente Y Fría.

**DOCCIA-PULA-PARETE-INOX**

8025431153004

MATERIALE ACCIAIO INOX 316L
MATERIAL 316L STAINLESS

UGELLI ANTICALCARE
ANTISCALE NOZZLES

PESO 10 KG
WEIGHT 10 KG

INCLUDE UNA SACCA
DI PROTEZIONE
INCLUDES A
PROTECTION BAG



ACQUA
CALDA E FREDDA
WATER
HOT AND COLD



ACCESSORI ACCIAIO INOX 304
ACCESSORIES STAINLESS STEEL 304

PRODOTTO IN DUE
PARTI. SCATOLA FACILE DA
MANEGGIARE
PRODUCT IN TWO
PARTS EASY-TO-HANDLE
BOX



GETTO D'ACQUA
VERTICALE
WATER JET
VERTICAL

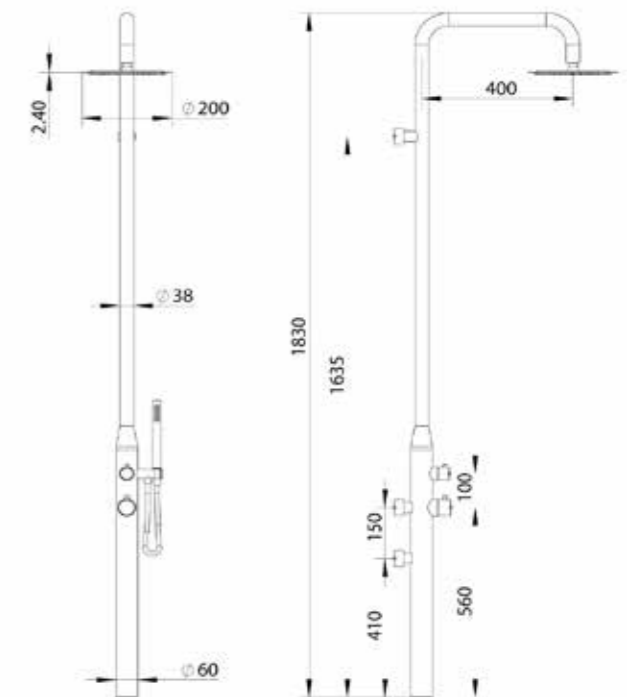

DOCCIA-PULA-PARETE-NERA

8025431153011

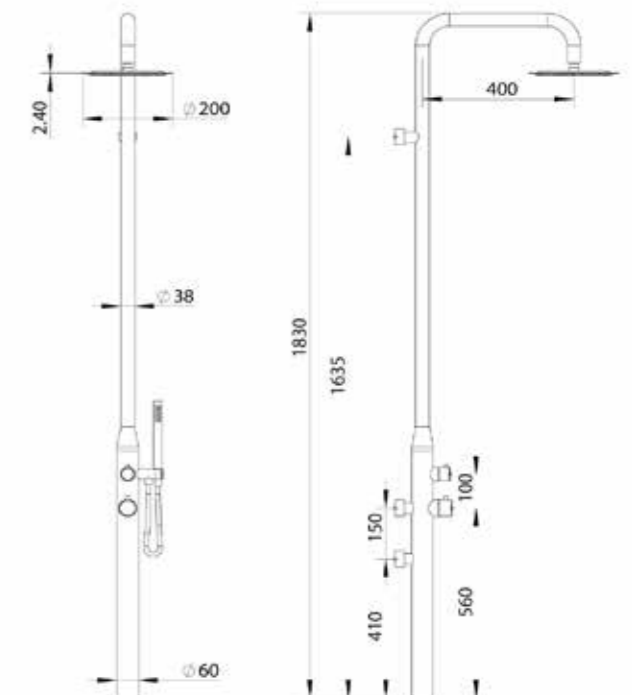
MATERIALE ACCIAIO INOX 316L
MATERIAL 316L STAINLESS**UGELLI ANTICALCARE**
ANTISCALE NOZZLES**PESO 10 KG**
WEIGHT 10 KG**INCLUDE UNA SACCA**
DI PROTEZIONE
INCLUDES A
PROTECTION BAG**ACQUA**
CALDA E FREDDA
WATER
HOT AND COLD**ACCESSORI ACCIAIO INOX 304**
ACCESSORIES STAINLESS STEEL 304**PRODOTTO IN DUE**
PARTI. SCATOLA FACILE DA
MANEGGIARE
PRODUCT IN TWO
PARTS EASY-TO-HANDLE
BOX**GETTO D'ACQUA**
VERTICALE
WATER JET
VERTICAL**IT**

Sined Pula, Doccia Nera a Parete In Acciaio Inox Aisi 316l Nautico, Omaggio Alla Sardegna. Eleganza, Design Avanzato Con Miscelatore e Ampio Soffione. Facile Installazione Con 3 Punti Di Fissaggio, Per Uso Intensivo, Interni o Esterni, Acqua Calda-fredda.

EN

Sined Pula, Black Shower Wall In Stainless Steel Aisi 316l Nautical, Homage To Sardinia. Elegance, Advanced Design With Mixer and Large Shower Head. Easy Installation With 3 Fixing Points, For Intensive Use, Indoor or Outdoor, Hot-Cold Water.

FR

Sined Pula, paroi de douche noire en acier inoxydable Aisi 316l Nautisme, hommage à la Sardaigne. Élégance, design avancé avec mitigeur et large pommeau de douche. Installation facile avec 3 points de fixation, pour un usage intensif, à l'intérieur ou à l'extérieur, eau chaude/froide.

DE

Sined Pula, Schwarze Duschwand aus Edelstahl Aisi 316l Nautisch, Hommage an Sardinien. Eleganz, fortschrittliches Design mit Mischer und großem Duschkopf. Einfache Installation mit 3 Befestigungspunkten, für intensiven Gebrauch, drinnen oder draußen, drinnen oder draußen, drinnen oder draußen, drinnen oder draußen.

ES

Sined Pula, Pared De Ducha Negra En Acero Inoxidable Aisi 316l Nautico, Homenaje A Cerdeña. Elegancia, Diseño Avanzado Con Mezclador Y Ducha Grande. Fácil Instalación Con 3 Puntos De Fijación, Para Uso Intensivo, Interior O Exterior, Agua Caliente-Fría.

DOCCIA-ARBOREA-INOX

8025431018600



IT

Doccia Esterna Per Parete, Per Esterno e Interno. Realizzata In Acciaio Di Ottima Qualità Inox 316L. Doccia Con Ingresso Acqua Calda e Fredda. Doppio Miselatore Per Soffione e Doccino a Mano, Con Valvola a 3 Vie. Ottima Anche In Casa.

EN

Outdoor Wall Shower, For Outdoors and Indoors. Made of High Quality Stainless Steel 316L. Shower with Hot and Cold Water Inlet. Double Mixer for overhead and hand shower, with 3-way valve. Also excellent in the home.

FR

Douche murale d'extérieur, pour l'intérieur et l'extérieur. Fabriquée en acier inoxydable 316L de haute qualité. Douche avec arrivée d'eau chaude et froide. Mitigeur double pour douche de tête et douchette à main, avec robinet à 3 voies. Excellent pour la maison.

DE

Outdoor-Wanddusche, für draußen und drinnen. Hergestellt aus hochwertigem Edelstahl 316L. Dusche mit Warm- und Kaltwassereinlass. Doppelmischer für Kopf- und Handbrause, mit 3-Wege-Ventil. Auch hervorragend für zu Hause geeignet.

ES

Ducha de Pared para Exterior, Para Exterior e Interior. Fabricada en acero inoxidable 316L de alta calidad. Ducha con Entrada de Agua Caliente y Fría. Mezclador doble para ducha mural y teleducha, con válvula de 3 vías. También excelente en el hogar.



MATERIALE ACCIAIO INOX 316L
MATERIAL 316L STAINLESS

UGELLI ANTICALCARE
ANTISCALE NOZZLES

PESO 8,2 KG
WEIGHT 8,2 KG

INCLUDE UNA SACCA
DI PROTEZIONE
INCLUDES A
PROTECTION BAG



GETTO D'ACQUA
VERTICALE
WATER JET
VERTICAL



ACCESSORI ACCIAIO INOX 304
ACCESSORIES STAINLESS STEEL 304

PRODOTTO IN DUE
PARTI. SCATOLA FACILE DA
MANEGGIARE
PRODUCT IN TWO
PARTS EASY-TO-HANDLE
BOX



ACQUA
CALDA E FREDDA
WATER
HOT AND COLD

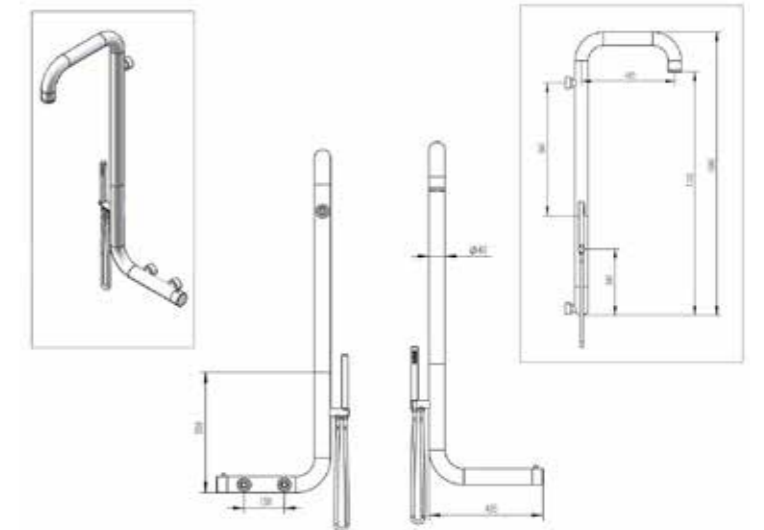

DOCCIA-ARBOREA-NERA

8025431150935



IT

La Doccia Sined Arborea Nera Viene Montata Direttamente a Muro. In Acciaio Di Ottima Qualità Inox 316l. Doccia Con Ingresso Acqua Calda e Fredda. Doppio Miscelatore Per Soffione e Doccino a Mano, Con Valvola a 3 Vie. Ottima Anche In Casa.

EN

The Sined Arborea Black Shower is mounted directly on the wall. Made of high quality 316l stainless steel. Shower with Hot and Cold Water Inlet. Double mixer for overhead and hand shower, with 3-way valve. Also excellent in the home.

FR

La douche Sined Arborea Black se monte directement sur le mur. Fabriquée en acier inoxydable 316l de haute qualité. Douche avec arrivée d'eau chaude et froide. Mitigeur double pour douche de tête et douchette à main, avec vanne à 3 voies. Convient également parfaitement à la maison.

DE

Die Sined Arborea Black Shower wird direkt an der Wand montiert. Hergestellt aus hochwertigem 316l-Edelstahl. Dusche mit Warm- und Kaltwasserzulauf. Doppelmischer für Kopf- und Handbrause, mit 3-Wege-Ventil. Hervorragend auch für den

ES

La ducha Sined Arborea Black se monta directamente en la pared. Fabricada en acero inoxidable 316l de alta calidad. Ducha con entrada de agua caliente y fría. Mezclador doble para ducha mural y teleducha, con válvula de 3 vías. También excelente en el hogar.



MATERIALE ACCIAIO INOX 316L
MATERIAL 316L STAINLESS

UGELLI ANTICALCARE
ANTISCALE NOZZLES

PESO 8,2 KG
WEIGHT 8,2 KG

INCLUDE UNA SACCA
DI PROTEZIONE
INCLUDES A
PROTECTION BAG

GETTO D'ACQUA
VERTICALE
WATER JET
VERTICAL

ACCESSORI ACCIAIO INOX 304
ACCESSORIES STAINLESS STEEL 304

PRODOTTO IN DUE
PARTI. SCATOLA FACILE DA
MANEGGIARE
PRODUCT IN TWO
PARTS EASY-TO-HANDLE
BOX

ACQUA
CALDA E FREDDA
WATER
HOT AND COLD

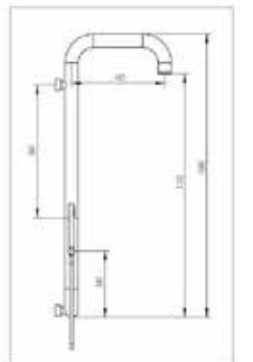
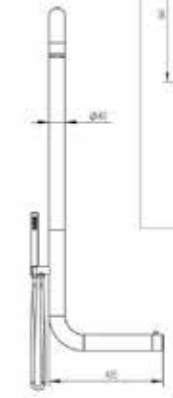

DOCCE LUNA IN ALLUMINIO

ALUMINIUM LUNA SHOWERS

SINED è orgogliosa di presentare la sua linea di docce classiche in alluminio LUNA-ALU. Queste docce, non solo incarnano un design elegante e moderno, ma sono anche sinonimo di funzionalità e versatilità, offrendo un'esperienza unica e confortevole per l'utente. Grazie al loro doppio attacco per l'acqua, sia inferiore che laterale, queste docce si adattano perfettamente a qualsiasi contesto, dalla casa al giardino, diventando un elemento d'arredo raffinato e funzionale.

Le docce LUNA-ALU di SINED sono super accessoriate e progettate per offrire il massimo del comfort. Dotate di un grande soffione, un miscelatore per l'acqua calda e fredda, e un comodo lavapiedi, queste docce sono ideali per chi cerca una soluzione completa e di alto livello.

La valvola a 3 vie integrata rappresenta una delle caratteristiche distintive di queste docce, consentendo un facile collegamento dei tubi per l'acqua calda e fredda, sia inferiormente che lateralmente. Questa flessibilità di installazione rende le docce LUNA-ALU particolarmente adatte a una vasta gamma di applicazioni, come campeggi, villaggi turistici, stabilimenti balneari, hotel, alberghi, piscine, fino ai bagni di casa.

SINED is proud to present its LUNA-ALU line of classic aluminium showers. These showers not only embody an elegant and modern design, but also stand for functionality and versatility, offering a unique and comfortable user experience. Thanks to their double water connection, both bottom and side, these showers fit perfectly into any context, from the home to the garden, becoming a refined and functional piece of furniture. SINED's LUNA-ALU showers are superbly equipped and designed to offer maximum comfort. Equipped with a large shower head, a mixer for hot and cold water, and a convenient footwash, these showers are ideal for those looking for a complete, high-end solution.

The integrated 3-way valve is one of the distinguishing features of these showers, allowing easy connection of the hot and cold water hoses, both at the bottom and at the side. This installation flexibility makes the LUNA-ALU showers particularly suitable for a wide range of applications, such as campsites, holiday resorts, bathing establishments, hotels, swimming pools, and even home bathrooms.





IT

Doccia Bianca Luna
In Alluminio Acqua
Calda e Fredda Sined
Con Miscelatore Per
La Temperatura e Per
Il Lavapiedi. Doppio
Attacco Acqua, Inferiore
e Laterale, Installabile
Sia Internamente Che
Esternamente All'abitazione,
Riccamente Accessoriata.

EN

Sined White Moon Shower
in Aluminium Hot and
Cold Water with Mixer for
Temperature and Footwash.
Double water connection,
bottom and side, can be
installed both inside and
outside the house, richly
equipped.

FR

Douche blanche Sined Moon
en aluminium Eau chaude
et froide avec mitigeur de
température et lave-pieds.
Double raccordement à l'eau,
inférieur et latéral, pouvant
être installé à l'intérieur et
à l'extérieur de la maison,
richement équipé.

DE

Sined White Moon Dusche
aus Aluminium Warm- und
Kaltwasser mit Mischer
für Temperatur und
Fußspülung. Doppelter
Wasseranschluss,
unten und seitlich, kann
sowohl innerhalb als
auch außerhalb des
Hauses installiert werden,
reichhaltig ausgestattet.

ES

Sined Ducha Moon Blanca
en Aluminio Agua Caliente
y Fría con Mezclador para
Temperatura y Lavapies.
Doble toma de agua,
inferior y lateral, puede
instalarse tanto en el
interior como en el exterior
de la vivienda, ricamente
equipada.

LUNA-ALU-BIANCA

8025431152670

MATERIALE ALLUMINIO
ESTRUSO AA 6063
MATERIAL EXTRUSION
ALUMINUM AA 6063
UGELLI ANTICALCARE
ANTISCALE NOZZLES

PESO 8 KG
WEIGHT 8 KG

INCLUDE UNA SACCA
DI PROTEZIONE
INCLUDES A
PROTECTION BAG



SINED IN ESCLUSIVA MONDIALE!
DOBPIO INGRESSO ACQUA
LATERALE O INFERIORE
SINED WORLD WIDE EXCLUSIVE!
DOUBLE WATER INLET
SIDE OR BOTTOM

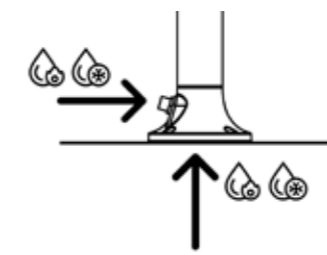

ACQUA
CALDA E FREDDA
WATER
HOT AND COLD



GETTO D'ACQUA
VERTICALE
WATER JET
VERTICAL



(mm)

ACCESSORI ACCIAIO INOX 304
ACCESSORIES STAINLESS STEEL 304

DUE FILTRI ANTICALCARE INCLUSI
TWO ANTI-SCALE FILTERS INCLUDED

VERNICIATURA ELETTROSTATICA A
POLVERE DI QUALITÀ AUTOMOBILISTICA
AUTOMOTIVE QUALITY ELECTROSTATIC
POWDER COATING

PRODOTTO IN DUE
PARTI. SCATOLA FACILE DA
MANEGGIARE
PRODUCT IN TWO
PARTS EASY-TO-HANDLE
BOX

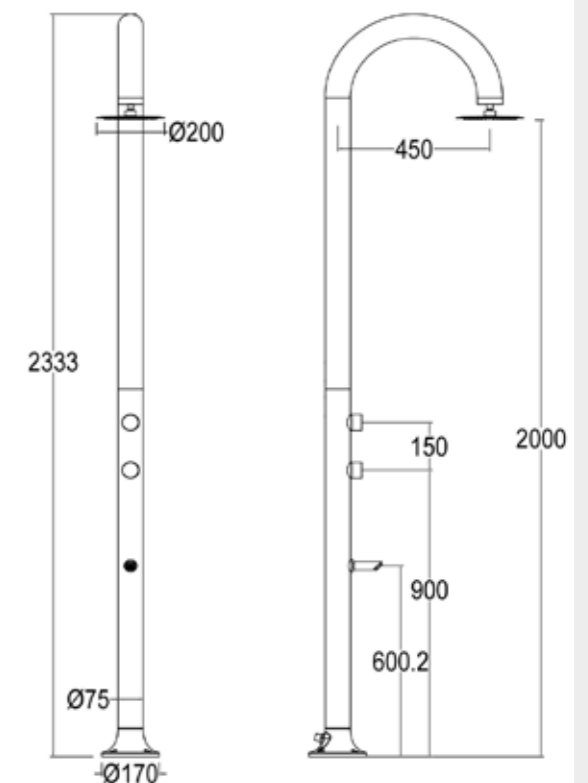

**IT**

Doccia Grigia Luna
In Alluminio Acqua
Calda e Fredda Sined
Con Miscelatore Per
La Temperatura e Per
Il Lavapiedi. Doppio
Attacco Acqua, Inferiore
e Laterale, Installabile
Sia Internamente Che
Esternamente All'abitazione,
Riccamente Accessoriata.

EN

Sined Grey Moon Shower
in Aluminium Hot and Cold
Water with Temperature and
Footwash Mixer. Double
water connection, bottom
and side, can be installed
both inside and outside the
house, richly equipped.

FR

Douche Moon Grey Sined
en aluminium Eau chaude
et froide avec température
et mitigeur lave-pieds.
Double raccordement à l'eau,
inférieur et latéral, pouvant
être installé à l'intérieur
comme à l'extérieur de la
maison, richement équipé.

DE

Sined Grey Moon Dusche
aus Aluminium Warm- und
Kaltwasser mit Temperatur
und Fußwaschmischer.
Doppelter Wasseranschluss,
unten und seitlich, kann
sowohl innerhalb als
auch außerhalb des
Hauses installiert werden,
reichhaltig ausgestattet.

ES

Ducha Sined Gris Moon
en Aluminio Agua Caliente
y Fría con Mezclador de
Temperatura y Lavapies.
Doble toma de agua,
inferior y lateral, puede
instalarse tanto en el
interior como en el exterior
de la vivienda, ricamente
equipada.

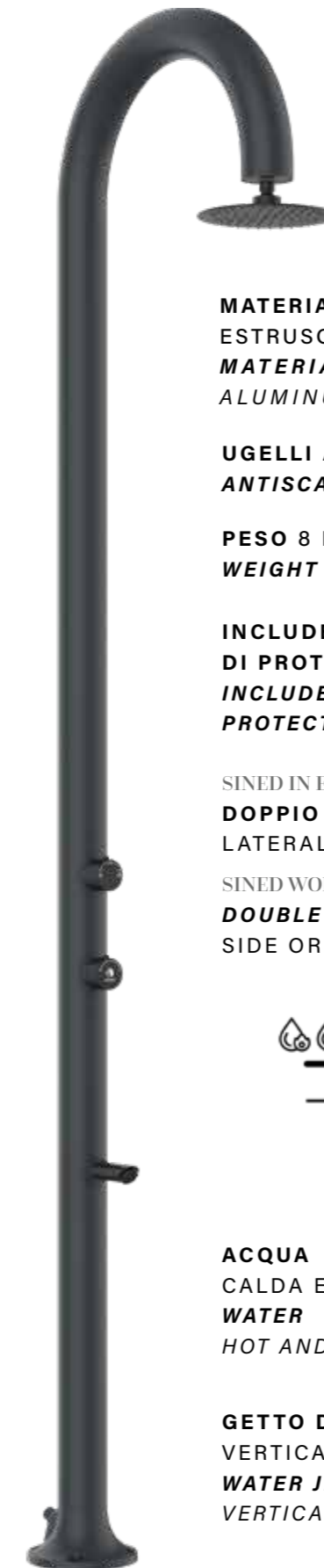
**LUNA-ALU-GRIGIA**

8025431152830

MATERIALE ALLUMINIO
ESTRUSO AA 6063
MATERIAL EXTRUSION
ALUMINUM AA 6063

UGELLI ANTICALCARE
ANTISCALE NOZZLES

PESO 8 KG
WEIGHT 8 KG

INCLUDE UNA SACCA
DI PROTEZIONE
INCLUDES A
PROTECTION BAG



SINED IN ESCLUSIVA MONDIALE!
DOBPIO INGRESSO ACQUA
LATERALE O INFERIORE

SINED WORLD WIDE EXCLUSIVE!
DOUBLE WATER INLET
SIDE OR BOTTOM

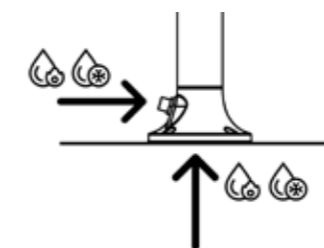

ACQUA
CALDA E FREDDA
WATER
HOT AND COLD



GETTO D'ACQUA
VERTICALE
WATER JET
VERTICAL

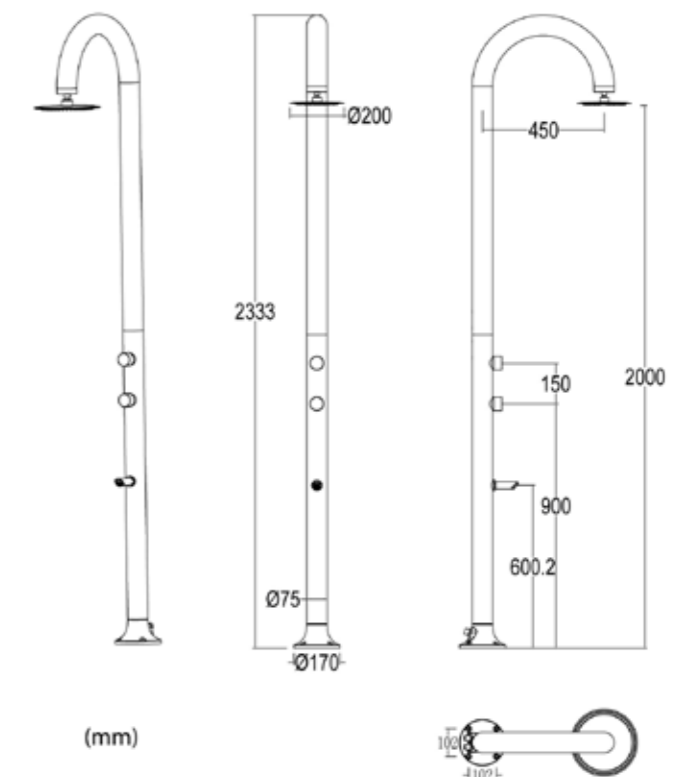

ACCESSORI ACCIAIO INOX 304
ACCESSORIES STAINLESS STEEL 304

DUE FILTRI ANTICALCARE INCLUSI
TWO ANTI-SCALE FILTERS INCLUDED

VERNICIATURA ELETTROSTATICA A
POLVERE DI QUALITÀ AUTOMOBILISTICA
AUTOMOTIVE QUALITY ELECTROSTATIC
POWDER COATING



PRODOTTO IN DUE
PARTI. SCATOLA FACILE DA
MANEGGIARE
PRODUCT IN TWO
PARTS EASY-TO-HANDLE
BOX

**IT**

Doccia Nera Luna
In Alluminio Acqua
Calda e Fredda Sined
Con Miselatore Per
La Temperatura e Per
Il Lavapiedi. Doppio
Attacco Acqua, Inferiore
e Laterale, Installabile
Sia Internamente Che
Esternamente All'abitazione,
Riccamente Accessoriata.

EN

Black Luna Aluminium
Shower Hot and Cold Water
Sined With Temperature
and Footwash Mixer.
Double Water Connection,
Bottom and Side, Installable
Both Inside and Outside the
House, Richly Equipped.

FR

Douche en aluminium Black
Luna Eau chaude et froide
combinée avec mitigeur de
température et lave-pieds.
Double raccordement à
l'eau, en bas et sur le côté,
installable aussi bien à
l'intérieur qu'à l'extérieur de
la maison, richement équipée.

DE

Schwarze Luna Aluminium
Dusche Warm- und
Kaltwasser mit Temperatur
und Fußwaschmischer.
Doppelter Wasseranschluss,
unten und seitlich,
sowohl innerhalb als auch
außerhalb des Hauses
installierbar, reichhaltig
bestückt.

ES

Ducha de Aluminio Luna
Negra Agua Caliente y Fría
Sined Con Mezclador de
Temperatura y Lavapies.
Doble Conexión De
Agua, Inferior Y Lateral,
Instalable Tanto Dentro
Como Fuera De La Casa,
Ricamento Equipada.

LUNA-ALU-NERA

8025431152793

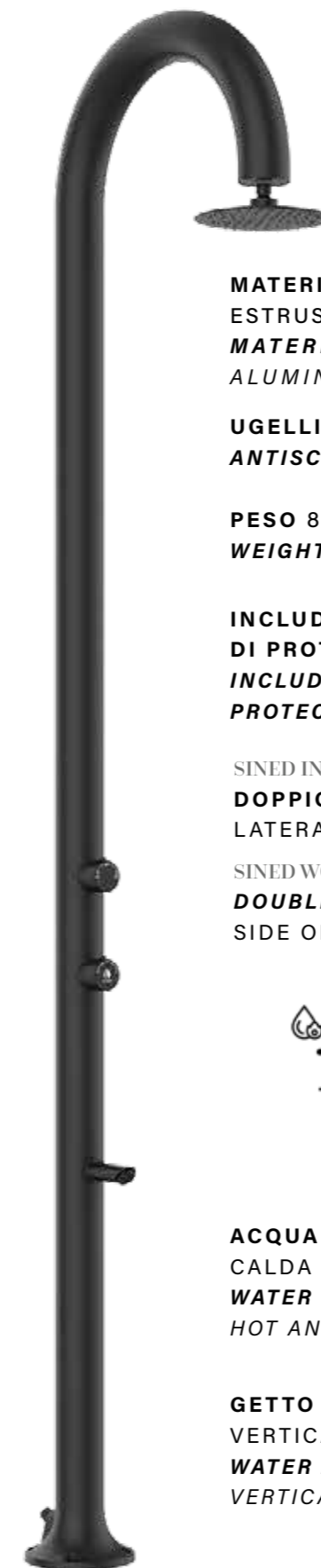

MATERIALE ALLUMINIO
ESTRUSO AA 6063
MATERIAL EXTRUSION
ALUMINUM AA 6063

UGELLI ANTICALCARE
ANTISCALE NOZZLES

PESO 8 KG
WEIGHT 8 KG

INCLUDE UNA SACCA
DI PROTEZIONE
INCLUDES A
PROTECTION BAG



SINED IN ESCLUSIVA MONDIALE!
DOPPIO INGRESSO ACQUA
LATERALE O INFERIORE

SINED WORLD WIDE EXCLUSIVE!
DOUBLE WATER INLET
SIDE OR BOTTOM

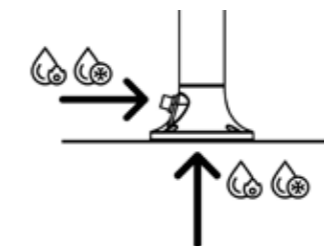

ACQUA
CALDA E FREDDA
WATER
HOT AND COLD



GETTO D'ACQUA
VERTICALE
WATER JET
VERTICAL



(mm)

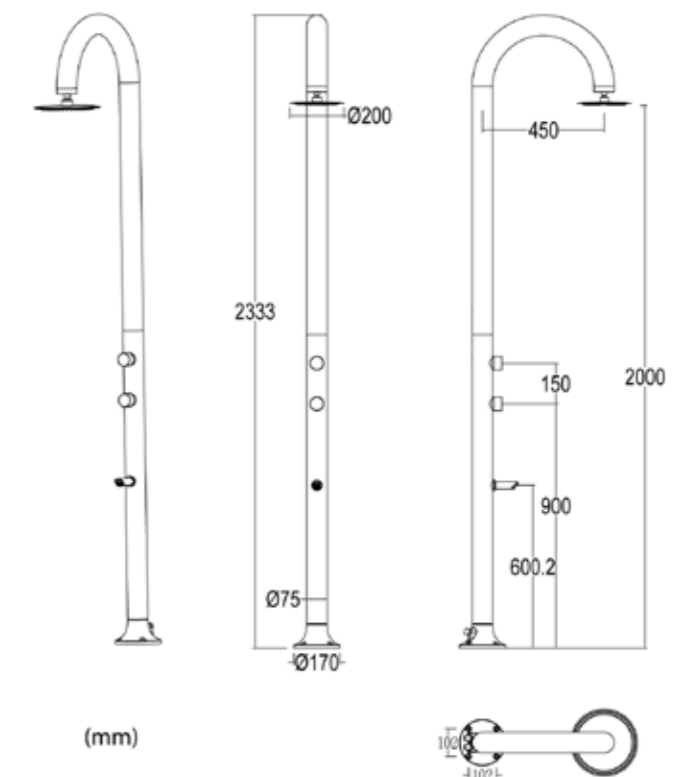

ACCESSORI ACCIAIO INOX 304
ACCESSORIES STAINLESS STEEL 304

DUE FILTRI ANTICALCARE INCLUSI
TWO ANTI-SCALE FILTERS INCLUDED

VERNICIATURA ELETTROSTATICA A
POLVERE DI QUALITÀ AUTOMOBILISTICA
AUTOMOTIVE QUALITY ELECTROSTATIC
POWDER COATING

PRODOTTO IN DUE
PARTI. SCATOLA FACILE DA
MANEGGIARE
PRODUCT IN TWO
PARTS EASY-TO-HANDLE
BOX



LUNA-ALU-NERA-ORO

8025431153219

MATERIALE ALLUMINIO
ESTRUSO AA 6063
MATERIAL EXTRUSION
ALUMINUM AA 6063

UGELLI ANTICALCARE
ANTISCALE NOZZLES

PESO 8 KG
WEIGHT 8 KG

INCLUDE UNA SACCA
DI PROTEZIONE
INCLUDES A
PROTECTION BAG



SINED IN ESCLUSIVA MONDIALE!
DOBPIO INGRESSO ACQUA
LATERALE O INFERIORE

SINED WORLD WIDE EXCLUSIVE!
DOUBLE WATER INLET
SIDE OR BOTTOM

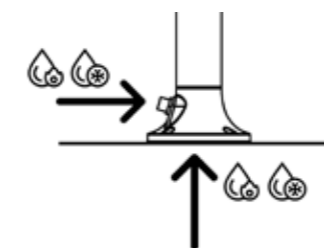

ACQUA
CALDA E FREDDA
WATER
HOT AND COLD



GETTO D'ACQUA
VERTICALE
WATER JET
VERTICAL



(mm)

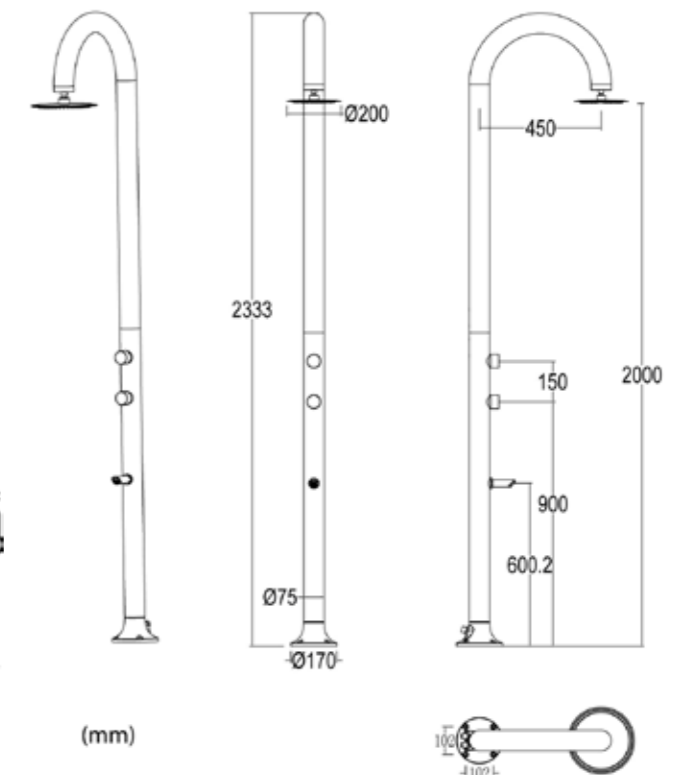

ACCESSORI ACCIAIO INOX 304
ACCESSORIES STAINLESS STEEL 304

DUE FILTRI ANTICALCARE INCLUSI
TWO ANTI-SCALE FILTERS INCLUDED

VERNICIATURA ELETTROSTATICA A
POLVERE DI QUALITÀ AUTOMOBILISTICA
AUTOMOTIVE QUALITY ELECTROSTATIC
POWDER COATING

PRODOTTO IN DUE
PARTI. SCATOLA FACILE DA
MANEGGIARE
PRODUCT IN TWO
PARTS EASY-TO-HANDLE
BOX



IT

Elegante Doccia Alluminio Nero e Oro, Progettata Con Soffione Circolare e Ugelli Anticalcare Per Un'esperienza D'acqua Calda o Fredda Senza Uguali. Con Doppio Attacco Per L'acqua, Si Adatta Perfettamente Sia Agli Spazi Interni Che Esterni Della Casa.

EN

Elegant Black and Gold Aluminium Shower, Designed With Circular Showerhead and Anti-Limescale Nozzles For An Unparalleled Hot or Cold Water Experience. With a dual water connection, it fits perfectly in both indoor and outdoor spaces.

FR

Douche élégante en aluminium noir et or, dotée d'une pomme de douche circulaire et de buses anticalcaires pour une expérience inégalée de l'eau chaude ou froide. Dotée d'un double raccordement à l'eau, elle s'intègre parfaitement dans les espaces intérieurs et extérieurs.

DE

Elegante schwarz-goldene Aluminiumdusche mit kreisförmigem Duschkopf und Anti-Kalk-Düsen für ein unvergleichliches Heiß- oder Kaltwassererlebnis. Mit einem doppelten Wasseranschluss passt sie perfekt in Innen- und Außenbereiche.

ES

Elegante ducha de aluminio negro y dorado, diseñada con rociador circular y boquillas antical para una experiencia inigualable de agua fría o caliente. Con Doble Conexión De Agua, Se Adapta Perfectamente Tanto A Espacios Interiores Como Exteriores.

**IT**

Doccia Bianca In Alluminio Luna Con Doccino Mobile Acqua Calda e Fredda e Miscelatore, Soffione Rotondo Ugelli Anticalcare. Doppio Attacco Acqua, Inferiore e Laterale. Ideale Per Tutte Le Attività All'esterno o Posizionabile All'interno Della Abitazione.

EN

White Aluminium Luna Shower with Mobile Hot and Cold Water Shower and Mixer, Round Overhead Shower, Anti-Limescale Nozzles. Double Water Connection, Bottom and Side. Ideal for all outdoor activities or for placement inside the home.

FR

Douche Luna en aluminium blanc avec douche mobile et mitigeur d'eau chaude et froide, douche de tête ronde, buses anti-calcaire. Double raccordement à l'eau, en bas et sur le côté. Idéale pour toutes les activités de plein air ou pour un placement à l'intérieur de la maison.

DE

Luna Dusche aus weißem Aluminium mit mobiler Warm- und Kaltwasserdusche und Mischer, runder Kopfbrause, Antikalk-Düsen. Doppelter Wasseranschluss, unten und seitlich. Ideal für alle Outdoor-Aktivitäten oder für die Platzierung innerhalb des Hauses.

ES

Ducha Luna de Aluminio Blanco con Mezclador y Ducha Móvil de Agua Caliente y Fría, Ducha Superior Redonda, Boquillas Antical. Doble Toma de Agua, Inferior y Lateral. Ideal para todas las actividades al aire libre o para colocar dentro de casa.

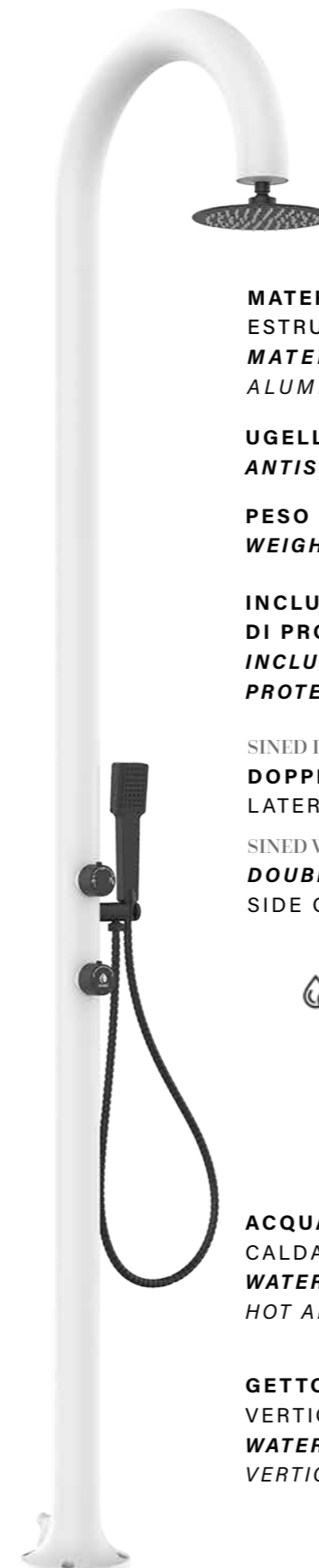
**LUNA-ALU-D-BIANCA**

8025431152717

MATERIALE ALLUMINIO
ESTRUSO AA 6063
MATERIAL EXTRUSION
ALUMINUM AA 6063

UGELLI ANTICALCARE
ANTISCALE NOZZLES

PESO 8 KG
WEIGHT 8 KG

INCLUDE UNA SACCA
DI PROTEZIONE
INCLUDES A
PROTECTION BAG



SINED IN ESCLUSIVA MONDIALE!
DOBPIO INGRESSO ACQUA
LATERALE O INFERIORE

SINED WORLD WIDE EXCLUSIVE!
DOUBLE WATER INLET
SIDE OR BOTTOM

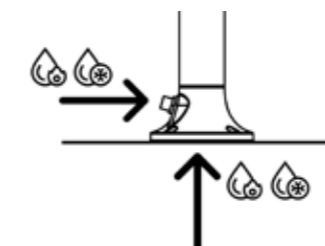

ACQUA
CALDA E FREDDA
WATER
HOT AND COLD



GETTO D'ACQUA
VERTICALE
WATER JET
VERTICAL



(mm)

ACCESSORI ACCIAIO INOX 304
ACCESSORIES STAINLESS STEEL 304

DUE FILTRI ANTICALCARE INCLUSI
TWO ANTI-SCALE FILTERS INCLUDED

DOCCINO FLESSIBILE
FLEXIBLE HANDSHOWER

VERNICIATURA ELETTROSTATICA A
POLVERE DI QUALITÀ AUTOMOBILISTICA
AUTOMOTIVE QUALITY ELECTROSTATIC
POWDER COATING



PRODOTTO IN DUE
PARTI. SCATOLA FACILE DA
MANEGGIARE
PRODUCT IN TWO
PARTS EASY-TO-HANDLE
BOX

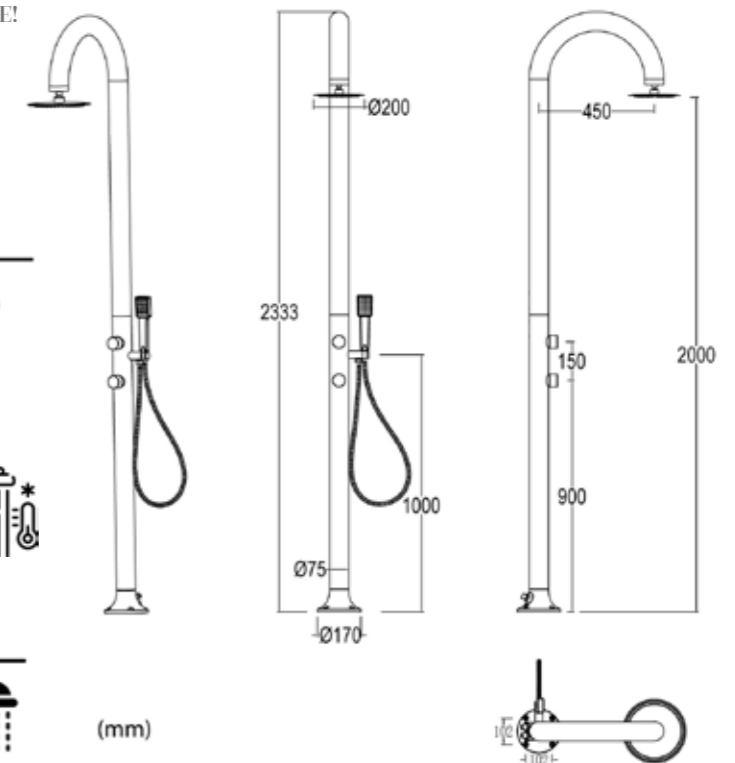

LUNA-ALU-D-GRIGIA

8025431152878

MATERIALE ALLUMINIO
ESTRUSO AA 6063
MATERIAL EXTRUSION
ALUMINUM AA 6063

UGELLI ANTICALCARE
ANTISCALE NOZZLES

PESO 8 KG
WEIGHT 8 KG

INCLUDE UNA SACCA
DI PROTEZIONE
INCLUDES A
PROTECTION BAG



SINED IN ESCLUSIVA MONDIALE!
DOBPIO INGRESSO ACQUA
LATERALE O INFERIORE

SINED WORLD WIDE EXCLUSIVE!
DOUBLE WATER INLET
SIDE OR BOTTOM

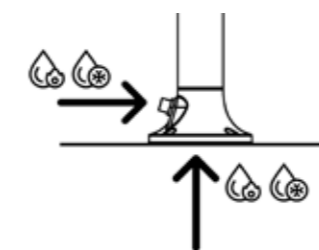

ACQUA
CALDA E FREDDA
WATER
HOT AND COLD



GETTO D'ACQUA
VERTICALE
WATER JET
VERTICAL



(mm)

ACCESSORI ACCIAIO INOX 304
ACCESSORIES STAINLESS STEEL 304

DUE FILTRI ANTICALCARE INCLUSI
TWO ANTI-SCALE FILTERS INCLUDED

DOCCINO FLESSIBILE
FLEXIBLE HANDSHOWER

VERNICIATURA ELETTROSTATICA A
POLVERE DI QUALITÀ AUTOMOBILISTICA
AUTOMOTIVE QUALITY ELECTROSTATIC
POWDER COATING

PRODOTTO IN DUE
PARTI. SCATOLA FACILE DA
MANEGGIARE
PRODUCT IN TWO
PARTS EASY-TO-HANDLE
BOX

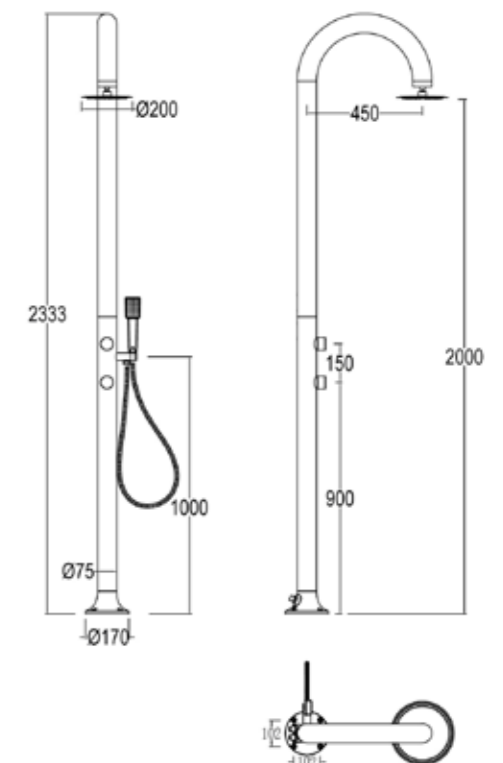

IT

Sistema Doccia In Alluminio, Colore Grigio, Con Funzione Acqua Calda e Fredda. Dotato Di Soffione Rotondo Anticalcare e Doppio Attacco Acqua. Ideale Per Giardini, Piscine, Campeggi, Hotel, Stabilimenti Balneari, Terme.

EN

Aluminium Shower System, Colour Grey, With Hot and Cold Water Function. Equipped with a round anti-limescale shower head and double water connection. Ideal For Gardens, Pools, Campsites, Hotels, Bathing Establishments, Spas.

FR

Système de douche en aluminium, couleur gris, avec fonction eau chaude et eau froide. Equipé d'une pomme de douche ronde anti-calcaire et d'un double raccord d'eau. Idéal pour les jardins, les piscines, les campings, les hôtels, les établissements de bains, les spas.

DE

Aluminium-Duschanlage, Farbe Grau, mit Warm- und Kaltwasserfunktion. Ausgestattet mit einem runden Anti-Kalk-Duschkopf und doppeltem Wasseranschluss. Ideal für Gärten, Pools, Campingplätze, Hotels, Badeanstalten, Spas.

ES

Sistema de ducha de aluminio, color gris, con función de agua caliente y fría. Equipado con un cabezal de ducha redondo antical y doble conexión de agua. Ideal para jardines, piscinas, campings, hoteles, balnearios y spas.

**IT**

Doccia Nera In Alluminio
Con Doccino Mobile Acqua
Calda e Fredda, Soffione
Rotondo Con Ugelli
Anticalcare. Doppio Attacco
Acqua, Inferiore e Laterale.
Per Tutte Le Attività
Esterne e Interne, Private
e Commerciali. Per Grandi
Carichi Di Lavoro.

EN

Black Aluminium Shower
With Hot and Cold Water
Hand Shower, Round
Shower Head With Anti-
Limescale Nozzles. Double
Water Connection, Bottom
and Side. For all outdoor
and indoor activities, private
and commercial. For large
workloads.

FR

Douche en aluminium noir
avec douchette à main à eau
chaude et froide, pommeau
de douche rond avec buses
anticalcaires. Double
raccordement à l'eau, en bas
et sur le côté. Pour toutes
les activités extérieures
et intérieures, privées et
commerciales. Pour les
grandes charges de travail.

DE

Schwarze Aluminiumdusche
mit Warm- und Kaltwasser-
Handbrause, runder
Duschkopf mit Antikalk-
Düsen. Doppelter
Wasseranschluss, unten
und seitlich. Für alle Außen-
und Innenaktivitäten, privat
und gewerblich. Für große
Arbeitsmengen.

ES

Ducha de Aluminio Negro
con Teleducha de Agua
Caliente y Fría, Rociador
Redondo con Boquillas
Antical. Doble Toma de
Agua, Inferior y Lateral.
Para todas las actividades
al aire libre y en interiores,
privadas y comerciales.
Para grandes cargas de
trabajo.

LUNA-ALU-D-NERA

8025431152755

**MATERIALE ALLUMINIO
ESTRUSO AA 6063
MATERIAL EXTRUSION
ALUMINUM AA 6063**

**UGELLI ANTICALCARE
ANTISCALE NOZZLES**

**PESO 8 KG
WEIGHT 8 KG**

**INCLUDE UNA SACCA
DI PROTEZIONE
INCLUDES A
PROTECTION BAG**



**SINED IN ESCLUSIVA MONDIALE!
DOPPIO INGRESSO ACQUA
LATERALE O INFERIORE**

**SINED WORLD WIDE EXCLUSIVE!
DOUBLE WATER INLET
SIDE OR BOTTOM**

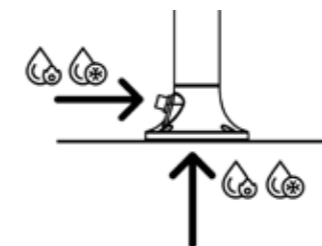

**ACQUA
CALDA E FREDDA
WATER
HOT AND COLD**



**GETTO D'ACQUA
VERTICALE
WATER JET
VERTICAL**



(mm)

**ACCESSORI ACCIAIO INOX 304
ACCESSORIES STAINLESS STEEL 304**

**DUE FILTRI ANTICALCARE INCLUSI
TWO ANTI-SCALE FILTERS INCLUDED**

**VERNICIATURA ELETTROSTATICA A
POLVERE DI QUALITÀ AUTOMOBILISTICA
AUTOMOTIVE QUALITY ELECTROSTATIC
POWDER COATING**

**DOCCINO FLESSIBILE
FLEXIBLE HANDSHOWER**

**PRODOTTO IN DUE
PARTI. SCATOLA FACILE DA
MANEGGIARE
PRODUCT IN TWO
PARTS EASY-TO-HANDLE
BOX**

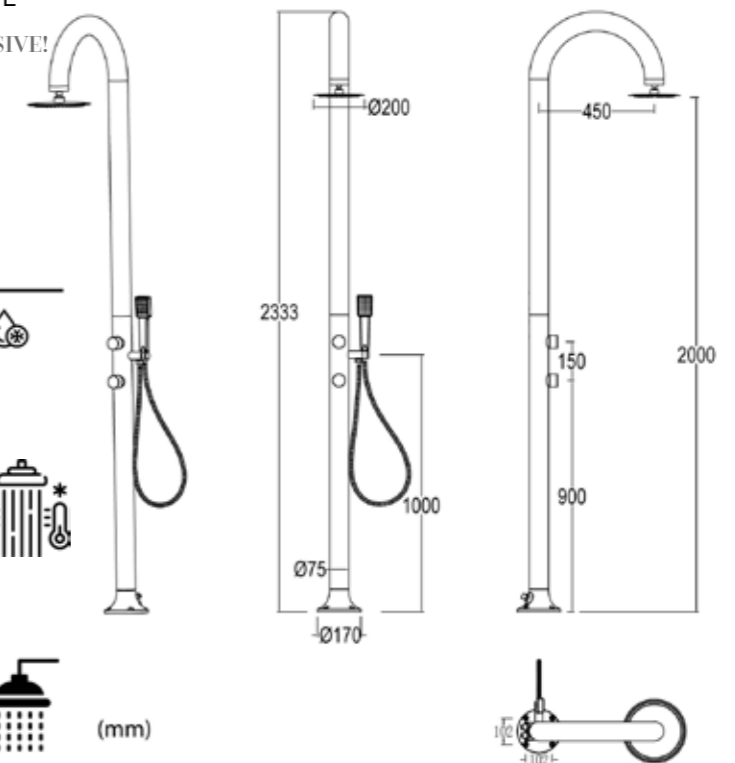

**IT**

Doccia Nera e Oro In Alluminio Con Doccino Mobile Acqua Calda e Fredda, Soffione Rotondo Ugelli Anticalcare. Doppio Attacco Acqua, Inferiore e Laterale. Posizionabile All'esterno o All'interno Della Abitazione.

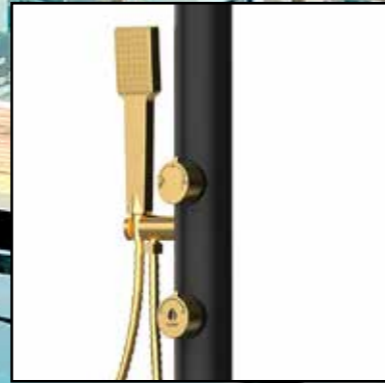
**EN**

Black and Gold Aluminium Shower With Hot and Cold Water Hand Shower, Round Overhead Shower Nozzles Anti-Limescale. Double Water Connection, Bottom and Side. Can be positioned outside or inside the home.

FR

Douche en aluminium noir et or avec douchette à main à eau chaude et froide, buses de douche de tête rondes anti-calcaire. Double raccordement à l'eau, en bas et sur le côté. Peut être placée à l'extérieur ou à l'intérieur de la maison.

DE

Schwarz-goldene Aluminium-Dusche mit Warm- und Kaltwasser-Handbrause, runde Kopfbrause-Düsen mit Anti-Kalk-Effekt. Doppelter Wasseranschluss, unten und seitlich. Kann außerhalb oder innerhalb des Hauses positioniert werden.

ES

Ducha de Aluminio Negro con Teleducha de Agua Caliente y Fría, Rociador Redondo con Boquillas Antical. Doble Toma de Agua, Inferior y Lateral. Para todas las actividades al aire libre y en interiores, privadas y comerciales. Para grandes cargas de trabajo.

**LUNA-ALU-D-NERA-ORO**

8025431153226

MATERIALE ALLUMINIO
ESTRUSO AA 6063
MATERIAL EXTRUSION
ALUMINUM AA 6063

UGELLI ANTICALCARE
ANTISCALE NOZZLES

PESO 8 KG
WEIGHT 8 KG

INCLUDE UNA SACCA
DI PROTEZIONE
INCLUDES A
PROTECTION BAG



SINED IN ESCLUSIVA MONDIALE!
DOBPIO INGRESSO ACQUA
LATERALE O INFERIORE

SINED WORLD WIDE EXCLUSIVE!
DOUBLE WATER INLET
SIDE OR BOTTOM

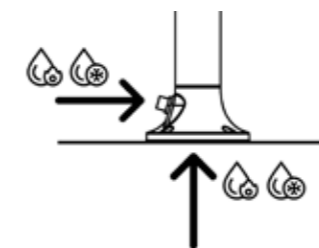

ACQUA
CALDA E FREDDA
WATER
HOT AND COLD



GETTO D'ACQUA
VERTICALE
WATER JET
VERTICAL



(mm)

ACCESSORI ACCIAIO INOX 304
ACCESSORIES STAINLESS STEEL 304

DUE FILTRI ANTICALCARE INCLUSI
TWO ANTI-SCALE FILTERS INCLUDED

VERNICIATURA ELETTROSTATICA A
POLVERE DI QUALITÀ AUTOMOBILISTICA
AUTOMOTIVE QUALITY ELECTROSTATIC
POWDER COATING

DOCCINO FLESSIBILE
FLEXIBLE HANDSHOWER

PRODOTTO IN DUE
PARTI. SCATOLA FACILE DA
MANEGGIARE
PRODUCT IN TWO
PARTS EASY-TO-HANDLE
BOX

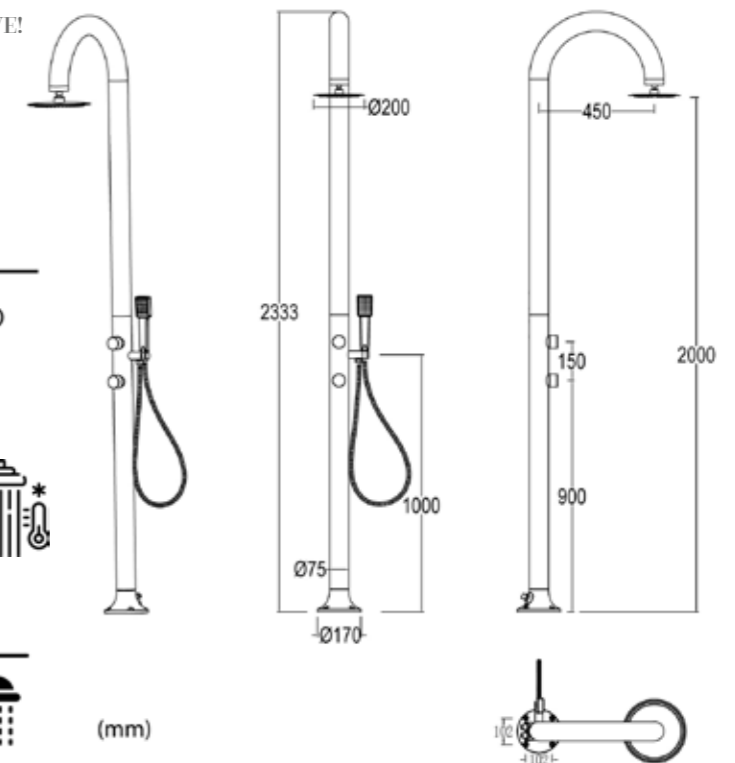

LUNA-TIMER-BIANCA

8025431152915

**MATERIALE ALLUMINIO
ESTRUSO AA 6063
MATERIAL EXTRUSION
ALUMINUM AA 6063**

**UGELLI ANTICALCARE
ANTISCALE NOZZLES**

**PESO 8 KG
WEIGHT 8 KG**

**INCLUDE UNA SACCA
DI PROTEZIONE
INCLUDES A
PROTECTION BAG**



**SINED IN ESCLUSIVA MONDIALE!
DOPPIO INGRESSO ACQUA
LATERALE O INFERIORE**

**SINED WORLD WIDE EXCLUSIVE!
DOUBLE WATER INLET
SIDE OR BOTTOM**

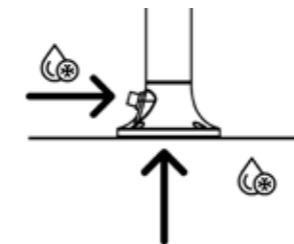

**ACQUA FREDDA
COLD WATER**



**GETTO D'ACQUA
VERTICAL
WATER JET
VERTICAL**



**FUNZIONE TIMER
TIMER FUNCTION**



**ACCESSORI ACCIAIO INOX 304
ACCESSORIES STAINLESS STEEL 304**

**FILTRO ANTICALCARE INCLUSO
FILTER LIMESCALE INCLUDED**

**VERNICIATURA A POLVERE
ELETTROSTATICA DI QUALITÀ
AUTOMOBILISTICA. AUTOMOTIVE QUALITY
ELECTROSTATIC POWDER COATING**

**PRODOTTO IN DUE
PARTI. SCATOLA FACILE DA
MANEGGIARE
PRODUCT IN TWO
PARTS EASY-TO-HANDLE
BOX**

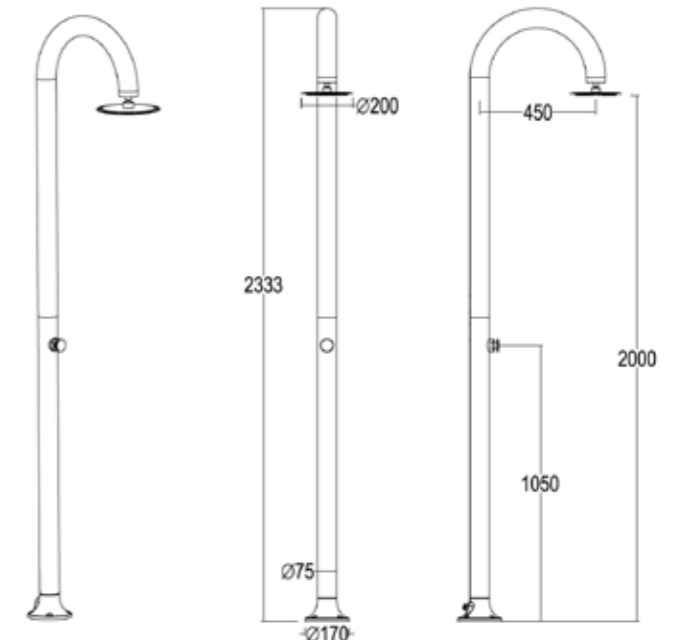

(mm)



IT

Doccia Bianca In Alluminio Temporizzata. Solo Acqua Fredda, Miscelatore Per Regolare Il Flusso Dell'acqua. Doppio Attacco Acqua, Inferiore e Laterale. Per Esterni o Interni Della Abitazione. Ideale Per Grandi Carichi Di Lavoro e Grande Risparmio Acqua.

EN

White Aluminium Timed Shower. Cold water only, mixer to regulate water flow. Double Water Connection, Bottom and Side. For outdoors or indoors. Ideal For Large Workloads And Large Water Saving.

FR

Douche temporisée en aluminium blanc. Eau froide uniquement, mitigeur pour réguler le débit d'eau. Double raccordement à l'eau, en bas et sur le côté. Pour l'extérieur ou l'intérieur. Idéale pour les grandes charges de travail et les grandes économies d'eau.

DE

Zeitgesteuerte Dusche aus weißem Aluminium. Nur Kaltwasser, Mischer zur Regulierung des Wasserflusses. Doppelter Wasseranschluss, unten und seitlich. Für draußen oder drinnen. Ideal für große Arbeitsbelastungen und große Wassereinsparungen.

ES

Ducha temporizada de aluminio blanco. Sólo agua fría, mezclador para regular el caudal de agua. Doble toma de agua, inferior y lateral. Para exterior o interior. Ideal Para Grandes Cargas De Trabajo Y Gran Ahorro De Agua.

**IT**

Doccia Grigia In Alluminio Temporizzata. Solo Acqua Fredda, Miscelatore Per Regolare Il Flusso Dell'acqua. Doppio Attacco Acqua, Inferiore e Laterale. Per Esterni o Interni Della Abitazione. Ideale Per Grandi Carichi Di Lavoro Con Grande Risparmio Acqua.

EN

Grey Aluminium Timed Shower. Cold water only, mixer to regulate water flow. Double Water Connection, Bottom and Side. For outdoors or indoors. Ideal For Large Workloads With Great Water Saving.

FR

Douche temporisée en aluminium gris. Eau froide uniquement, mitigeur pour réguler le débit d'eau. Double raccordement à l'eau, en bas et sur le côté. Pour l'extérieur ou l'intérieur. Idéale pour les grandes charges de travail avec une grande économie d'eau.

DE

Grau Aluminium Zeitgesteuerte Dusche. Nur Kaltwasser, Mischer zur Regulierung des Wasserflusses. Doppelter Wasseranschluss, unten und seitlich. Für draußen oder drinnen. Ideal für große Arbeitsbelastungen mit großer Wassereinsparung.

ES

Ducha temporizada de aluminio gris. Sólo agua fría, mezclador para regular el caudal de agua. Doble toma de agua, inferior y lateral. Para exterior o interior. Ideal Para Grandes Cargas De Trabajo Con Gran Ahorro De Agua.

LUNA-TIMER-GRIGIA

8025431152953

MATERIALE ALLUMINIO
ESTRUSO AA 6063
MATERIAL EXTRUSION
ALUMINUM AA 6063

UGELLI ANTICALCARE
ANTISCALE NOZZLES

PESO 8 KG
WEIGHT 8 KG

INCLUDE UNA SACCA
DI PROTEZIONE
INCLUDES A
PROTECTION BAG



SINED IN ESCLUSIVA MONDIALE!
DOPPIO INGRESSO ACQUA
LATERALE O INFERIORE

SINED WORLD WIDE EXCLUSIVE!
DOUBLE WATER INLET
SIDE OR BOTTOM

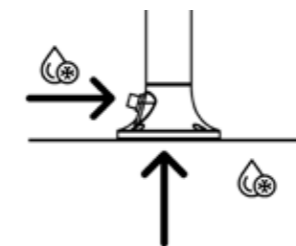

ACQUA FREDDA
COLD WATER



GETTO D'ACQUA
VERTICAL
WATER JET
VERTICAL



FUNZIONE TIMER
TIMER FUNCTION



(mm)

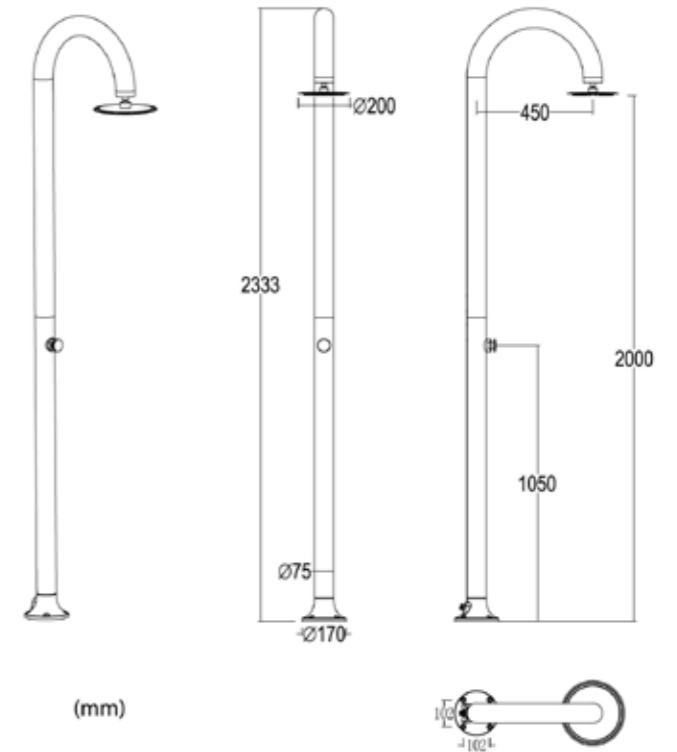

ACCESSORI ACCIAIO INOX 304
ACCESSORIES STAINLESS STEEL 304

FILTRO ANTICALCARE INCLUSO
FILTER LIMESCALE INCLUDED

VERNICIATURA A POLVERE
ELETTROSTATICA DI QUALITÀ
AUTOMOBILISTICA. AUTOMOTIVE QUALITY
ELECTROSTATIC POWDER COATING



PRODOTTO IN DUE
PARTI. SCATOLA FACILE DA
MANEGGIARE
PRODUCT IN TWO
PARTS EASY-TO-HANDLE
BOX

**IT**

Doccia Temporizzata In Alluminio Nero. Eroga Solo Acqua Fredda, Con Miscelatore Per La Regolazione Del Flusso. Attacco Doppio Dell'acqua, Sotto e a Lato. Per Interni Che Per Esterni Dell'abitazione. Ideale Per Uso Intensivo Con Grande Risparmio Idrico.

EN

Black Aluminium Timed Shower. Delivers Cold Water Only, with Flow Regulating Mixer. Dual Water Connection, Side and Bottom. For both indoor and outdoor use. Ideal For Intensive Use With Great Water Saving.

FR

Douche temporisée en aluminium noir. Fournit uniquement de l'eau froide, avec mitigeur régulateur de débit. Double raccordement à l'eau, latéral et par le bas. Pour une utilisation à l'intérieur et à l'extérieur. Idéale pour une utilisation intensive avec une grande économie d'eau.

DE

Zeitgesteuerte Dusche aus schwarzem Aluminium. Liefert nur kaltes Wasser, mit durchflussgeregeltem Mischer. Doppelter Wasseranschluss, seitlich und unten. Für den Innen- und Außenbereich geeignet. Ideal für intensive Nutzung mit großer Wassereinsparung.

ES

Ducha temporizada de aluminio negro. Suministra sólo agua fría, con mezclador regulador de caudal. Doble conexión de agua, lateral e inferior. Para uso interior y exterior. Ideal para uso intensivo con gran ahorro de agua.

LUNA-TIMER-NERA

8025431152946

MATERIALE ALLUMINIO
ESTRUSO AA 6063
MATERIAL EXTRUSION
ALUMINUM AA 6063

UGELLI ANTICALCARE
ANTISCALE NOZZLES

PESO 8 KG
WEIGHT 8 KG

INCLUDE UNA SACCA
DI PROTEZIONE
INCLUDES A
PROTECTION BAG



SINED IN ESCLUSIVA MONDIALE!
DOPPIO INGRESSO ACQUA
LATERALE O INFERIORE

SINED WORLD WIDE EXCLUSIVE!
DOUBLE WATER INLET
SIDE OR BOTTOM

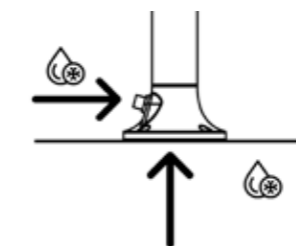

ACQUA FREDDA
COLD WATER



GETTO D'ACQUA
VERTICAL
WATER JET
VERTICAL



FUNZIONE TIMER
TIMER FUNCTION



(mm)

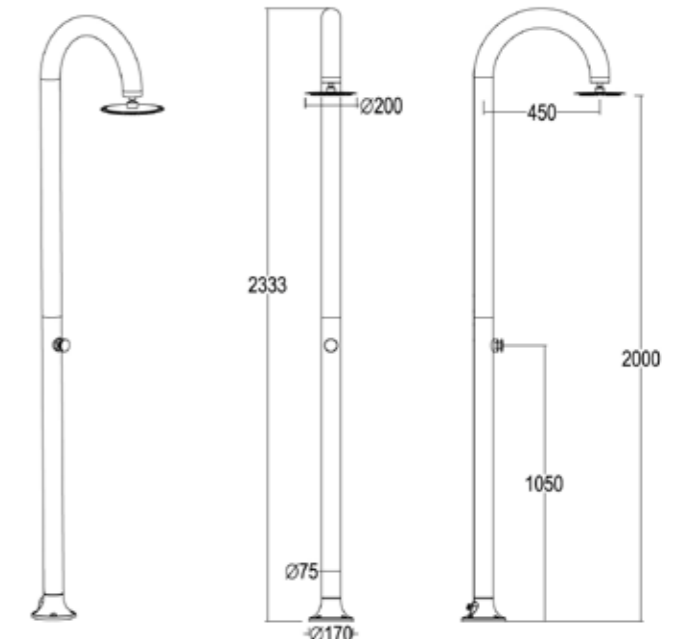

ACCESSORI ACCIAIO INOX 304
ACCESSORIES STAINLESS STEEL 304

FILTRO ANTICALCARE INCLUSO
FILTER LIMESCALE INCLUDED

VERNICIATURA A POLVERE
ELETTROSTATICA DI QUALITÀ
AUTOMOBILISTICA. **AUTOMOTIVE QUALITY**
ELECTROSTATIC POWDER COATING



PRODOTTO IN DUE
PARTI. **SCATOLA FACILE DA**
MANEGGIARE
PRODUCT IN TWO
PARTS **EASY-TO-HANDLE**
BOX

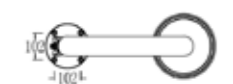

LUNA-TIMER-P-BIANCA

8025431152922

MATERIALE ALLUMINIO
ESTRUSO AA 6063
MATERIAL EXTRUSION
ALUMINUM AA 6063

UGELLI ANTICALCARE
ANTISCALE NOZZLES

PESO 8 KG
WEIGHT 8 KG

INCLUDE UNA SACCA
DI PROTEZIONE
INCLUDES A
PROTECTION BAG



SINED IN ESCLUSIVA MONDIALE!
DOBPIO INGRESSO ACQUA
LATERALE O INFERIORE

SINED WORLD WIDE EXCLUSIVE!
DOUBLE WATER INLET
SIDE OR BOTTOM

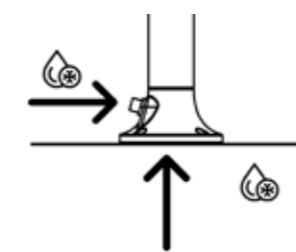

ACQUA FREDDA
COLD WATER



GETTO D'ACQUA
VERTICAL
WATER JET
VERTICAL



FUNZIONE TIMER
TIMER FUNCTION



ACCESSORI ACCIAIO INOX 304
ACCESSORIES STAINLESS STEEL 304

FILTRO ANTICALCARE INCLUSO
FILTER LIMESCALE INCLUDED

VERNICIATURA A POLVERE
ELETTROSTATICA DI QUALITÀ
AUTOMOBILISTICA. AUTOMOTIVE QUALITY
ELECTROSTATIC POWDER COATING

PRODOTTO IN DUE
PARTI. SCATOLA FACILE DA
MANEGGIARE
PRODUCT IN TWO
PARTS EASY-TO-HANDLE
BOX

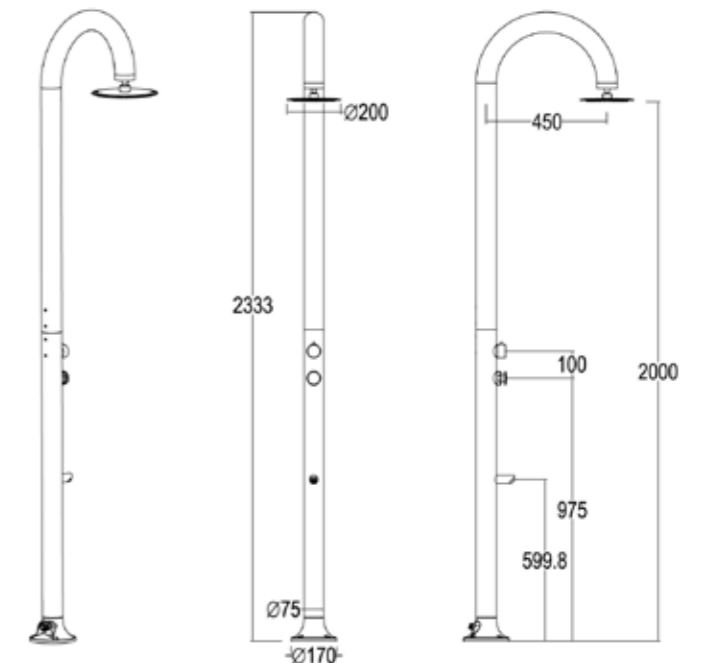

(mm)



IT

Doccia Temporizzata In Alluminio Bianca. Eroga Solo Acqua Fredda, Con Miscelatore Per La Regolazione Del Flusso e Lavapiedi. Attacco Doppio Dell'acqua, Sotto e a Lato. Per Interni Che Per Esterni. Ideale Per Uso Intensivo Con Grande Risparmio Idrico.

EN

White Aluminium Timed Shower. Supplies Cold Water Only, with Flow Regulating Mixer and Foot Wash. Dual Water Connection, Side and Bottom. For indoors and outdoors. Ideal For Intensive Use With Great Water Saving.

FR

Douche temporisée en aluminium blanc. Alimentation en eau froide uniquement, avec mitigeur régulateur de débit et lave-pieds. Double raccordement à l'eau, en dessous et sur le côté. Pour l'intérieur et l'extérieur. Idéale pour une utilisation intensive avec une grande économie d'eau.

DE

Zeitgesteuerte Dusche aus weißem Aluminium. Versorgt nur mit kaltem Wasser, mit Durchflussreguliermischer und Fußwaschanlage. Doppelter Wasseranschluss, unten und seitlich. Für drinnen und draußen. Ideal für intensiven Gebrauch mit großer Wasserersparnis.

ES

Ducha temporizada de aluminio blanco. Suministra sólo agua fría, con mezclador regulador de caudal y lavapiés. Doble conexión de agua, inferior y lateral. Para interior y exterior. Ideal para uso intensivo con gran ahorro de agua.

LUNA-TIMER-P-GRIGIA

8025431152960

MATERIALE ALLUMINIO
ESTRUSO AA 6063
MATERIAL EXTRUSION
ALUMINUM AA 6063

UGELLI ANTICALCARE
ANTISCALE NOZZLES

PESO 8 KG
WEIGHT 8 KG

INCLUDE UNA SACCA
DI PROTEZIONE
INCLUDES A
PROTECTION BAG



SINED IN ESCLUSIVA MONDIALE!
DOPPIO INGRESSO ACQUA
LATERALE O INFERIORE

SINED WORLD WIDE EXCLUSIVE!
DOUBLE WATER INLET
SIDE OR BOTTOM

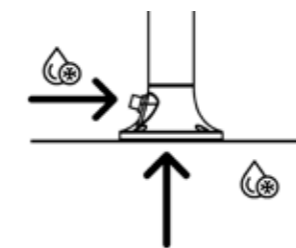

ACQUA FREDDA
COLD WATER



GETTO D'ACQUA
VERTICAL
WATER JET
VERTICAL



FUNZIONE TIMER
TIMER FUNCTION

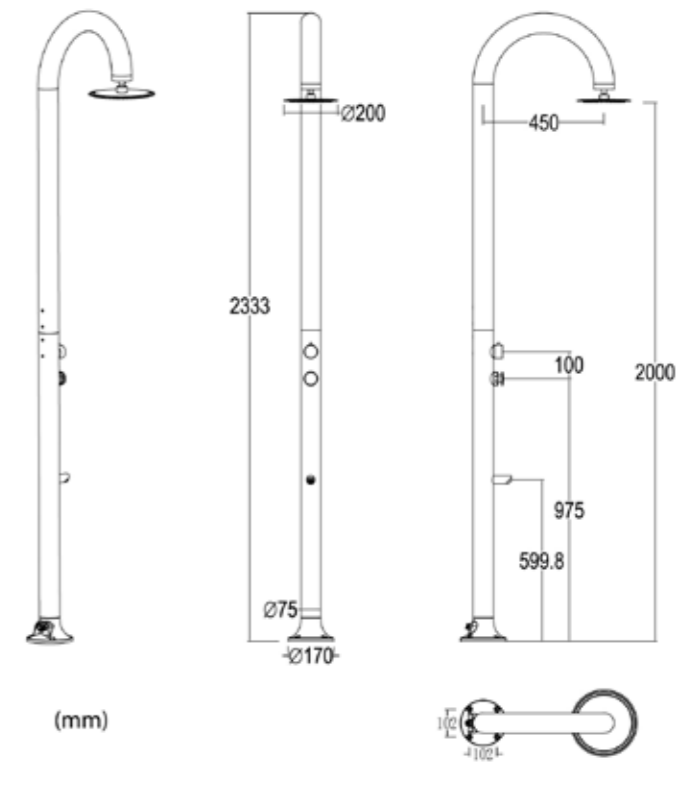

ACCESSORI ACCIAIO INOX 304
ACCESSORIES STAINLESS STEEL 304

FILTRO ANTICALCARE INCLUSO
FILTER LIMESCALE INCLUDED

VERNICIATURA A POLVERE
ELETTROSTATICA DI QUALITÀ
AUTOMOBILISTICA. AUTOMOTIVE QUALITY
ELECTROSTATIC POWDER COATING

PRODOTTO IN DUE
PARTI. SCATOLA FACILE DA
MANEGGIARE
PRODUCT IN TWO
PARTS EASY-TO-HANDLE
BOX

**IT**

Doccia Grigia In Alluminio Con Temporizzatore. Solo Acqua Fredda, Miscelatore Per Controllo Flusso e Funzione Lavapiedi. Doppio Ingresso Acqua, Basso e Laterale. Adatta Per Interni Che Esterni. Perfetta Per Un Uso Frequente, Garantisce Risparmio D'acqua.

EN

Grey Aluminium Shower With Timer. Cold Water Only, Flow Control Mixer and Foot Wash Function. Dual Water Inlet, Low and Side. Suitable For Indoor And Outdoor Use. Perfect For Frequent Use, Ensures Water Saving.

FR

Douche en aluminium gris avec minuterie. Eau froide uniquement, mitigeur de débit et fonction lave-pieds. Double arrivée d'eau, basse et latérale. Convient pour l'intérieur et l'extérieur. Parfaite pour un usage fréquent, elle permet d'économiser l'eau.

DE

Graue Aluminium-Dusche mit Zeitschaltuhr. Nur Kaltwasser, Mischer mit Durchflusskontrolle und Fußwaschfunktion. Doppelter Wasserzulauf, niedrig und seitlich. Für den Innen- und Außenbereich geeignet. Perfekt für häufigen Gebrauch, sorgt für Wassereinsparung.

ES

Ducha de aluminio gris con temporizador. Sólo agua fría, mezclador con control de caudal y función lavapiés. Doble entrada de agua, baja y lateral. Apta para uso interior y exterior. Perfecto para uso frecuente, garantiza el ahorro de agua.

LUNA-TIMER-P-NERA

8025431152939

MATERIALE ALLUMINIO
ESTRUSO AA 6063
MATERIAL EXTRUSION
ALUMINUM AA 6063

UGELLI ANTICALCARE
ANTISCALE NOZZLES

PESO 8 KG
WEIGHT 8 KG

INCLUDE UNA SACCA
DI PROTEZIONE
INCLUDES A
PROTECTION BAG



SINED IN ESCLUSIVA MONDIALE!
DOBPIO INGRESSO ACQUA
LATERALE O INFERIORE

SINED WORLD WIDE EXCLUSIVE!
DOUBLE WATER INLET
SIDE OR BOTTOM

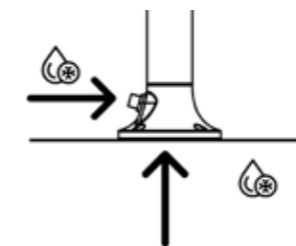

ACQUA FREDDA
COLD WATER



GETTO D'ACQUA
VERTICAL
WATER JET
VERTICAL



FUNZIONE TIMER
TIMER FUNCTION



(mm)

ACCESSORI ACCIAIO INOX 304
ACCESSORIES STAINLESS STEEL 304

FILTRO ANTICALCARE INCLUSO
FILTER LIMESCALE INCLUDED

VERNICIATURA A POLVERE
ELETTROSTATICA DI QUALITÀ
AUTOMOBILISTICA. AUTOMOTIVE QUALITY
ELECTROSTATIC POWDER COATING

PRODOTTO IN DUE
PARTI. SCATOLA FACILE DA
MANEGGIARE
PRODUCT IN TWO
PARTS EASY-TO-HANDLE
BOX

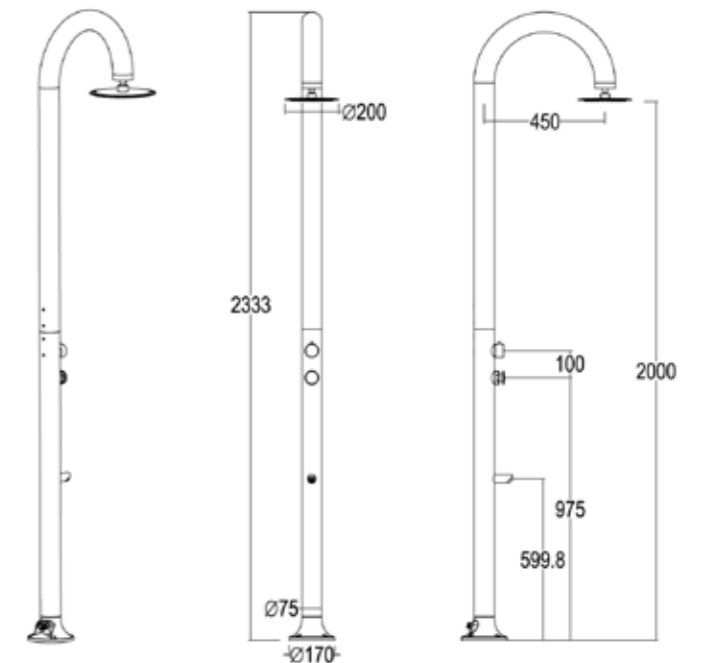
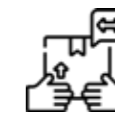

IT

Doccia Nera In Alluminio Con Temporizzatore. Solo Acqua Fredda, Miscelatore Per Controllo Flusso e Funzione Lavapiedi. Doppio Ingresso Acqua, Basso e Laterale. Adatta Per Interni Che Esterni. Perfetta Per Un Uso Frequente, Garantisce Risparmio D'acqua.

EN

Black Aluminium Shower With Timer. Cold Water Only, Flow Control Mixer and Foot Wash Function. Dual Water Inlet, Low and Side. Suitable For Indoor And Outdoor Use. Perfect For Frequent Use, Ensures Water Saving.

FR

Douche en aluminium noir avec minuterie. Eau froide uniquement, mitigeur de débit et fonction lave-pieds. Double arrivée d'eau, basse et latérale. Convient pour l'intérieur et l'extérieur. Parfaite pour un usage fréquent, elle permet d'économiser l'eau.

DE

Schwarze Aluminium-Dusche mit Zeitschaltuhr. Nur Kaltwasser, Mischer mit Durchflusskontrolle und Fußwaschfunktion. Doppelter Wasserzulauf, niedrig und seitlich. Für den Innen- und Außenbereich geeignet. Perfekt für häufigen Gebrauch, sorgt für Wassereinsparung.

ES

Ducha de aluminio negro con temporizador. Sólo agua fría, mezclador con control de caudal y función lavapiés. Doble entrada de agua, baja y lateral. Apta para uso interior y exterior. Perfecto para uso frecuente, garantiza el ahorro de agua.

LUNA-ALU

LCD / LED / SENSOR

SOFFIONI INTELLIGENTI SMART SHOWERHEADS

COLORI BIANCO, GRIGIO E NERO
COLORS WHITE, GREY AND BLACK



MATERIALE ESTRUSIONE DI
ALLUMINIO AA 6063
MATERIAL EXTRUSION ALUMINUM
AA 6063

UGELLI ANTICALCARE
ANTISCALE NOZZLES

PESO 8 KG
WEIGHT 8 KG

ACCESSORI ACCIAIO INOX 304
ACCESSORIES STAINLESS STEEL 304

DUE FILTRI ANTICALCARE INCLUSI
TWO ANTI-SCALE FILTERS INCLUDED

VERNICIATURA ELETTROSTATICA A POLVERE DI
QUALITÀ AUTOMOBILISTICA
AUTOMOTIVE QUALITY ELECTROSTATIC POWDER
COATING

INCLUDE UNA SACCA DI PROTEZIONE
INCLUDES A PROTECTION BAG

SOFFIONE PLASTICO ABS
ABS PLASTIC SHOWERHEAD

PRODOTTO IN DUE PARTI
SCATOLA FACILE DA MANEGGIARE (-120CM)
PRODUCT IN TWO-PARTS
EASY-TO-HANDLE BOX (-120CM)

SINED WORLD
WIDE EXCLUSIVE!

DOUBLE WATER INLET
SIDE OR BOTTOM

GETTO D'ACQUA
VERTICALE
WATER JET
VERTICAL



SINED ESCLUSIVA
MONDIALE!

DOPPIO INGRESSO ACQUA
LATERALE O INFERIORE

ACQUA
CALDA E FREDDA
WATER
HOT AND COLD



LCD



LED



SENSOR



LUNA-ALU-D

LCD / LED / SENSOR

SOFFIONI INTELLIGENTI SMART SHOWERHEADS

COLORI BIANCO, GRIGIO E NERO
COLORS WHITE, GREY AND BLACK



MATERIALE ESTRUSIONE DI
ALLUMINIO AA 6063
MATERIAL EXTRUSION
ALUMINUM AA 6063

UGELLI ANTICALCARE
ANTISCALE NOZZLES

PESO 8 KG
WEIGHT 8 KG

ACCESSORI ACCIAIO INOX 304
ACCESSORIES STAINLESS STEEL 304

DUE FILTRI ANTICALCARE INCLUSI
TWO ANTI-SCALE FILTERS INCLUDED

VERNICIATURA ELETTROSTATICA A POLVERE DI QUALITÀ
AUTOMOBILISTICA
AUTOMOTIVE QUALITY ELECTROSTATIC POWDER COATING

SOFFIONE PLASTICO ABS
ABS PLASTIC SHOWERHEAD

INCLUDE UNA SACCA DI PROTEZIONE
INCLUDES A PROTECTION BAG

DOCCINO FLESSIBILE
FLEXIBLE HANDSHOWER

PRODOTTO IN DUE PARTI
SCATOLA FACILE DA MANEGGIARE (-120CM)
PRODUCT IN TWO-PARTS
EASY-TO-HANDLE BOX (-120CM)

SINED WORLD
WIDE EXCLUSIVE!

DOUBLE WATER INLET
SIDE OR BOTTOM

GETTO D'ACQUA
VERTICALE
WATER JET
VERTICAL



SINED ESCLUSIVA
MONDIALE!

DOPPIO INGRESSO ACQUA
LATERALE O INFERIORE

ACQUA
CALDA E FREDDA
WATER
HOT AND COLD



LCD



LED



SENSOR



SOFFIONE DOCCIA-LED-3

SOFFIONI INTELLIGENTI SMART SHOWERHEADS

8025431152724

PESO 1.5 KG
WEIGHT 1.5 KG

MATERIALE PLASTICA ABS
MATERIAL ABS PLASTIC

UGELLI ANTICALCARE
ANTISCALE NOZZLES

GETTO D'ACQUA
VERTICALE
WATER JET
VERTICAL



ACQUA
CALDA E FREDDA
WATER
HOT AND COLD



IL COLOR DELLA LUCE LED CAMBIA IN BASE
ALLA TEMPERATURA REALE DELL'ACQUA
THE COLOUR OF THE LED LIGHT CHANGES
ACCORDING TO THE ACTUAL WATER



SISTEMA I-SWITCH. COMMUTAZIONE CON UN
GESTO. 3 MODALITÀ DI GETTO.
I-SWITCH SYSTEM. ONE-TOUCH SWITCHING.
3 WATER JET MODES.



IT

Soffione a Pioggia Rotondo
Diametro 240 Mm Soffione
Per Doccia Con Sensore
Ad Infrarossi e Luce
Led Diversa In Funzione
Della Temperatura Della
Acqua. Corpo In Abs e
Connettore In Ottone 3
Funzioni Del Getto Pioggia,
Nebulizzazione, Colonna
Acqua

Natural Rain
Optional Mist
Powerful LED



EN

Round Rain Shower Head
Diameter 240 Mm Shower
Head With Infrared Sensor
And Different Led Light
Depending On The Water
Temperature. Abs Body
And Brass Connector 3
Functions Of The Jet Rain,
Mist, Water Column

FR

Pomme De Douche Ronde
à Effet Pluie Diamètre 240
Mm Pomme De Douche
Avec Capteur Infrarouge Et
Lumière Led Qui Change En
Fonction De La Température
De L'eau. Corps En Abs
Et Connecteur En Laiton
3 Fonctions De Jet Pluie,
Brume, Colonne D'eau

DE

Runder Regenbrausekopf
Durchmesser 240
Mm Duschkopf Mit
Infrarotsensor Und
Led-licht, Das Sich Je
Nach Wassertemperatur
Ändert. Abs-gehäuse
Und Messinganschluss 3
Strahlfunktionen Regen,
Nebel, Wassersäule

ES

Alcachofa de Ducha
Redonda De 240 Mm
De Diámetro Ducha Con
Sensor De Infrarrojos
y Luz Led Que Cambia
Según La Temperatura
Del Agua. Cuerpo De
Abs y Conector De Latón
3 Funciones De Chorro
Lluvia, Niebla, Columna
De Agua

SOFFIONEDOCCIA-LED-4

SOFFIONI INTELLIGENTI SMART SHOWERHEADS

8025431017221

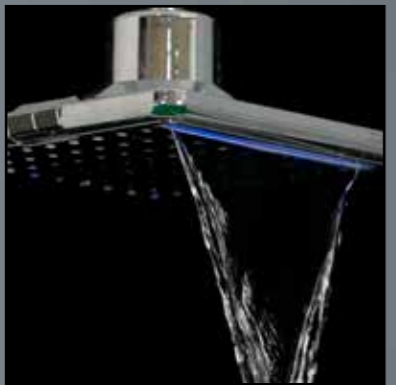

IT

Soffione Quadrato Per Doccia a Pioggia Sensore Ad Infrarossi e Luce Led Diversa In Funzione Della Temperatura Della Acqua. Corpo In Abs e Connettore In Ottone 2 Funzioni Del Getto Pioggia o Cascata Acqua Misure 20x20 Cm Funziona Con Il Solo Getto Acqua

EN

Square Rain Shower Head Infrared Sensor And Led Light Different According To The Water Temperature. Abs Body And Brass Connector 2 Functions Of The Jet Rain Or Waterfall Size 20x20 Cm Works With The Water Jet Only

FR

Pomme De Douche Carrée à Effet Pluie Capteur Infrarouge Et Lumière Led Qui Change En Fonction De La Température De L'eau. Corps En Abs Et Connecteur En Laiton 2 Fonctions Du Jet Pluie Ou Cascade Taille 20x20 Cm Fonctionne Uniquement Avec Le Jet D'eau

DE

Quadratischer Regenbrausekopf Mit Infrarotsensor Und Led-licht, Das Sich Je Nach Wassertemperatur Ändert. Abs-körper Und Messinganschluss 2 Funktionen Des Strahls Regen Oder Wasserfall Größe 20x20 Cm Funktioniert Nur Mit Dem Wasserstrahl

ES

Alcachofa de ducha De Lluvia Cuadrada Sensor Infrarrojo y Luz Led Que Cambia Según La Temperatura Del Agua. Cuerpo De Abs y Conector De Latón 2 Funciones Del Chorro Lluvia o Cascada Tamaño 20x20 Cm Funciona Sólo Con El Chorro De Agua

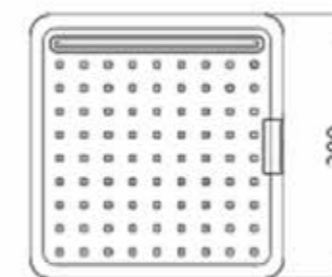

PESO 1.5 KG
WEIGHT 1.5 KG

MATERIALE PLASTICA ABS
MATERIAL ABS PLASTIC

UGELLI ANTICALCARE
ANTISCALE NOZZLES



GETTO D'ACQUA
VERTICALE
WATER JET
VERTICAL



ACQUA
CALDA E FREDDA
WATER
HOT AND COLD

SISTEMA I-SWITCH. COMMUTAZIONE CON UN GESTO. 2 MODALITÀ DI GETTO.
I-SWITCH SYSTEM. ONE-TOUCH SWITCHING.
2 WATER JET MODES.



SOFFIONEDOCCIA-LED-5

SOFFIONI INTELLIGENTI SMART SHOWERHEADS

8025431017238



IT

Soffione a Pioggia Per Doccia Sensore a Infrarossi Con Funzione Cambio Del Getto Dell'acquadella Acqua. Senza Batteria Funziona Con Il Solo Getto Acqua. Corpo In Abs 22x22 Cm e Connettore In Ottone 3 Funzioni Del Getto Pioggia, Nebulizzazione e Cascata.

Rain Water Powerful Temp. & Timing
Fall Mist



EN

Rain Shower Head Infrared Sensor With Water Jet Change Function. Without Battery It Works With Water Jet Only. Abs Body 22x22 Cm And Brass Connector 3 Functions Of The Water Jet Rain, Mist, Waterfall.

FR

Pomme de douche à effet pluie Capteur infrarouge avec fonction de changement de jet d'eau. Sans batterie, il fonctionne uniquement avec un jet d'eau. Corps en ABS 22x22 cm et connecteur en laiton 3 fonctions de pulvérisation : pluie, brume, chute d'eau.

DE

Regenbrause Infrarotsensor Mit Wasserstrahlwechselfunktion. Ohne Batterie Arbeitet Er Nur Mit Wasserstrahl. Abs-körper 22x22 Cm Und Messinganschluss 3 Sprühfunktionen Regen, Nebel, Wasserfall, Wasserfall, Wasserfall.

ES

Alcachofa de Ducha Efecto Lluvia Sensor Infrarrojo Con Función De Cambio De Chorro De Agua. Sin Batería Funciona Sólo Con Chorro De Agua. Cuerpo De Abs De 22x22 Cm y Conector De Latón 3 Funciones De Rociado Lluvia, Niebla, Cascada, Cascada.

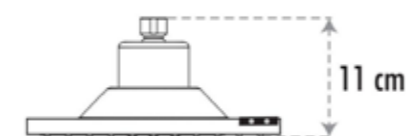
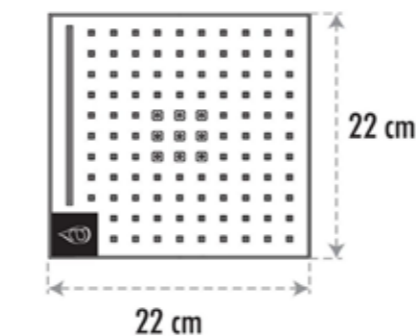

PESO 1.5 KG
WEIGHT 1.5 KG

MATERIALE PLASTICA ABS
MATERIAL ABS PLASTIC

UGELLI ANTICALCARE
ANTISCALE NOZZLES



GETTO D'ACQUA
VERTICALE
WATER JET
VERTICAL



ACQUA
CALDA E FREDDA
WATER
HOT AND COLD

DISPLAY LCD. VISUALIZZAZIONE DELLA
TEMPERATURA E DEL TEMPO DI UTILIZZO.
LCD DISPLAY. TEMPERATURE AND
TIME-OF-USE DISPLAY.



SISTEMA I-SWITCH. COMMUTAZIONE CON UN
GESTO. 3 MODALITÀ DI GETTO.
I-SWITCH SYSTEM. ONE-TOUCH SWITCHING.
3 WATER JET MODES.



DOCCE SOLE SUN SHOWERS

Le docce solari SINED sono progettate per offrire un'esperienza di doccia all'aperto sostenibile e confortevole. Queste docce, realizzate in alluminio o polietilene di alta qualità, riflettono l'eccellenza del design italiano, noto per la sua eleganza e funzionalità. Con una capacità del serbatoio fino a 40 litri, queste docce consentono di riscaldare l'acqua utilizzando l'energia solare, offrendo così una soluzione ecologica ed economica per l'uso quotidiano all'aperto.

Il design italiano di queste docce solari non solo aggiunge un tocco di raffinatezza a qualsiasi giardino o area piscina, ma garantisce anche la massima durata e resistenza alle condizioni atmosferiche avverse. Oltre alla loro struttura robusta, le docce solari SINED sono dotate di una serie di accessori progettati per prolungarne la durata e migliorare l'esperienza dell'utente. Questi accessori includono ugelli anticalcare, accessori in ottone black matt e tubi interni in

Il sistema di riscaldamento solare è un altro punto di forza di queste docce. Grazie a questo sistema, l'acqua immagazzinata nel serbatoio viene riscaldata in modo efficiente utilizzando esclusivamente l'energia del sole, il che non solo riduce il consumo energetico, ma contribuisce anche a proteggere l'ambiente. Questo metodo ecologico garantisce di avere sempre a disposizione

Le docce solari SINED combinano tecnologia avanzata, design sofisticato e una forte consapevolezza ecologica, rappresentando la scelta ideale per chi desidera migliorare i propri spazi esterni in modo sostenibile ed economico.

SINED solar showers are designed to provide a sustainable and comfortable outdoor showering experience. These showers, made of high-quality aluminium or polyethylene, reflect the excellence of Italian design, known for its elegance and functionality. With a tank capacity of up to 40 litres, these showers allow water to be heated using solar energy, offering an environmentally friendly and economical solution for everyday outdoor use.

The Italian design of these solar showers not only adds a touch of sophistication to any garden or pool area, but also guarantees maximum durability and resistance to adverse weather conditions. In addition to their robust construction, SINED solar showers come with a range of accessories designed to prolong their lifespan and enhance the user experience. These accessories include anti-limescale nozzles, black matt brass fittings and internal steel hoses up to 15 kg pressure.

The solar heating system is another highlight of these showers. Thanks to this system, the water stored in the tank is heated efficiently using only the sun's energy, which not only reduces energy consumption, but also helps to protect the environment. This environmentally friendly method ensures that hot water is always available at no extra cost.

SINED solar showers combine advanced technology, sophisticated design and a strong ecological awareness, making them the ideal choice for those who wish to improve their outdoor spaces in a sustainable and economical way.



DOCCIA-SOLE-NERA

8025431017023



GRIGIA

S025431017016



VERDE

S025431017504



BIANCA

S025431017009



ROSSA

S025431017139



BLU

S025431017122

MATERIALE POLIETILENE HD
MATERIAL POLYETHYLENE HD

UGELLI ANTICALCARE
ANTISCALE NOZZLES

INCLUDE UNA SACCA
DI PROTEZIONE
INCLUDES A PROTECTION
BAG



TAPPO DI DRENAGGIO
DRAINING PLUG



TASSELLI, VITI E BOCCOLE IN
NYLON RINFORZATO PER UN
MIGLIORE FISSAGGIO AL SUOLO
DOWELS, SCREWS AND BRUSHES
MADE OF REINFORCED NYLON FOR
BETTER FASTENING TO THE GROUND

COLLEGAMENTO ALL'AC-QUA IN UN
SOLO TUBO
CONNECTION TO WATER IN ONLY 1
PIPE

VALVOLA DI INTERCETTA-ZIONE
DELL'ACQUA
VALVE WATER SHUT-OFF

COLLEGAMENTO ACQUA LATERALE 1/2
SIDE WATER CONNECTION

LITRI 22L
LITER 22L

COLORE
COLOUR

PESO 8.5 KG
WEIGHT 8,5 KG

BLU RAL 5012
BIANCO RAL 9003
NERA RAL 9017
ROSSO RAL 3018
GRIGIO RAL 7037
VERDE

ACCESSORI IN OTTONE BLACK MATT
ACCESSORIES MADE OF BRASS

FILTRO ANTICALCARE ESTERNO INCLUSO
EXTERNAL ANTI-SCALE FILTER INCLUDED



DOCCIA RISCALDAMENTO SOLARE
SOLAR HEATING SHOWER

CAPACITÀ DEL SERBATORIO 25L
TANK CAPACITY 25L

TUBI INTERNI IN ACCIAIO FINO A 12
KG DI PRESSIONE
BRAIDED STEEL INNER HOSE UP TO
12 KG PRESSURE

IL DOPPIO DELLO SPES-SORE. PIÙ
RESISTENTE
TWICE AS THICK. MORE RESISTANT

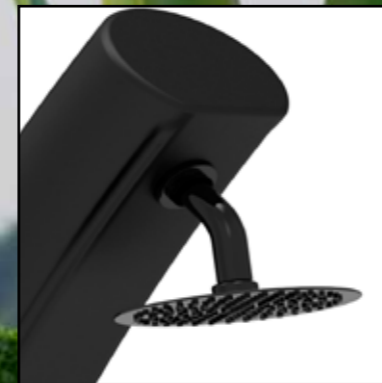
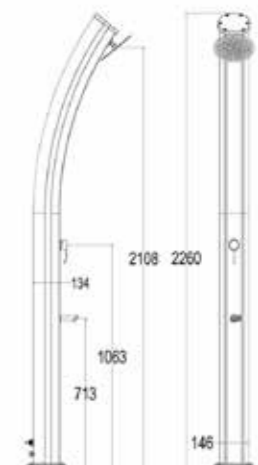
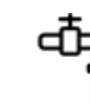

IT

Doccia solare bianca con struttura curva in polietilene Hd, modello Sun. Per giardino e piscina Altezza 226 cm Soffione rotondo Diametro 15,24 cm Serbatoio 25 litri Con lavapiedi Accessori e rubinetteria in metallo nero Con filtro anticalcare Copridoccia.

EN

White Solar Shower With Curved Hd Polyethylene Structure, Sun Model. For Garden And Pool Height 226 Cm Round Shower Head Diameter 15.24 Cm Tank 25 Liters With Foot Washers Black Metal Accessories And Faucets With Anti-limescale Filter Shower Cover.

FR

Douche solaire blanche avec structure courbe en polyéthylène haute densité, modèle solaire. Pour Jardin et Piscine Hauteur 226 Cm Pomme de Douche Ronde Diamètre 15.24 Cm Réservoir 25 Litres Avec Rondelles de Pieds Accessoires et Robinetterie en Métal Noir Avec Filtre Anti-calcaire Couvre

DE

Weißer Solardusche mit gebogener Hd Polyethylen-Struktur, einziges Modell. Für Garten und Pool Höhe 226 Cm Runde Duschkopf Durchmesser 15,24 Cm Tank 25 Liter mit Fuß Waschmaschine Schwarz Metall Zubehör und Armaturen mit Anti-Kalk-Filter Duscabdeckung.

ES

Ducha Solar Blanca Con Estructura Curvada De Polietileno Hd, Modelo Único. Para Jardín y Piscina Altura 226 Cm Ducha Redonda Diámetro 15,24 Cm Depósito 25 Litros Con Lavapiés Accesorios y Grifería Metal Negro Con Filtro Antical Cubierta Ducha

DOCCIA-SOLE-XXL-NERA

8025431017177



GRIGIA

S025431017160



BIANCA

S025431017146



VERDE

S025431017528



ROSSA

S025431017184



BLU

S025431017153

MATERIALE POLIETILENE HD
MATERIAL POLYETHYLENE HD

UGELLI ANTICALCARE
ANTISCALE NOZZLES

INCLUDE UNA SACCA
DI PROTEZIONE
INCLUDES A PROTECTION
BAG



TAPPO DI DRENAGGIO
DRAINING PLUG



TASSELLI, VITI E BOCCOLE IN
NYLON RINFORZATO PER UN
MIGLIORE FISSAGGIO AL SUOLO
DOWELS, SCREWS AND BRUSHES
MADE OF REINFORCED NYLON FOR
BETTER FASTENING TO THE GROUND

COLLEGAMENTO ALL'ACQUA IN UN
SOLO TUBO
CONNECTION TO WATER IN ONLY 1
PIPE

VALVOLA DI INTERCETTA-ZIONE
DELL'ACQUA
VALVE WATER SHUT-OFF

COLLEGAMENTO ACQUA LATERALE 1/2
SIDE WATER CONNECTION

LITRI 40L
LITER 40L

COLORE
COLOUR

PESO 13.5 KG
WEIGHT 13,5 KG

BLU RAL 5012
BIANCO RAL 9003
NERA RAL 9017
ROSSO RAL 3018
GRIGIO RAL 7037
VERDE

ACCESSORI IN OTTONE BLACK MATT
ACCESSORIES MADE OF BRASS

FILTRO ANTICALCARE ESTERNO INCLUSO
EXTERNAL ANTI-SCALE FILTER INCLUDED



DOCCIA RISCALDAMENTO SOLARE
SOLAR HEATING SHOWER

CAPACITÀ DEL SERBATORIO 25L
TANK CAPACITY 25L

TUBI INTERNI IN ACCIAIO FINO A 12
KG DI PRESSIONE
BRAIDED STEEL INNER HOSE UP TO
12 KG PRESSURE

IL DOPPIO DELLO SPES-SORE. PIÙ
RESISTENTE
TWICE AS THICK. MORE RESISTANT

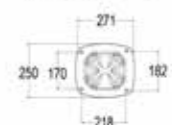
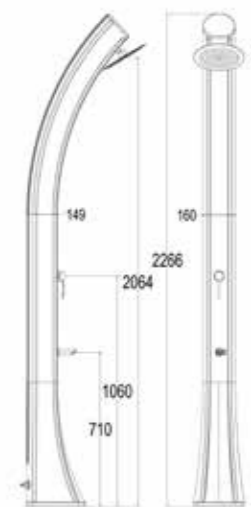

IT

Doccia solare Nera ral 9017 per giardino Doccia con Soffione rotondo diametro 20 cm Serbatoio 40 Litri Rubinetto Lavapiedi Altezza 226,6 cm Struttura Curva in Polietilene HD con Accessori in ottone nero black matt. In regalo filtro anticalcare e copertura.

EN

Solar Shower Black ral 9017 for garden Shower with round Shower head diameter 20 cm Tank 40 Litres Footwash tap Height 226,6 cm Curved structure in HD Polyethylene with accessories in black matt brass. In gift limescale filter and cover.

FR

Douche Solaire Black ral 9017 pour jardin Douche avec pommeau de douche rond diamètre 20 cm Réservoir 40 Litres Robinet lave-pieds Hauteur 226,6 cm Structure courbe en Polyéthylène HD avec accessoires en laiton noir mat. En cadeau, filtre anticalcaire et couvercle.

DE

Solardusche Schwarz ral 9017 für Garten Dusche mit rundem Duschkopf Durchmesser 20 cm Tank 40 Liter Fußwaschhahn Höhe 226,6 cm Gebogene Struktur in HD Polyethylen mit Zubehör in schwarzem mattem Messing. In Geschenk Kalkfilter und Abdeckung.

ES

Ducha Solar Negra ral 9017 para jardín Ducha con rociador redondo Diámetro del rociador 20 cm Depósito 40 Litros Grifo lavapiés Altura 226,6 cm Estructura curvada en Polietileno HD con accesorios en latón negro mate. De regalo filtro antical y tapa.

DOCCIA-SOLE-XXL-NERA-ORO

8025431017177



IT

Doccia solare Nera ral 9017 per giardino Doccia con Soffione rotondo diametro 20 cm Serbatoio 40 Litri Rubinetto Lavapiedi Altezza 226,6 cm Struttura Curva in Polietilene HD con Accessori in ottone nero black matt. In regalo filtro anticalcare e copertura.

EN

Solar Shower Black For Garden Shower With Round Shower Head Diameter 20 Cm Tank 40 Liters Foot Wash Tap Height 226,6 Cm Curved Structure In Hd Polyethylene With Metal Accessories Balck Matt. Limestone Filter And Cover For The Shower, Included.

FR

Douche Solaire Noire Pour Jardin Douche Avec Pommeau De Douche Rond Diamètre 20 Cm Réservoir 40 Litres Rince-pieds Hauteur 226,6 Cm Structure Courbeée En Polyéthylène Hd Avec Accessoires Black Matt. Filtre Anticalcaire Et Sac De Protection, Inclus.

DE

Solardusche Schwarz ral 9017 für Garten Dusche mit rundem Duschkopf Durchmesser 20 cm Tank 40 Liter Fußwaschhahn Höhe 226,6 cm Gebogene Struktur in HD Polyethylen mit Zubehör in schwarzem matten Messing. Im Geschenk Kalkfilter und Abdeckung.

ES

Ducha Solar Negra ral 9017 para jardín Ducha con rociador redondo Diámetro de la ducha 20 cm Depósito 40 Litros Grifo lavapiés Altura 226,6 cm Estructura curvada en Polietileno HD con accesorios en latón negro mate. De regalo filtro antical y tapa.



MATERIALE POLIETILENE HD
MATERIAL POLYETHYLENE HD

UGELLI ANTICALCARE
ANTISCALE NOZZLES

INCLUDE UNA SACCA
DI PROTEZIONE
INCLUDES A PROTECTION
BAG



TAPPO DI DRENAGGIO
DRAINING PLUG



TASSELLI, VITI E BOCCOLE IN
NYLON RINFORZATO PER UN
MIGLIORE FISSAGGIO AL SUOLO
DOWELS, SCREWS AND BRUSHES
MADE OF REINFORCED NYLON FOR
BETTER FASTENING TO THE GROUND

COLLEGAMENTO ALL'ACQUA IN UN
SOLO TUBO
CONNECTION TO WATER IN ONLY 1
PIPE

VALVOLA DI INTERCETTA-ZIONE
DELL'ACQUA
VALVE WATER SHUT-OFF



COLLEGAMENTO ACQUA LATERALE 1/2
SIDE WATER CONNECTION



LITRI 40L
LITER 40L

COLORE
COLOUR

PESO 13.5 KG
WEIGHT 13,5 KG

BLU RAL 5012
BIANCO RAL 9003
NERA RAL 9017
ROSSO RAL 3018
GRIGIO RAL 7037
VERDE

ACCESSORI IN OTTONE BLACK MATT
ACCESSORIES MADE OF BRASS

FILTRO ANTICALCARE ESTERNO INCLUSO
EXTERNAL ANTI-SCALE FILTER INCLUDED



DOCCIA RISCALDAMENTO SOLARE
SOLAR HEATING SHOWER

CAPACITÀ DEL SERBATORIO 25L
TANK CAPACITY 25L

TUBI INTERNI IN ACCIAIO FINO A 12
KG DI PRESSIONE
BRAIDED STEEL INNER HOSE UP TO
12 KG PRESSURE

IL DOPPIO DELLO SPES-SORE. PIÙ
RESISTENTE
TWICE AS THICK. MORE RESISTANT

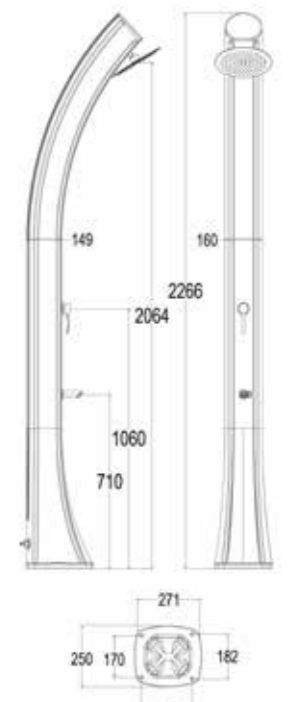

DOCCIA-DINO-NERA

8025431017245

MATERIALE ALLUMINIO
MATERIAL ALUMINIUM

UGELLI ANTICALCARE
ANTISCALE NOZZLES

PESO 15 KG
WEIGHT 15 KG

INCLUDE UNA SACCA
DI PROTEZIONE
INCLUDES A PROTEC-
TION BAG



TAPPO DI DRENAGGIO
DRAINING PLUG



TASSELLI, VITI E BOCCOLE IN
NYLON RINFORZATO PER UN
MIGLIORE FISSAGGIO AL SUOLO
DOWELS, SCREWS AND BRUSHES
MADE OF REINFORCED NYLON FOR
BETTER FASTENING TO THE GROUND

COLLEGAMENTO ALL'ACQUA IN UN
SOLO TUBO
CONNECTION TO WATER IN ONLY 1
PIPE



VALVOLA DI INTERCETTAZIONE
DELL'ACQUA
VALVE WATER SHUT-OFF



COLLEGAMENTO ACQUA LATERALE 1/2
SIDE WATER CONNECTION



LITRI 26L
LITER 26L

COLORE NERO RAL 9004
COLOUR

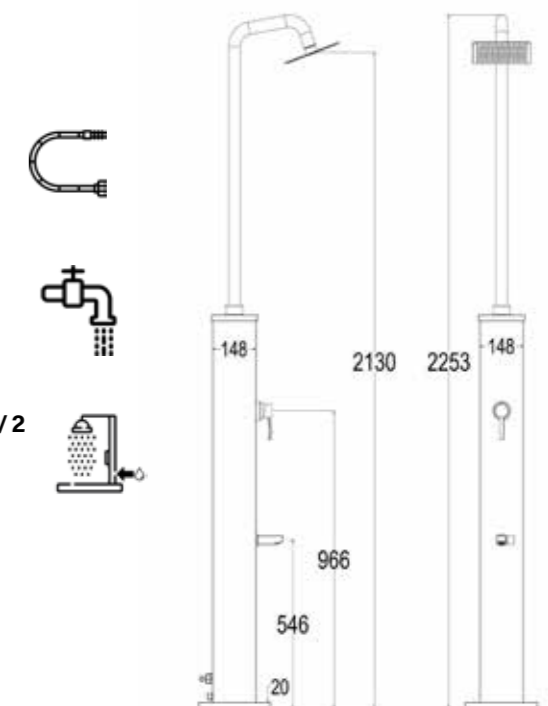

ACCESSORI IN OTTONE BLACK MATT
ACCESSORIES MADE OF BRASS

FILTRO ANTICALCARE ESTERNO INCLUSO
EXTERNAL ANTI-SCALE FILTER INCLUDED



DOCCIA RISCALDAMENTO SOLARE
SOLAR HEATING SHOWER

TUBI INTERNI IN ACCIAIO FINO A 15
KG DI PRESSIONE
BRAIDED STEEL INNER HOSE UP TO
15 KG PRESSURE

CAPACITÀ DEL SERBATORIO 26L
TANK CAPACITY 26L

IL DOPPIO DELLO SPES-SORE. PIÙ
RESISTENTE
TWICE AS THICK. MORE RESISTANT

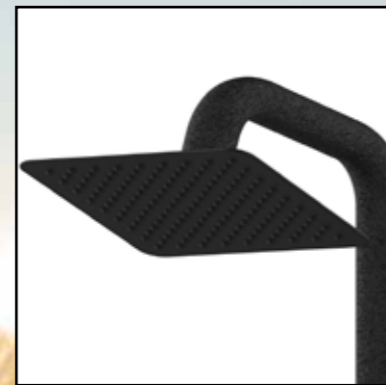

IT

Doccia Solare Dino Nera
Doccia Calda Da Esterno
Riscaldata Dal Sole In
Alluminio Serbatoio 26
Litri Soffione Quadrato 22
Cm In Abs e Miscelatore,
Lavapiedi. Altezza 225 Cm
Pressione Max. Di Esercizio
3 Bar.

EN

Dino Solar Shower Black
Outdoor Hot Shower
Heated By The Sun In
Aluminium Tank 26 Liters
Square Shower Head 22
Cm In Abs And Mixer, Foot
Wash. Height 225 Cm Max
Working Pressure 3 Bar.

FR

Dino Solar Shower Black
Douche D'extérieur
Chauffée Par Le Soleil En
Aluminium. Réservoir De 26
Litres Pommeau De Douche
Carrée De 22 Cm En Abs,
Mitigeur, Rince-pieds.
Hauteur 225 Cm Pression
De Travail 3 Bar Max.

DE

Solar Dusche Dino
Schwarz Warme Von
Der Sonne Beheizte
Außendusche, Die Von
Der Sonne Beheizt Wird,
Mit 26 Liter Wassertank,
Quadratischem Duschkopf
22 Cm Aus Abs, Mischer
Und Fußwaschhahn Höhe
225 Cm Arbeitsdruck Max.
3 Bar.

ES

Dino Ducha Solar Negra
De Exterior Caliente
Calentada Por El Sol
Con Base De Aluminio y
Tubo Superior Curvado
En Acero Inoxidable
Depósito 26 Litros Ducha
Cuadrada De 22 Cm En
Abs y Mezclador, Lavapiés.
Altura 225 Cm Presión
Máxima De Trabajo 3 Bar.

**IT**

Doccia Ecologica Solare Dafne Blu Con Soffione Rotondo Da 20 Cm Miscelatore e Rubinetto Lavapiedi Doccia Con Struttura Curva In Alluminio Per Esterno Serbatoio 35 Litri Altezza 226 Cm. Indicata Per Bordo Piscina, Giardino, Beb, Hotels, Campeggi.

EN

Dafne Blue Ecological Solar Shower With 20 Cm Round Shower Head, Mixer And Foot Wash Tap Shower With Curved Aluminium Structure For Outdoor Use. 35 Litre Tank, 220 Cm High. Suitable For Swimming Pool, Garden, Beb, Hotels, Campings.

FR

Dafne Bleu Douche Solaire Écologique Avec Pomme De Douche Ronde De 20 Cm, Mitigeur Et Rince-pieds.avec Structure En Aluminium Courbé Pour L'extérieur. Réservoir De 35 Litres, Hauteur 220 Cm. Convient Pour La Piscine, Le Jardin, Les Beb, Hôtels, Campings.

DE

Umweltfreundliche Solardusche Dafne Dunkelblau Mit 20 Cm Rundem Duschkopf, Mischbatterie Und Fußwaschhahn Bogenförmige Aluminium-dusche Für Den Außenbereich. 35 Liter Tank, 220 Cm Hoch. Geeignet Für Schwimmbad,

ES

Ducha Solar Ecológica Dafne Blue Con Rociador Redondo De 20 Cm, Mezclador y Grifo De Pie Ducha Con Estructura De Aluminio Curvada Para Uso Exterior. Depósito De 35 Litros, 220 Cm De Altura. Apto Para Piscina, Jardín, Beb, Hoteles, Campings.

**DOCCIA-DAFNE****DOCCIA-DAFNE-BLU**

8025431017269

MATERIALE ALLUMINIO
MATERIAL ALUMINIUM

UGELLI ANTICALCARE
ANTISCALE NOZZLES

PESO 12,5 KG
WEIGHT 12,5 KG

INCLUDE UNA SACCA
DI PROTEZIONE
INCLUDES A PROTEC-
TION BAG



TAPPO DI DRENAGGIO
DRAINING PLUG



TASSELLI, VITI E BOCCOLE IN
NYLON RINFORZATO PER UN
MIGLIORE FISSAGGIO AL SUOLO
DOWELS, SCREWS AND BRUSHES
MADE OF REINFORCED NYLON FOR
BETTER FASTENING TO THE GROUND

COLLEGAMENTO ALL'ACQUA IN UN
SOLO TUBO
CONNECTION TO WATER IN ONLY 1
PIPE

VALVOLA DI INTERCETTA-ZIONE
DELL'ACQUA
VALVE WATER SHUT-OFF

COLLEGAMENTO ACQUA LATERALE 1/2
SIDE WATER CONNECTION

LITRI 35L
LITER 35L

COLORE BLU RAL 5002
COLOUR BIANCO RAL 9003
NERO RAL 9004



BIANCA
8025431017252



NERA
8025431017276

ACCESSORI IN OTTONE BLACK MATT
ACCESSORIES MADE OF BRASS

FILTRO ANTICALCARE ESTERNO INCLUSO
EXTERNAL ANTI-SCALE FILTER INCLUDED



DOCCIA RISCALDAMENTO SOLARE
SOLAR HEATING SHOWER

TUBI INTERNI IN ACCIAIO FINO A 15
KG DI PRESSIONE
BRAIDED STEEL INNER HOSE UP TO
15 KG PRESSURE

CAPACITÀ DEL SERBATORIO 26L
TANK CAPACITY 26L

IL DOPPIO DELLO SPES-SORE. PIÙ
RESISTENTE
TWICE AS THICK. MORE RESISTANT

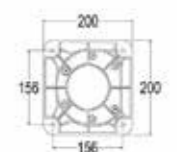
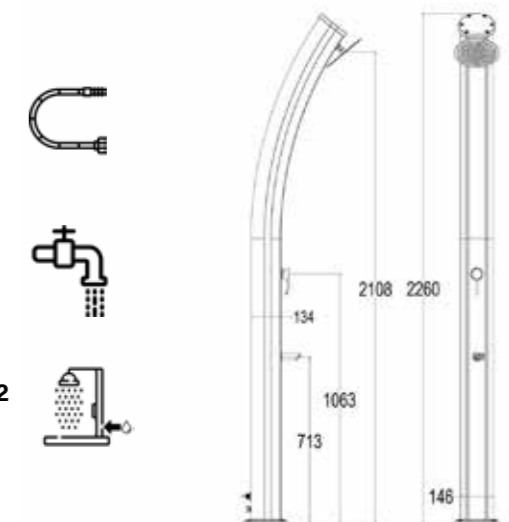

DOCCIA-ELLA

DOCCIA-ELLA-GRIGIA-WOOD

8025431016910



MATERIALE ALLUMINIO
MATERIAL ALUMINIUM

ACCESSORI IN OTTONE BLACK MATT
ACCESSORIES MADE OF BRASS

UGELLI ANTICALCARE
ANTISCALE NOZZLES

FILTRO ANTICALCARE ESTERNO INCLUSO
EXTERNAL ANTI-SCALE FILTER INCLUDED

PESO 17,5 KG
WEIGHT 17,5 KG



DOCCIA RISCALDAMENTO SOLARE
SOLAR HEATING SHOWER

INCLUDE UNA SACCA
DI PROTEZIONE
INCLUDES A PROTEC-
TION BAG



TUBI INTERNI IN ACCIAIO FINO A 15
KG DI PRESSIONE
BRAIDED STEEL INNER HOSE UP TO
15 KG PRESSURE

TAPPO DI DRENAGGIO
DRAINING PLUG



CAPACITÀ DEL SERBATORIO 26L
TANK CAPACITY 26L

TASSELLI, VITI E BOCCOLE IN
NYLON RINFORZATO PER UN
MIGLIORE FISSAGGIO AL SUOLO
DOWELS, SCREWS AND BRUSHES
MADE OF REINFORCED NYLON FOR
BETTER FASTENING TO THE GROUND

IL DOPPIO DELLO SPES-SORE. PIÙ
RESISTENTE
TWICE AS THICK. MORE RESISTANT

COLLEGAMENTO ALL'AC-QUA IN UN
SOLO TUBO
CONNECTION TO WATER IN ONLY 1
PIPE



VALVOLA DI INTERCETTA-ZIONE
DELL'ACQUA
VALVE WATER SHUT-OFF



COLLEGAMENTO ACQUA LATERALE 1/2
SIDE WATER CONNECTION



LITRI 40L
LITER 40L

COLORE GRIGIO RAL 7048 + WOOD 001
COLOUR NERA RAL 9004 + NN7851-4

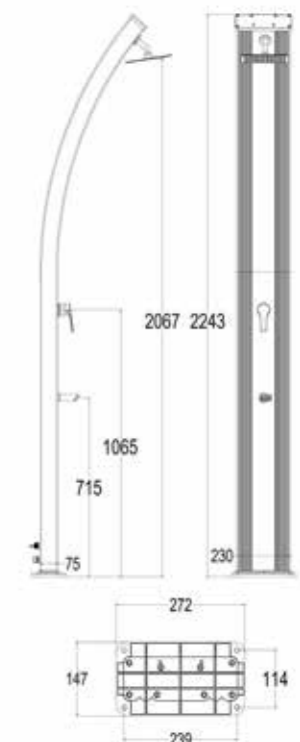

IT

Elegante Doccia Solare
In Alluminio Ella Colore
Grigio Con Fascia Centrale
Colore Legno Doccia Da
Giardino e Piscina Scoperta
Con Miscelatore Soffione
Quadrato e Rubinetto
Lavapiedi Struttura In
Alluminio Serbatoio 40 Litri
Altezza 224 Cm.

EN

Elegant Solar Shower In
Aluminium Ella Grey Colour
With Central Strip Wood
Colour Garden And Outdoor
Swimming Pool Shower
With Mixer Square Shower
Head And Foot Wash Tap
Aluminium Structure 40
Litres Tank Height 224 Cm.

FR

Elégante Douche Solaire
En Aluminium Ella
Couleur Gris Avec Bande
Centrale Couleur Bois
Douche De Jardin Et De
Piscine Extérieure Avec
Mitigeur Pommeau De
Douche Carrée Et Robinet
Rince-pieds Structure En
Aluminium Réservoir De 40
Litres Hauteur 224 Cm.

DE

Elegante Solardusche
Aus Aluminium Ella Farbe
Grau Mit Dekorstreifen
In Holzoptik Garten-
Und Pooldusche
Mit Mischbatterie
Quadratischer Duschkopf
Und Fußwaschhahn
Aluminiumstruktur 40-liter-
tank Höhe 224 Cm.

ES

Elegante Ducha Solar
De Aluminio Color Gris
Ella Con Franja Central
Color Madera Ducha De
Jardín y Piscina Exterior
Con Mezclador Ducha
Cuadrada y Grifo Lavapiés
Estructura De Aluminio
Depósito De 40 Litros
Altura 224 Cm.

DOCCIA-EMI**DOCCIA-EMI-BLU**

8025431016934



BIANCA
8025431017375

MATERIALE ALLUMINIO
MATERIAL ALUMINIUM

UGELLI ANTICALCARE
ANTISCALE NOZZLES

PESO 9,5 KG
WEIGHT 9,5 KG

INCLUDE UNA SACCA
DI PROTEZIONE
INCLUDES A PROTEC-
TION BAG



TAPPO DI DRENAGGIO
DRAINING PLUG



TASSELLI, VITI E BOCCOLE IN
NYLON RINFORZATO PER UN
MIGLIORE FISSAGGIO AL SUOLO
DOWELS, SCREWS AND BRUSHES
MADE OF REINFORCED NYLON FOR
BETTER FASTENING TO THE GROUND

COLLEGAMENTO ALL'ACQUA IN UN
SOLO TUBO
CONNECTION TO WATER IN ONLY 1
PIPE

VALVOLA DI INTERCETTA-ZIONE
DELL'ACQUA
VALVE WATER SHUT-OFF

COLLEGAMENTO ACQUA LATERALE 1/2
SIDE WATER CONNECTION

LITRI 40L
LITER 40L

COLORE GRIGIO RAL 7048 + WOOD 001
COLOUR NERA RAL 9004 + NN7851-4

ACCESSORI IN OTTONE BLACK MATT
ACCESSORIES MADE OF BRASS

FILTRO ANTICALCARE ESTERNO INCLUSO
EXTERNAL ANTI-SCALE FILTER INCLUDED



DOCCIA RISCALDAMENTO SOLARE
SOLAR HEATING SHOWER

TUBI INTERNI IN ACCIAIO FINO A 15
KG DI PRESSIONE
BRAIDED STEEL INNER HOSE UP TO
15 KG PRESSURE

CAPACITÀ DEL SERBATORIO 26L
TANK CAPACITY 26L

IL DOPPIO DELLO SPES-SORE. PIÙ
RESISTENTE
TWICE AS THICK. MORE RESISTANT

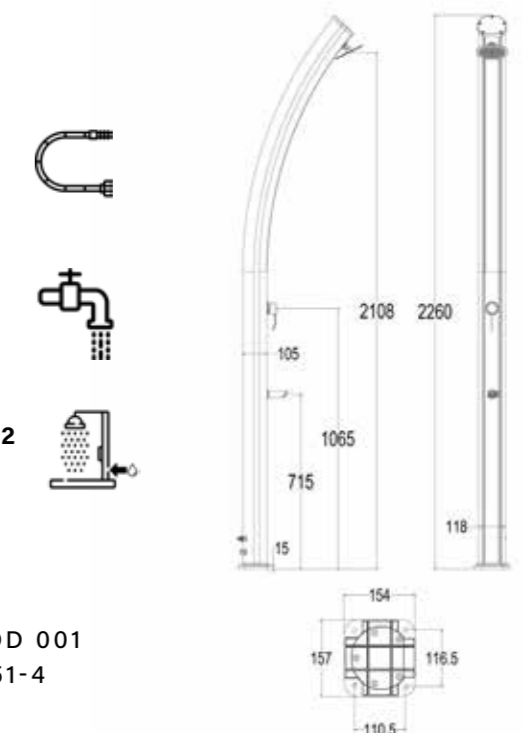
**IT**

Doccia Ecologica Solare
Emi Blu Con Soffione
Rotondo Da 15 Cm
Miscelatore e Rubinetto
Lavapiedi Doccia Con
Struttura Curva In Alluminio
Per Esterno Serbatoio
25 Litri Altezza 226 Cm.
Indicata Per Bordo Piscina,
Giardino, Beb, Hotels,
Campeggi.

EN

Solar Ecological Shower
Emi Blue With 15 Cm Round
Shower Head, Mixer And
Foot Wash Tap Shower
With Curved Aluminium
Structure For Outdoor Use,
25 Litres Tank, Height 226
Cm. Suitable For Poolside,
Garden, b And B, Hotels,
Campsites.

FR

Douche Solaire Écologique
Emi Bleu Avec Pommeau
De Douche Rond De 15 Cm,
Mitigeur Et Rince-pieds.
avec Structure Courbée En
Aluminium Pour L'extérieur,
Réservoir 25 Litres, Hauteur
226 Cm. Convient Pour
La Piscine, le Jardin, Beb,
Hotels, Campings.

DE

Ökologische Solardusche
Emi Blau Mit Rundem
Brausekopf (15 Cm),
Mischbatterie Und
Fußwaschhahn
Bogenförmige Dusche
Aus Aluminium Für Den
Außenbereich, 25-liter-tank,
Höhe 226 Cm. Geeignet
Für Swimmingpools,
Gärten, Beb, Hotels Und

ES

Ducha solar ecológica Emi
Blu con rociador redondo
de 15 cm, mezclador y
grifo de pie Ducha con
estructura de aluminio
curvada para uso exterior,
depósito de 25 litros,
altura 226 cm. Adecuado
para el borde de la piscina,
el jardín, B and B, hoteles,
camping.

DOCCIA-LEA-GRIGIA

DOCCIA-LEA-GRIGIA

8025431016989



ARGENTO
8025431151024

MATERIALE ALLUMINIO
MATERIAL ALUMINIUM

UGELLI ANTICALCARE
ANTISCALE NOZZLES

PESO 13 KG
WEIGHT 13 KG

INCLUDE UNA SACCA
DI PROTEZIONE
INCLUDES A PROTEC-
TION BAG



TAPPO DI DRENAGGIO
DRAINING PLUG



TASSELLI, VITI E BOCCOLE IN
NYLON RINFORZATO PER UN
MIGLIORE FISSAGGIO AL SUOLO
DOWELS, SCREWS AND BRUSHES
MADE OF REINFORCED NYLON FOR
BETTER FASTENING TO THE GROUND

COLLEGAMENTO ALL'ACQUA IN UN
SOLO TUBO
CONNECTION TO WATER IN ONLY 1
PIPE

VALVOLA DI INTERCETTA-ZIONE
DELL'ACQUA
VALVE WATER SHUT-OFF

COLLEGAMENTO ACQUA LATERALE 1/2
SIDE WATER CONNECTION

LITRI 30L
LITER 30L

COLORE GRIGIO RAL 9023
COLOUR NERA RAL 9004

ACCESSORI IN OTTONE BLACK MATT
ACCESSORIES MADE OF BRASS

FILTRO ANTICALCARE ESTERNO INCLUSO
EXTERNAL ANTI-SCALE FILTER INCLUDED



DOCCIA RISCALDAMENTO SOLARE
SOLAR HEATING SHOWER

TUBI INTERNI IN ACCIAIO FINO A 15
KG DI PRESSIONE
BRAIDED STEEL INNER HOSE UP TO
15 KG PRESSURE

CAPACITÀ DEL SERBATORIO 26L
TANK CAPACITY 26L

IL DOPPIO DELLO SPES-SORE. PIÙ
RESISTENTE
TWICE AS THICK. MORE RESISTANT

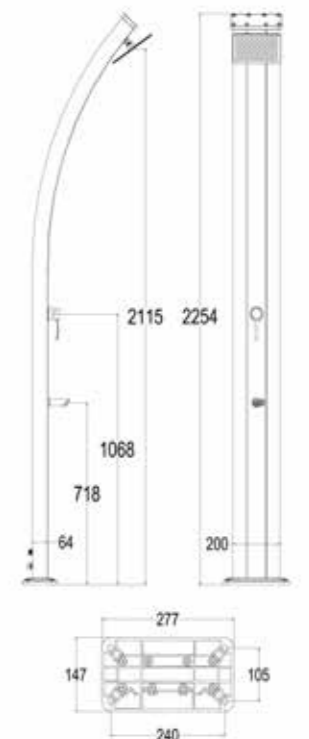

IT

Doccia Per Esterni a Riscaldamento Solare Sined Lea Grigia Doccia Con Struttura Curva In Alluminio e Capiente Serbatoio Da 30 Litri Doccia Alta 225,4 Cm Dotata Di Grande Soffione Quadrato Miscelatore e Rubinetto Lavapiedi Grigio Ral 9023.

EN

Shower For Outdoor Use With Solar Heating Lea Grey Shower With Curved Aluminum Structure And Large Tank Of 30 Liters Shower 225,4 Cm High With Large Square Shower Head Mixer And Foot Washing Tap.

FR

Douche D'extérieur à Chauffage Solaire Lea Couleur Gris Douche Avec Structure En Aluminium Courbée Et Grand Réservoir De 30 Litres Douche De 225,4 Cm De Haut Avec Grand Pommeau De Douche Carrée Mitigeur Et Robinet Rince-pieds.

DE

Solarbeheizte Außendusche Lea Farbe Grau Dusche Mit Gebogener Aluminiumstruktur Und Großem 30-liter-tank Dusche 225,4 Cm Hoch Mit Großer Quadratischer Kopfbrause Mischbatterie Und Fußwaschhahn.

ES

Ducha De Exterior Con Calefacción Solar Lea Grigia Ducha Con Estructura De Aluminio Curvada y Gran Depósito De 30 Litros Ducha De 225,4 Cm De Altura Con Gran Rociador Cuadrado Grifo Mezclador y Grifo De Lavabo De Pie.

FONTANE DA GIARDINO

GARDEN FOUNTAINS

Le fontane da giardino del marchio italiano SINED rappresentano la perfetta combinazione di stile e funzionalità per qualsiasi spazio esterno. Realizzate in polietilene di alta qualità, queste fontane si distinguono per la loro durata e resistenza agli agenti atmosferici, garantendo una lunga vita con una manutenzione minima. Il polietilene utilizzato per la loro costruzione è un materiale robusto che resiste all'esposizione al sole, alla pioggia e alle temperature estreme, mantenendo il suo aspetto

Il design italiano delle fontane da giardino SINED aggiunge un tocco di eleganza e raffinatezza a qualsiasi ambiente. Ogni fontana è progettata con cura per integrarsi armoniosamente in giardini, patii e aree esterne, offrendo un'estetica attraente e contemporanea. Oltre al loro fascino visivo, queste fontane sono progettate per essere pratiche e facili da installare, fornendo un punto focale rilassante e funzionale in qualsiasi spazio esterno.

La scelta del polietilene come materiale principale non solo garantisce la resistenza e la durata delle fontane, ma le rende anche leggere e facili da spostare, consentendo una maggiore flessibilità nella loro collocazione. Le fontane da giardino SINED sono disponibili in vari stili e dimensioni per soddisfare i diversi gusti e le diverse esigenze, dal design minimalista alle opzioni più ornamentali, il tutto mantenendo l'impegno per la qualità e il design per

In breve, le fontane da giardino del marchio italiano SINED sono un'eccellente aggiunta a qualsiasi spazio esterno, combinando la forza e la durata del polietilene di alta qualità con il design elegante e sofisticato per cui l'Italia è nota. Con queste fontane è facile trasformare qualsiasi giardino in un'oasi di tranquillità e bellezza,

The garden fountains from the Italian brand SINED represent the perfect combination of style and functionality for any outdoor space. Made of high quality polyethylene, these fountains stand out for their durability and resistance to weather conditions, guaranteeing a long life with minimal maintenance. The polyethylene used in their construction is a robust material that withstands exposure to sun, rain and extreme temperatures, maintaining its appearance and functionality over time.

The Italian design of SINED garden fountains adds a touch of elegance and sophistication to any environment. Each fountain is carefully designed to blend harmoniously into gardens, patios and outdoor areas, offering an attractive and contemporary aesthetic. In addition to their visual appeal, these fountains are designed to be practical and easy to install, providing a relaxing and functional focal point in any outdoor space.

The choice of polyethylene as the main material not only ensures the fountains' strength and durability, but also makes them lightweight and easy to move, allowing for greater flexibility in their placement. SINED garden fountains are available in various styles and sizes to suit different tastes and needs, all maintaining the commitment to quality and design that the Italian brand is known for.

In short, Italian brand SINED garden fountains are an excellent addition to any outdoor space, combining the strength and durability of high quality polyethylene with the sleek and sophisticated design that Italy is known for. With these fountains, it is easy to transform any garden into an oasis of tranquillity and beauty, enjoying a product that is designed to last and to enhance the aesthetics of its surroundings.



FONTANA-ACQUA

FONTANA-ACQUA-BIANCA

8025431018044



IT

Fontanella Bianca Da Giardino Con Attacco Laterale Acqua Ideale Per Innaffiare Il Giardino o i Spazi Esterni. Realizzata In Polietilene Ad Alta Resistenza. Predisposizione Per Attacchi Rapidi Tubo Da Giardino Tutto Il Necessario Per Il Facile Montaggio.

EN

White Garden Fountain With Side Water Connection Ideal For Watering The Garden Or Outdoor Spaces. Made Of High Resistance Polyethylene. Prearranged For Garden Hose Quick Couplings Everything You Need For An Easy Assembly.

FR

Fontaine de jardin blanche avec raccord d'eau latéral, idéale pour arroser le jardin ou les espaces extérieurs. Fabriquée en polyéthylène haute résistance. Predisposition pour un raccordement rapide des tuyaux d'arrosage. Assemblage rapide et facile.

DE

Weißer Gartenbrunnen Mit Seitlichem Wasseranschluss, Ideal Für Die Bewässerung Des Gartens Oder Von Außenbereichen. Hergestellt Aus Hochfestem Polyethylen. Ausgelegt Für Gartenschlauch-schnellkupplungen Alles, Was Für Eine Einfache

ES

Fuente De Jardín Blanca Con Conexión De Agua Lateral Ideal Para Regar El Jardín o Los Espacios Exteriores. Fabricado En Polietileno De Alta Resistencia. Predisposición Para Acoplamiento Rápidos De Mangueras De Jardín. Fácil y Rápido Montaje.



NERO
8025431017825



ROSSO
8025431018051



TORTORA
8025431018068



VERDE
8025431017832

DIMENSIONI H100CM - Ø 15CM
DIMENSIONS H100CM - Ø 15CM

COLORE BIANCO - RAL 9003
NERO - RAL 9017
ROSSO - RAL 3028
TORTORA - RAL 7030
VERDE - RAL 6016

PESO 3,3 KG
WEIGHT 3,3 KG

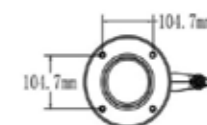

**IT**

Fontanella Da Giardino Rossa Acqua Pro Della Sined. Attacco Laterale Acqua Per Innaffiare Qualsiasi Spazio Esterno. Realizzata In Polietilene Ad Alta Resistenza. Tubo Flessibile 7,5 Mt Esterno e Pistola a Spruzzo Con 8 Getti Diversi. Facile Montaggio.

EN

Red Garden Fountain Acqua Pro By Sined. Side Water Connection For Watering Any Outdoor Space. Made Of High Resistance Polyethylene. Flexible Hose 7,5 Mt External And Spray Gun With 8 Different Jets. Easy Assembly.

FR

Fontaine De Jardin Rouge Acqua Pro De Sined. Raccordement Latéral Pour L'arrosage De Tout Espace Extérieur. Fabriqué En Polyéthylène Haute Résistance. Flexible Externe De 7,5 m Et Pistolet De Pulvérisation Avec 8 Jets Différents. Montage Facile.

DE

ACQUA PRO roter Gartenbrunnen von Sined. Seitlicher Wasseranschluss für die Bewässerung aller Außenbereiche. Hergestellt aus hochbeständigem Polyethylen. Externer 7,5 m langer flexibler Schlauch und Spritzpistole mit 8 verschiedenen Düsen. Einfache Montag.

ES

Fuente De Jardín Roja Acqua Pro De Sined. Conexión De Agua Lateral Para Regar Cualquier Espacio Exterior. Fabricado En Polietileno De Alta Resistencia. Manguera Externa De 7,5 m y Pistola Con 8 Chorros Diferentes. Fácil Montaje.

FONTANA-ACQUA-PRO

FONTANA-ACQUA-PRO-ROSSA
8025431017955



DIMENSIONI H100CM - Ø 8 CM
DIMENSIONS H100CM - Ø 8 CM

COLORE BIANCO - RAL 9003
NERO - RAL 9017
ROSSO - RAL 3028
TORTORA - RAL 7030
VERDE - RAL 6016

PESO 5,8KG
WEIGHT 5,8 KG

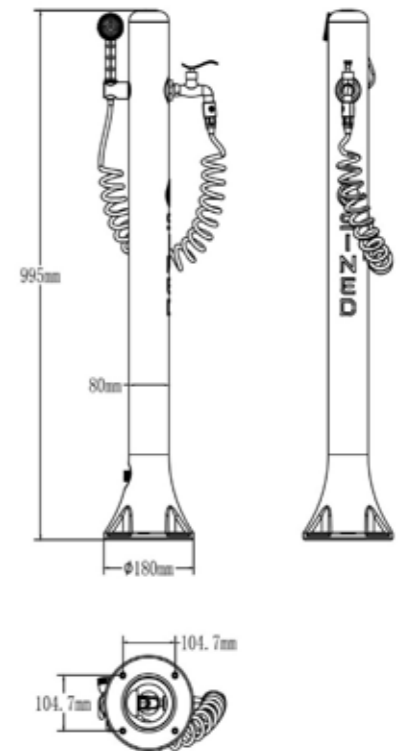

FONTANA-TRITONE

FONTANA-TRITONE-NERA

8025431017849



IT

Fontanella Da Giardino Nera Modello Tritone Con Con Predisposizione Per Attacchi Rapidi Tubo Da Giardino. Diametro 15 Cm Altezza 100 Cm. Fontanella Realizzata In Hdpe (polietilene Ad Alta Resistenza) Resistente Ai Raggi Uv, Al Calcare Ed Alla Salsedine.

EN

Garden Fountain Black Model Tritone With Predisposition For Quick Connection Garden Hose. Diameter 15 Cm Height 100 Cm. Fountain Made Of Hdpe (high Resistance Polyethylene) Resistant To Uv Rays, Limestone And Saltiness.

FR

Fontaine De Jardin Noire Modèle Tritone Avec Disposition Pour Les Raccords Rapides Des Tuyaux D'arrosage. Diamètre 15 Cm, Hauteur 100 Cm. Fontaine En Hdpe (polyéthylène Haute Résistance) Résistant Aux Rayons Uv, Au Calcaire Et à La Salinité.

DE

Gartenbrunnen Schwarz, Modell Tritone, Mit Vorrichtung Für Gartenschlauch-schnellkupplungen. Durchmesser 15 Cm Höhe 100 Cm. Brunnen Aus Hdpe (hochresistentes Polyethylen), Beständig Gegen Uv-strahlen, Kalk Und Salzwasser.

ES

Fuente De Jardín Negra Modelo Tritone Con Disposición Para Acoples Rápidos De Manguera De Jardín. Diámetro 15 Cm Altura 100 Cm. Fuente Fabricada En Hdpe (polietileno De Alta Resistencia) Resistente a Los Rayos Uv, a La Cal y a La Salinidad.



ROSSA
8025431017917



BIANCA
8025431017900



TORTORA
8025431017924



VERDE
8025431017856

DIMENSIONI H100CM - Ø 15CM
DIMENSIONS H100CM - Ø 15CM

COLORE BIANCO - RAL 9003
NERO - RAL 9017
ROSSO - RAL 3028
TORTORA - RAL 7030
VERDE - RAL 6016

PESO 7,7 KG
WEIGHT 7,7 KG

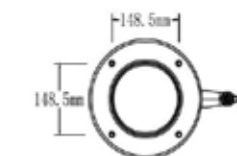
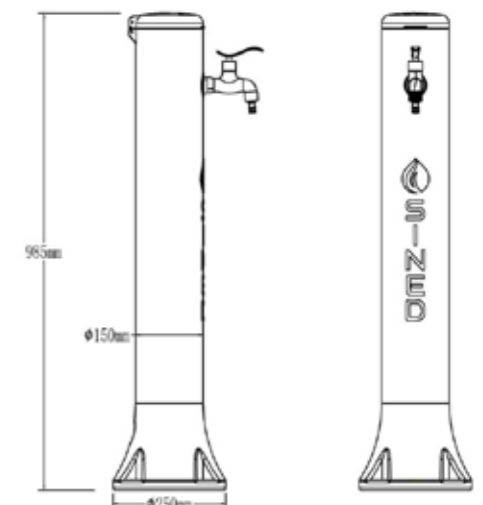

FONTANA-TRITONE-PRO

FONTANA-TRITONE-PRO-BIANCA

8025431018075



NERA
8025431018082

ROSSA
8025431018099

TORTORA
8025431018105

VERDE
8025431018112

DIMENSIONI H100CM - Ø 15CM
DIMENSIONS H100CM - Ø 15CM

COLORE BIANCO - RAL 9003
NERO - RAL 9017
ROSSO - RAL 3028
TORTORA - RAL 7030
VERDE - RAL 6016

PESO 9,5 KG
WEIGHT 9,5 KG

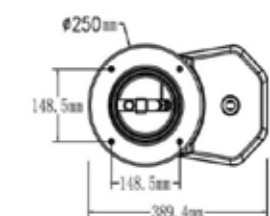
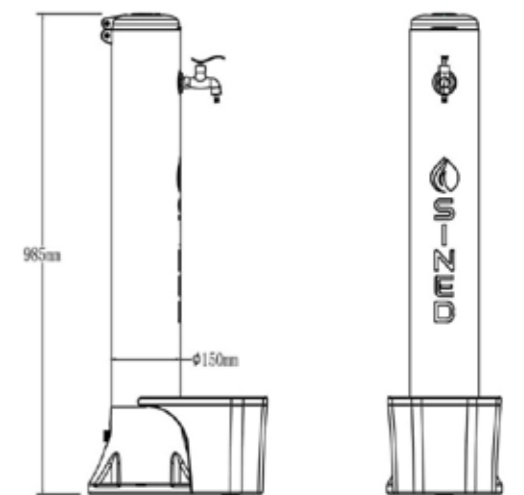

IT

Fontana Bianca Da Giardino Ad Acqua Fredda Fornita Di Rubinetto, Vaschetta Recupero Acqua Con Griglia In Alluminio Raccogli Foglie e Tubo Flessibile Interno. Doppio Attacco Acqua. Per Tutte Le Attività All'aperto, Anche Ambienti Marini.

EN

White Garden Fountain With Cold Water Supplied With Tap, Water Tank With Aluminium Grid For Leaves Collection And Internal Flexible Hose. Double Water Connection. For All Outdoor Activities, Even Marine Environments.

FR

Fontaine de jardin blanche à eau froide, équipée d'un robinet, d'un bac de récupération de l'eau avec grille en aluminium pour recueillir les feuilles et d'un tuyau flexible interne. Double connexion d'eau. Pour toutes les activités de plein air, y compris.

DE

Weißer Gartenbrunnen Mit Kaltem Wasser, Ausgestattet Mit Wasserhahn, Wasserauffangschale Mit Aluminiumgitter Zum Auffangen Von Laub Und Internem Flexiblen Schlauch. Doppelter Wasseranschluss. Für Alle Aktivitäten Im Freien, Auch

ES

Fuente de jardín blanca con agua fría, equipada con manguera. Bandeja de recogida de agua con rejilla de aluminio para recoger las hojas. Manguera flexible interna. Doble conexión de agua. Para actividades al aire libre, incluso en entornos cerca del mar.



IT

Fontana verde per esterno e secchiello con capacità 5 litri, griglia in alluminio raccogli foglie Doppio attacco acqua laterale e inferiore. Realizzato in polietilene ad alta resistenza. Rubinetto in lega metallica nera con attacco rapido tubo da giardino.

EN

Outdoor Green Fountain And Bucket With 5 Liters Capacity, Aluminum Grid Leaf Catcher Double Side And Bottom Water Connection. Made Of High Resistance Polyethylene. Black Metal Alloy Tap With Garden Hose Quick Coupling.

FR

Fontaine verte d'extérieur et seau d'une capacité de 5 litres, grille ramasse-feuilles en aluminium. Double raccordement à l'eau sur le côté et le fond. Fabriqué en polyéthylène haute résistance. Robinet en alliage métallique noir avec raccord rapide pour tuyau d'arrosage.

DE

Grüner Springbrunnen und Eimer für den Außenbereich mit 5 Liter Fassungsvermögen, Laubfanggitter aus Aluminium Doppelter Wasseranschluss an der Seite und am Boden. Hergestellt aus hochfestem Polyethylen. Wasserhahn aus schwarzer Metalllegierung mit Schnellkupplung für

ES

Fuente verde de exterior y cubo con 5 litros de capacidad, rejilla de aluminio para recoger las hojas Doble conexión de agua en el lateral y en el fondo. Fabricado en polietileno de alta resistencia. Grifo de aleación metálica negra con acoplamiento rápido.

KIT FONTANA-TRITONE

KIT FONTANA-TRITONE-VERDE

8025431018334



ROSSA
8025431018310



BIANCA
8025431018297



TORTORA
8025431018327



NERA
8025431018303

DIMENSIONI H100CM - Ø 15CM
DIMENSIONS H100CM - Ø 15CM

COLORE BIANCO - RAL 9003
NERO - RAL 9017
ROSSO - RAL 3028
TORTORA - RAL 7030
VERDE - RAL 6016

PESO 9 KG
WEIGHT 9 KG

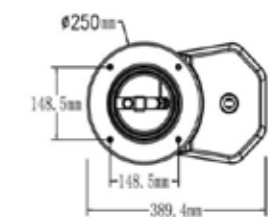
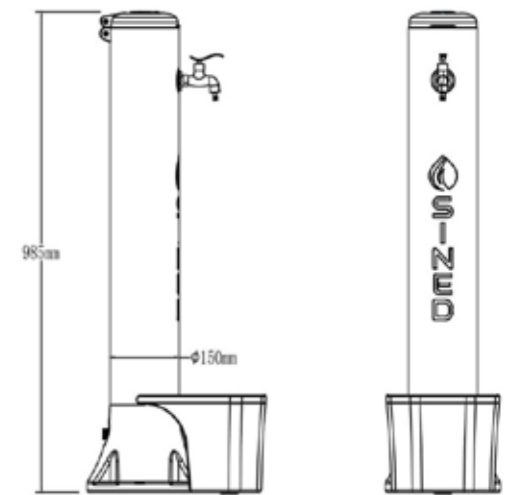

CHAISE LONGUE SUN LINGUERS

I lettini da esterno del marchio italiano SINED rappresentano una perfetta combinazione di design elegante e materiali di alta qualità, ideali per case con giardini o piscine. Realizzati in polietilene o in fibra di vetro, offrono un'eccezionale durata e resistenza agli agenti atmosferici, garantendo una lunga durata anche in caso di uso costante all'aperto.

Il design italiano di SINED aggiunge un tocco di raffinatezza e stile contemporaneo a qualsiasi spazio esterno. Ogni lettino è progettato per il massimo comfort, con forme ergonomiche che si adattano al corpo, permettendo di godere di momenti di relax all'aperto. La fibra di vetro offre una struttura robusta e leggera, mentre il polietilene garantisce resistenza agli agenti

I lettini SINED sono progettati per integrarsi armoniosamente in giardini e piscine. Il loro design moderno e funzionale li rende una scelta eccellente per chi desidera combinare lusso e praticità nei propri spazi esterni.

Il marchio italiano SINED garantisce la qualità di ogni pezzo, assicurando che ogni lettino non solo soddisfi i più alti standard di design e comfort, ma sia anche un investimento duraturo per qualsiasi casa con giardino o piscina.

The outdoor sun loungers from the Italian brand SINED represent a perfect combination of elegant design and high quality materials, ideal for homes with gardens or swimming pools. Made of polyethylene or fibreglass, they offer exceptional durability and resistance to weather conditions, ensuring a long service life even with constant outdoor use.

SINED's Italian design adds a touch of sophistication and contemporary style to any outdoor space. Each lounge is designed for maximum comfort, with ergonomic shapes that conform to the body, allowing you to enjoy relaxing moments outdoors. The fibreglass provides a robust and lightweight structure, while the polyethylene guarantees weather resistance and easy maintenance.

SINED sun loungers are designed to blend harmoniously into gardens and pool areas. Their modern and functional design makes them an excellent choice for those looking to combine luxury and practicality in their outdoor spaces.

The Italian brand SINED guarantees the quality of each piece, ensuring that each sun lounge not only meets the highest standards of design and comfort, but is also a long-lasting investment for any home with a garden or pool.



CHAISE-LONGUE-CASSIOPEA

8025431017412

**REALIZZATE IN POLIETILENE PER
USO ALIMENTARE.
MADE OF POLYETHYLENE FOR FOOD
USE.**



**GALLEGGIANO SULL'ACQUA.
POSSIBILITÀ DI RIEMPIRLI D'ACQUA.
FLOAT ON WATER. POSSIBILITY TO
FILL THEM WITH WATER.**

**LED OPZIONALE PER ILLUMINARE LE
SDRAIO DI NOTTE.
OPTIONAL LED SPOTLIGHT TO
ILLUMINATE THE SUN LOUNGER AT
NIGHT.**

**DIMENSIONI 212X89X74 (CM)
DIMENSION 212X89X74 (CM)**

**PESO 22 KG
WEIGHT 22 KG**

**COLORE BIANCO
COLOUR WHITE**

**MATERIALE PE HD
MATERIAL PE HD**

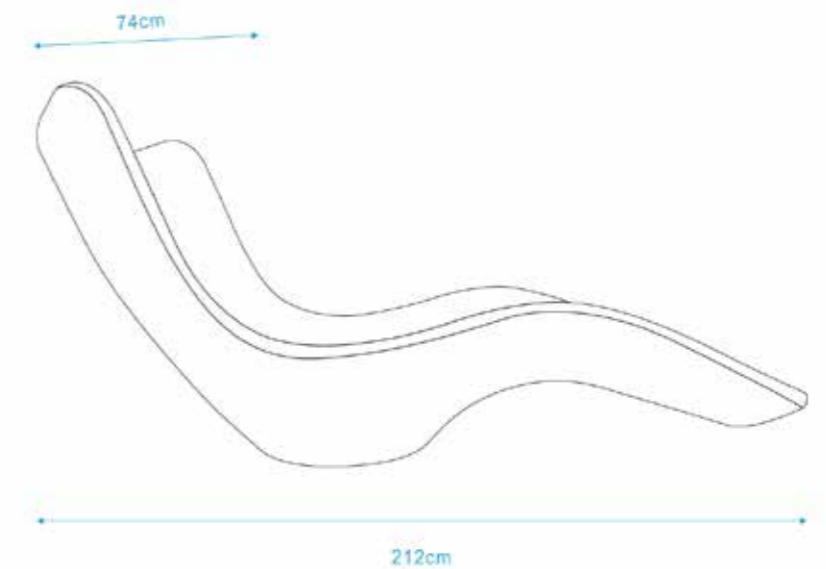

IT

Chaise Longue Cassiopea
Letino Da Piscina Bianco,
Giardino, Mare Realizzato In
Polietilene Di Alta Qualità,
Resiste Agli Uv, Ergonomica
Leggera e Facilmente
Igenizzabile. Design
Moderno Per Tutti Gli
Ambienti Esterni e Interni.
Dimensioni 212x89x103cm.

EN

Chaise Longue Cassiopea
Swimming Pool Lounger
White, Garden, Sea Made Of
High Quality Polyethylene,
Uv Resistant, Ergonomic,
Lightweight And Easily
Sanitized. Modern Design
For All Outdoor And Indoor
Environments. Dimensions
212x89x103cm.

FR

CHAISE LONGUE
CASSIOPEA chaise longue
de piscine en blanc, jardin,
plage en polyéthylène de
haute qualité, résistant aux
UV, ergonomique, légère et
facile à nettoyer. Un design
moderne pour tous les
environnements extérieurs
et intérieurs. Dimensions
212x89x103cm.

DE

Chaise Longue Cassiopea
Schwimmbadliege In
Weiß, Garten, Strand
Aus Hochwertigem
Polyethylen, Uv-beständig,
Ergonomisch, Leicht Und
Einfach Zu Reinigen.
Modernes Design Für Alle
Außen- Und Innenbereiche.
Abmessungen
212x89x103cm.

ES

Chaise Longue Cassiopea.
Tumbona De Piscina,
Jardín o Playa En
Blanco. De Alta Calidad,
Resistente a Los Rayos
Uv, Ergonómica, Ligera y
Fácil De Limpiar. Diseño
Moderno Para Todos Los
Ambientes Exteriores e
Interiores. Dimensiones
212x89x103cm.

CHAISE-LONGUE-SIRIO

8025431017436

**REALIZZATE IN POLIETILENE PER
USO ALIMENTARE.
MADE OF POLYETHYLENE FOR FOOD
USE.**



**GALLEGGIANO SULL'ACQUA.
POSSIBILITÀ DI RIEMPIRLI D'ACQUA.
FLOAT ON WATER. POSSIBILITY TO
FILL THEM WITH WATER.**

**LED OPZIONALE PER ILLUMINARE LE
SDRAIO DI NOTTE.
OPTIONAL LED SPOTLIGHT TO
ILLUMINATE THE SUN LOUNGER AT
NIGHT.**

**DIMENSIONI 178X62X91 (CM)
DIMENSION 178X62X91 (CM)**

**PESO 18 KG
WEIGHT 18 KG**

**COLORE BIANCO
COLOUR WHITE**

**MATERIALE PE HD
MATERIAL PE HD**

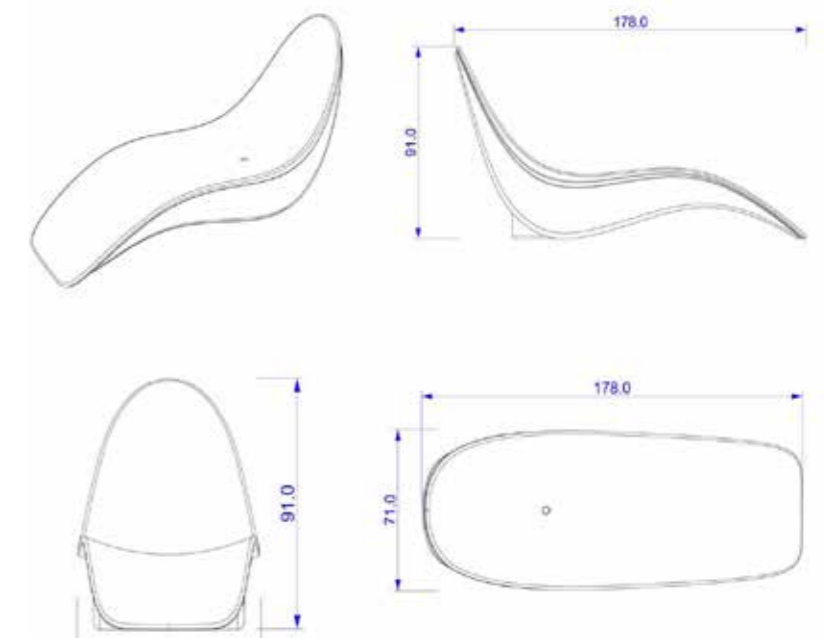

IT

Chaise Longue Sirio Lounge
Chair Colore Bianco.
Interamente Realizzato
In Pe Di Alta Qualità,
Moderno, Articolo Di Lusso,
Resistente All'acqua. Ottimo
Per Uso Interno e Esterno.
Molto Resistente Ai Raggi
Uv Riciclabile. Dimensioni
178x62x91 Cm.

EN

Chaise Longue Sirio Lounge
Chair White Color. Entirely
Made Of High Quality Pe,
Modern, Luxury Item, Water
Resistant. Great For Indoor
And Outdoor Use. Very
Uv Resistant Recyclable.
Dimensions 178x62x91 Cm.

FR

Chaise Longue Chaise
Longue Sirio En Blanc.
Entièrement Fabriqué En Pe
De Haute Qualité, Article
Moderne Et Luxueux,
Résistant à L'eau. Excellent
Pour Une Utilisation
Intérieure Et Extérieure.
Très Résistant Aux Uv,
Recyclable. Dimensions
178x62x91 Cm.

DE

Chaise Longue Sirio
Loungesessel In
Weiß. Vollständig Aus
Hochwertigem Pe, Modern,
Luxuriös Und Wasserfest.
Hervorragend Für Den
Innen- Und Außenbereich
Geeignet. Sehr Uv-
beständig, Recyclbar.
Abmessungen 178x62x91
Cm.

ES

Chaise Longue Sined
Sirio. Tumbona En Blanco.
Totalmente Fabricado
En Pe De Alta Calidad,
Moderno, Artículo De
Lujo, Resistente Al Agua.
Excelente Para Uso En
Interiores y Exteriores.
Muy Resistente a Los
Rayos Uv, Reciclable.
Dimensiones 178x62x91cm.

IT

Chaise Longue Bianca In Vetroresina Adatta Per Un Uso Intensivo Sia Per Esterno Che Interno. Forma Anatomica Perfetta Pe Ril Massimo Comfort Con Dimensioni 178x71x91 Cm. Molto Resistente Ai Raggi Uv e Di Facile Pulizia e Manutenzione.

**EN**

White Fibreglass Chaise Longue Suitable For Intensive Use Both Outdoors And Indoors. Anatomical Shape Perfect For Maximum Comfort With Dimensions 178x71x91 Cm. Very Uv Resistant And Easy To Clean And Maintain.

FR

Chaise Longue En Fibre De Verre Blanche Convenant à Un Usage Intensif En Extérieur Et En Intérieur. Forme Anatomique Parfaite Pour Un Confort Maximal Avec Des Dimensions De 178x71x91 Cm. Très Résistant Aux Uv Et Facile à Nettoyer Et à Entretienir.

DE

Weißer Chaiselongue Aus Fiberglas Für Den Intensiven Gebrauch Im Freien Und Im Haus. Anatomische Form Für Maximalen Komfort Mit Den Maßen 178x71x91 Cm. Sehr Uv-beständig Und Leicht Zu Reinigen Und Zu Pflegen.

ES

Chaise Longue De Fibra De Vidrio Blanca Apta Para Uso Intensivo En Exteriores e Interiores. Forma Anatómica Perfecta Para Un Máximo Confort Con Dimensiones 178x71x91 Cm. Muy Resistente a Los Rayos Uv y Fácil De Limpiar y Mantener.

CHAISE-LONGUE-VENERE

8025431017450



REALIZZATE IN FIBRA DI VETRO.
MASSIMA STABILITÀ, CONFORT
E RESISTENZA ALLE PERATURE
ESTREME.

MADE OF FIBREGLASS. MAXIMUM
STABILITY, COMFORT AND RESISTANCE



DIMENSIONI 178X62X91 (CM)

DIMENSION 178X62X91 (CM)

PESO 18 KG

WEIGHT 18KG

COLORE BIANCO

COLOUR WHITE

MATERIALE VETRORESINA

MATERIAL VETRORESINA

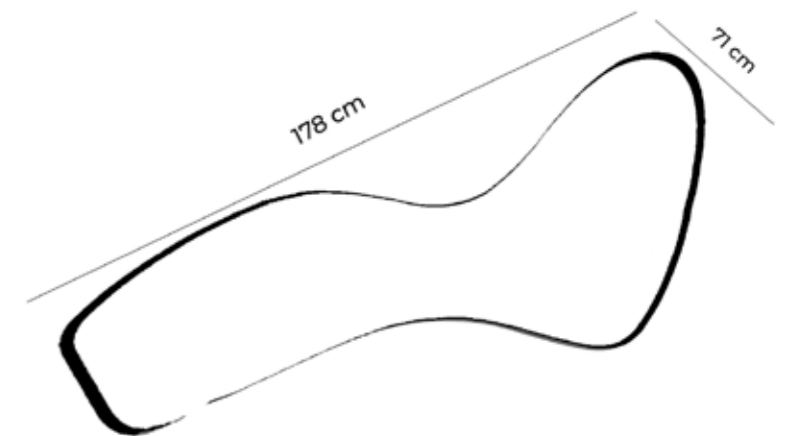

OGGETTI LUMINOSI SOLARI SOLAR LUMINOUS OBJECTS

Gli oggetti solari luminosi per esterni del marchio italiano SINED si distinguono per il design elegante e l'innovativa tecnologia sostenibile. Realizzati in polietilene di alta qualità, questi oggetti offrono una durata eccezionale e una resistenza superiore agli agenti atmosferici, garantendo il mantenimento della loro funzionalità e del loro fascino estetico nel tempo. Sfruttando l'energia solare, questi oggetti forniscono un'illuminazione efficiente ed ecologica, eliminando la necessità di complicati cablaggi o collegamenti elettrici. La luce morbida e calda che emettono crea un'atmosfera rilassante e incantevole, ideale per godersi le serate all'aperto.

La tecnologia solare integrata garantisce un'illuminazione costante ed efficiente, alimentata dall'energia solare durante il giorno e attivata automaticamente al crepuscolo. Questo non solo riduce il consumo energetico e i costi, ma contribuisce anche alla tutela dell'ambiente. Gli oggetti solari luminosi di SINED sono facili da installare e da mantenere, offrendo una soluzione pratica e sostenibile per l'illuminazione esterna.

Realizzati in polietilene di alta qualità, gli oggetti luminosi solari per esterni di SINED combinano design elegante, tecnologia avanzata e sostenibilità. Forniscono un'illuminazione d'ambiente che valorizza qualsiasi spazio esterno, offrendo durata, efficienza e stile, e sono un'ottima aggiunta per chi desidera migliorare l'estetica e la funzionalità dei propri giardini o terrazze in modo ecologico e sofisticato.

The outdoor solar light objects from the Italian brand SINED are distinguished by their elegant design and innovative sustainable technology. Made of high-quality polyethylene, these objects offer exceptional durability and superior weather resistance, ensuring that they retain their functionality and aesthetic appeal over time. Harnessing solar energy, these objects provide efficient and environmentally friendly lighting, eliminating the need for complicated wiring or electrical connections. The soft, warm light they emit creates a relaxing and enchanting atmosphere, ideal for enjoying outdoor evenings.

Integrated solar technology ensures constant and efficient lighting, powered by solar energy during the day and automatically activated at dusk. This not only reduces energy consumption and costs, but also helps to protect the environment. SINED's solar light objects are easy to install and maintain, offering a practical and sustainable solution for outdoor lighting.

Made of high-quality polyethylene, SINED's solar outdoor light objects combine elegant design, advanced technology and sustainability. They provide ambient lighting that enhances any outdoor space, offering durability, efficiency and style, and are an excellent addition for those wishing to enhance the aesthetics and functionality of their gardens or terraces in an environmentally



VASO-ROTONDO-SOLAR

VASO-ROTONDO-SOLAR-86
8025431151147



VASO-ROTONDO-SOLAR-102
8025431151130



IT

Vaso Luminoso
Autoricaricabile Solare In
Polietilene Modello Rotondo
Solar Con Altezza 86 Cm.
Vaso Luminoso Solare Fatto
In Italia, Resistente Agli Urti,
Agli Agenti Atmosferici e
Ai Raggi Uv. Possibilità Di
Essere Usato Tutto L'anno.

EN

Solar Self-recharging
Luminous Vase Made
Of Polyethylene Model
Rotondo Solar With Height
86 Cm. Solar Luminous
Vase Made In Italy, Impact,
Weather And Uv Resistant.
Possibility To Be Used All
Year Round.

FR

Vase Solaire à Chargement
Automatique Rotondo Solar
En Polyéthylène, Hauteur
86 Cm. Vase Solaire
Fabriqué En Italie, Résistant
Aux Chocs, Aux Intempéries
Et Aux Uv. Peut Être Utilisé
Toute L'année.

DE

Rotondo Solar
Selbstladende
Solarlichtvase Aus
Polyethylen, Höhe 86
Cm. Solar-lichtvase,
Hergestellt In Italien,
Stoßfest, Wetterfest Und
Uv-beständig. Kann Das
Ganze Jahr Über Verwendet
Werden.

ES

Jarrón Con Luz Solar
Autocargable Rotondo
Solar De Polietileno, Altura
86 Cm. Jarrón Con Luz
Solar Fabricado En Italia,
Resistente a Los Golpes,
a La Intemperie y a Los
Rayos Uv. Puede Utilizarse
Durante Todo El Año.

**SI RICARICANO AUTONOMAMENTE CON LA LUCE SOLARE.
RECHARGE THEMSELVES WITH SUNLIGHT.**

**SENZA DOVER COLLEGARE IL CAVO DI ALIMENTAZIONE.
WITHOUT HAVING TO CONNECT THE POWER CABLE.**

**ACCENSIONE E SPEGNIMENTO AUTOMATICI.
AUTOMATIC SWITCHING ON AND OFF.**

**BATTERIA AL LITIO E TELECOMANDO INCLUSI.
LITHIUM BATTERY AND REMOTE CONTROL INCLUDED.**

**COLORE BIANCO
COLOUR WHITE**

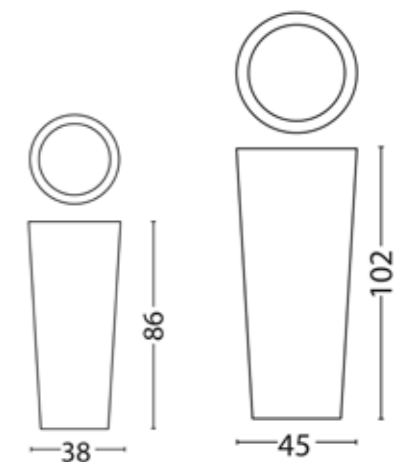

VASO-QUADRATO-SOLAR

VASO-QUADRATO-SOLAR-86
8025431151123

VASO-QUADRATO-SOLAR-102
8025431151116



IT

Vaso Luminoso
Autoricaricabile Solare
In Polietilene Modello
Quadrato Solar Con Altezza
86 Cm. Vaso Luminoso
Solare Con Telecomando
Fatto In Italia, Resistente
Agli Urti, Agli Agenti
Atmosferici e Ai Raggi Uv.
Possibilità Di Essere Usato
Tutto L'anno.

**SI RICARICANO AUTONOMAMENTE CON LA LUCE SOLARE.
RECHARGE THEMSELVES WITH SUNLIGHT.**

**SENZA DOVER COLLEGARE IL CAVO DI ALIMENTAZIONE.
WITHOUT HAVING TO CONNECT THE POWER CABLE.**

**ACCENSIONE E SPEGNIMENTO AUTOMATICI.
AUTOMATIC SWITCHING ON AND OFF.**

**BATTERIA AL LITIO E TELECOMANDO INCLUSI.
LITHIUM BATTERY AND REMOTE CONTROL INCLUDED.**

**COLORE BIANCO
COLOUR WHITE**

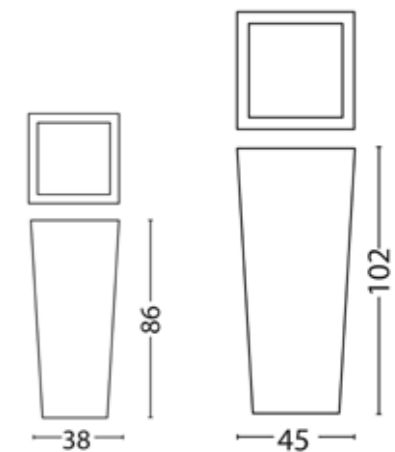

EN

Solar Self-recharging
Luminous Vase Made
Of Polyethylene Model
Quadrato Solar With Height
86 Cm. Solar Luminous
Vase Made In Italy, Impact,
Weather And Uv Resistant.
Possibility To Be Used All
Year Round.

FR

Vase Solaire Quadrato
Solar En Polyéthylène
Autorechargeable D'une
Hauteur De 86 Cm. Vase
Solaire Fabriqué En Italie,
Résistant Aux Chocs, Aux
Intempéries Et Aux Uv. Peut
Être Utilisé Toute L'année.

DE

Quadrato Solar
Selbstauflüllende Solar-
lichtvase Aus Polyethylen,
Höhe 86 Cm. Solar-
lichtvase, Hergestellt In
Italien, Stoßfest, Wetterfest
Und Uv-beständig. Kann
Das Ganze Jahr Über
Verwendet Werden.

ES

Jarrón De Luz Solar
De Polietileno
Autorrecargable Quadrato
Solar Con Una Altura
De 86 Cm. Jarrón Con
Luz Solar Fabricado En
Italia, Resistente a Los
Golpes, a La Intemperie y
a Los Rayos Uv. Se Puede
Utilizar Durante Todo El
Año.

SGABELLO-LUMINOSO

SGABELLO-LUMINOSO-KAMIS
8025431151086



SGABELLO-LUMINOSO-PAR
8025431151093



IT

Sgabello Luminoso Par
Autoricaricabile Solare
Realizzato In Polietilene
Di Alta Qualità. Si Ricarica
Con L'energia Solare.
Stabile e Sicuro In Tutte Le
Situazioni. Ideale Anche
Come Complemento Di
Arredo Interno o Esterno.

EN

Solar Self-recharging Par
Light Stool Made Of High
Quality Polyethylene. It
Recharges With Solar
Energy. Stable And Safe In
All Situations. Also Ideal
As An Indoor Or Outdoor
Furnishing Accessory.

FR

Tabouret Lumineux Par
Solaire Auto-rechargeable
En Polyéthylène De Haute
Qualité. Se Recharge à
L'énergie Solaire. Stable
Et Sûr Dans Toutes Les
Situations. Idéal Également
Comme Accessoire
D'ameublement Pour
L'intérieur Ou L'extérieur.

DE

Selbstauf ladender
Solar-par-lichthocker
Aus Hochwertigem
Polyethylen. Lädt Sich
Mit Sonnenenergie Auf.
Stabil Und Sicher In Allen
Situationen. Ideal Auch Als
Einrichtungsaccessoire Für
Dinnen Und Draußen.

ES

Taburete Luminoso Par
Solar Autorrecargable
Fabricado En Polietileno
De Alta Calidad. Se
Recarga Con Energía
Solar. Estable y Seguro
En Todas Las Situaciones.
También Es Ideal Como
Accesorio De Decoración
Interior o Exterior.

SI RICARICANO AUTONOMAMENTE CON LA LUCE SOLARE.
RECHARGE THEMSELVES WITH SUNLIGHT.

SENZA DOVER COLLEGARE IL CAVO DI ALIMENTAZIONE.
WITHOUT HAVING TO CONNECT THE POWER CABLE.

ACCENSIONE E SPEGNIMENTO AUTOMATICI.
AUTOMATIC SWITCHING ON AND OFF.

BATTERIA AL LITIO E TELECOMANDO INCLUSI.
LITHIUM BATTERY AND REMOTE CONTROL INCLUDED.

COLORE BIANCO
COLOUR WHITE

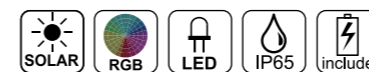

A++ A+ A

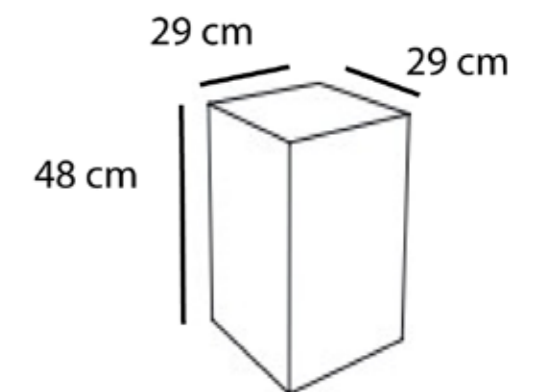

SFERA-LUCE

SFERA-LUCE-30
8025431151048



SFERA-LUCE-40
8025431151055



SFERA-LUCE-50
8025431151185



IT

Sfera Luminosa Sined Professionale Stagna Per Hotel Ristoranti Diametro 50 Cm Lampada Da Terra Munita Di Pannello Fotovoltaico e Luce Led Colori Intercambiabili Dal Telecomando Sfera Solare Realizzata In Polietilene Lldpe Made In Italy Luce Fredda 6000k.

EN

Sined Luminous Sphere Professional Waterproof For Hotel Restaurants Diameter 50 Cm Floor Lamp Equipped With Photovoltaic Panel And Led Light Interchangeable Colors Solar Sphere Made Of Polyethylene Lldpe Made In Italy Cold Light 6000k.

FR

Sined sphère lumineuse professionnelle étanche pour hôtels restaurants Diamètre 50 cm Lampadaire équipé d'un panneau photovoltaïque et d'une lumière LED couleurs interchangeables Sphère solaire en LLDPE Polyéthylène Fabriqué en Italie lumière froide 6000k.

DE

Sined Professionelle Wasserdichte Kugel Licht Für Hotels Restaurants Durchmesser 50 Cm Stehleuchte Ausgestattet Mit Photovoltaik-panel Und Led-licht Austauschbare Farben Solarkugel Aus Lldpe Polyethylen Made In Italy Kaltes Licht 6000k.

ES

Sined Esfera Impermeable Profesional Para Hoteles Restaurantes Diámetro 50 Cm Lámpara De Pie Equipada Con Panel Fotovoltaico y Luz Led Colores Intercambiables Esfera Solar De Polietileno Lldpe Fabricada En Italia Luz Fría 6000k.

**SI RICARICANO AUTONOMAMENTE CON LA LUCE SOLARE.
RECHARGE THEMSELVES WITH SUNLIGHT.**

**SENZA DOVER COLLEGARE IL CAVO DI ALIMENTAZIONE.
WITHOUT HAVING TO CONNECT THE POWER CABLE.**

**ACCENSIONE E SPEGNIMENTO AUTOMATICI.
AUTOMATIC SWITCHING ON AND OFF.**

**BATTERIA AL LITIO E TELECOMANDO INCLUSI.
LITHIUM BATTERY AND REMOTE CONTROL INCLUDED.**

**COLORE BIANCO
COLOUR WHITE**

**PESO 2 KG
WEIGHT 2KG**

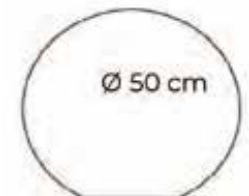
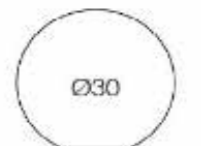

TAVOLINO-LUMINOSO-CUBY

8025431151109



**SI RICARICANO AUTONOMAMENTE CON LA LUCE SOLARE.
RECHARGE THEMSELVES WITH SUNLIGHT.**

**SENZA DOVER COLLEGARE IL CAVO DI ALIMENTAZIONE.
WITHOUT HAVING TO CONNECT THE POWER CABLE.**

**ACCENSIONE E SPEGNIMENTO AUTOMATICI.
AUTOMATIC SWITCHING ON AND OFF.**

**BATTERIA AL LITIO E TELECOMANDO INCLUSI.
LITHIUM BATTERY AND REMOTE CONTROL INCLUDED.**

**COLORE BIANCO
COLOUR WHITE**



50 cm

50 cm

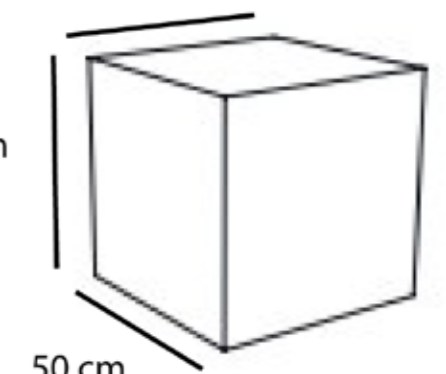

50 cm

IT

Tavolino Luminoso Con Pannello Solare e Batteria Cuby Autoricaricabile Solare Realizzato In Polietilene Di Alta Qualità. Si Ricarica Con L'energia Solare. Stabile e Sicuro In Tutte Le Situazioni. Ideale Anche Come Arredo Interno o Esterno.

EN

Luminous Coffee Table With Solar Panel And Solar Self-recharging Cuby Battery Made Of High Quality Polyethylene. It Recharges With Solar Energy. Stable And Safe In All Situations. Also Ideal As Indoor Or Outdoor Furniture.

FR

Table D'appoint Lumineuse Avec Panneau Solaire Et Batterie Solaire Rechargeable Cuby En Polyéthylène De Haute Qualité. Elle Se Recharge à L'énergie Solaire. Stable Et Sûre Dans Toutes Les Situations. Idéale Comme Mobilier D'intérieur Ou D'extérieur.

DE

Leuchtendes Beistelltischchen Mit Solarpanel Und Wiederaufladbarem Cuby-akku Aus Hochwertigem Polyethylen. Er Wird Mit Solarenergie Aufgeladen. Stabil Und Sicher In Allen Situationen. Ideal Auch Als Innen- Oder Außenmöbel.

ES

Mesa Auxiliar Luminosa Con Panel Solar y Batería Solar Recargable Cuby De Polietileno De Alta Calidad. Se Recarga Con Energía Solar. Estable y Segura En Todas Las Situaciones. Ideal También Como Mueble De Interior o Exterior.

BOA-LUMINOSA-SOLARE

8025431151154



IT

Boa Luminosa Galleggiante
Con Pannello Solare
Interno Che Si Autoricarica.
Boa Solare Galleggiante
Luminosa In Pe Bianco
Opaco Si Ricarica
Autonomamente Con La
Luce Solare. Ovunque Ci
Sia Bisogno Di Segnalare o
Delimitare In Acqua. Made
In Italy.

EN

Floating Light Buoy With
Internal Solar Panel That
Self-recharges. Bright
Floating Solar Buoy
Made Of Opaque White
Pe Recharges Itself With
Sunlight. Wherever There
Is a Need To Signal Or
Delineate In The Water.
Made In Italy.

FR

Bouée flottante lumineuse
avec panneau solaire
interne auto-rechargeable.
La bouée flottante en
plastique blanc opaque
se recharge de façon
autonome grâce à la
lumière solaire. Partout où
il est nécessaire de signaler
ou de délimiter dans l'eau.
Fabriquée en Italie.

DE

Schwimmende
Leuchtboje mit internem
selbstauffladendem
Solarpanel. Solar-
Leuchtboje aus opakem
weißem Pe lädt sich
selbständig mit Solarlicht
auf. Überall dort, wo
eine Signalisierung oder
Abgrenzung im Wasser
erforderlich ist. Hergestellt
in Italien.

ES

Boya Flotante Luminosa
Con Panel Solar Interno
Auto-Recargable. Boya
Flotante Solar Luminosa
Fabricada en Pe Blanco
Opaco Se Carga
Autónomamente con
Luz Solar. Dondequiera
que haya necesidad
de señalización o
delimitación en el agua.
Fabricada en Italia.

**SI RICARICANO AUTONOMAMENTE CON LA LUCE SOLARE.
RECHARGE THEMSELVES WITH SUNLIGHT.**

**SENZA DOVER COLLEGARE IL CAVO DI ALIMENTAZIONE.
WITHOUT HAVING TO CONNECT THE POWER CABLE.**

**ACCENSIONE E SPEGNIMENTO AUTOMATICI.
AUTOMATIC SWITCHING ON AND OFF.**

**BATTERIA AL LITIO E TELECOMANDO INCLUSI.
LITHIUM BATTERY AND REMOTE CONTROL INCLUDED.**

**COLORE BIANCO
COLOUR WHITE**

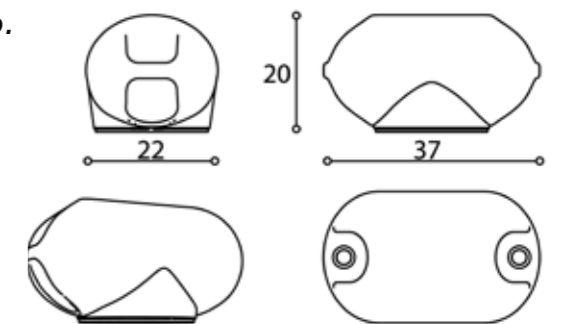

cm

CAMINETTI DA INCASSO

RECESSED ELECTRIC FIREPLACE

INSTALLAZIONE ANCHE A FILO MURO. UNICI IN EUROPA

I caminetti da Incasso Sined sono gli modelli in Europa con certificazioni di risparmio energetico ERP2009/125/CE. Funzionamento in base alla temperatura reale, grazie al sensore di temperatura, al termostato e al timer settimanale. Conformità alle direttive UE Verificata da una società di certificazione esterna Europea.

IN-WALL INSTALLATION. UNIQUE MODEL IN EUROPE

Sined recessed fireplaces are the models in Europe with energy-saving certification ERP2009/125/EC. Operation based on actual temperature, thanks to temperature sensor, thermostat and weekly timer. Compliance with EU directives Verified by an external European certification company.



CAMINETTO-VULCANO

8025431019263

60 CM



DIMENSIONI 49,5X60X15 CM
DIMENSIONS 49,5X60X15 CM

TIPO DI CALORE TERMOCONVETTORE 750-1500W
HEAT TYPE CONVECTOR 750-1500W

COLORE NERO
COLOUR BLACK

PESO 10 KG
WEIGHT 10 KG

**UNICI MODELLI IN EUROPA
 CERTIFICATI E TESTATI PER INCASSO
 COMPLETO.
 THE ONLY MODELS IN EUROPE THAT ARE
 CERTIFIED AND TESTED FOR COMPLETE
 EMBEDDING.**



EU directives compliance
 LVD 2014/35/UE EMC 2014/30/UE
 DERP 2009/125/CE
 RoHS 2011/65/EU ((UE) 2015/863)

**DOPPIA MODALITA' DI
 FUNZIONAMENTO:
 DUAL MODE OF OPERATION:**

Solo effetto fiamma ultra realistico o riscaldante con motore PCT da 1500w sigillato ermeticamente. Vetro cristallo temperato. Pannello di controllo LCD frontale. Comandi manuali laterali, uscita e ingresso dell'aria sono posizionati nella parte superiore. Il caminetto è imballato in una scatola di cartone rinforzato.

ATTENZIONE! I caminetti da parete sono progettati per essere appesi alla parete. Non devono essere installati/incassati all'interno.

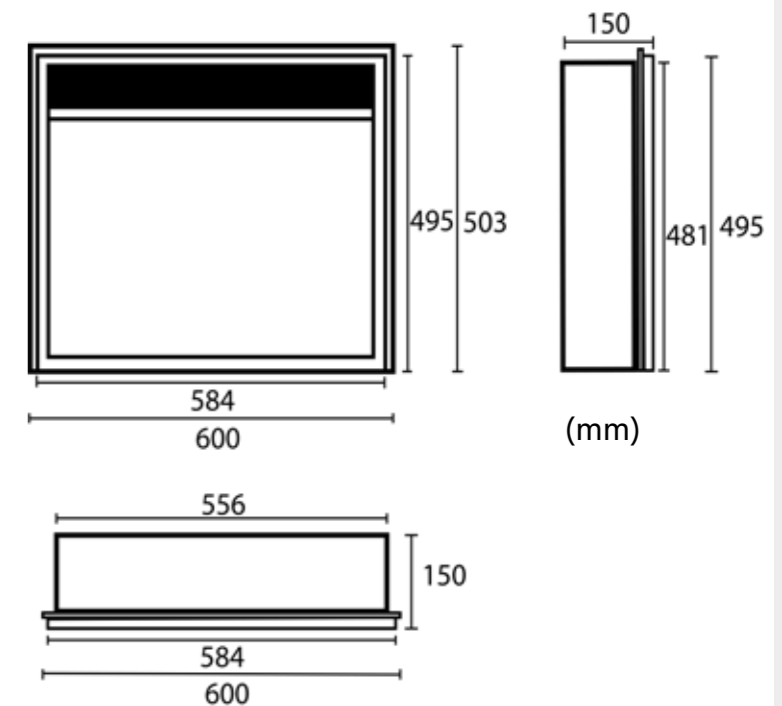

IT

Nuovo caminetto elettrico LED con reale effetto fiamma LED. Potenza di riscaldamento 0-750-1.500W. Braciere elettrico per tutte le stagioni, potrai usare il solo effetto fiamma senza accendere il riscaldamento. Potrai comandarlo con il telecomando a corredo o manualmente dal pannello di controllo frontale.



EN

New LED electric fireplace with real LED flame effect. Heating power 0-750-1,500W. All-season electric brazier, you can use only the flame effect without switching on the heater. You can control it with the supplied remote control or manually from the front control panel.

FR

Nouvelle cheminée électrique LED avec effet de flamme LED réel. Puissance de chauffage 0-750-1,500W. Brasero électrique toutes saisons, vous pouvez utiliser uniquement l'effet de flamme sans allumer le chauffage. Vous pouvez le contrôler avec la télécommande fournie ou manuellement depuis le panneau de commande avant.

DE

Neuer LED-Elektrokamin mit echtem LED-Flammeneffekt. Heizleistung 0-750-1.500W. Allwetter-Elektrokochfeld, Sie können nur den Flammeneffekt nutzen, ohne die Heizung einzuschalten. Sie können ihn mit der mitgelieferten Fernbedienung oder manuell über das vordere Bedienfeld steuern.

ES

Nueva chimenea eléctrica de LED con efecto de llama de LED real. Potencia de calentamiento 0-750-1.500W. Brasero eléctrico para todo tipo de clima, puede utilizar sólo el efecto de la llama sin encender el calentador. Puedes controlarlo con el mando a distancia suministrado o manualmente desde el panel de control frontal.

CAMINETTO-PANAREA

8025431019270

75 CM



DIMENSIONI 75X62,5X18 CM
DIMENSIONS 75X62,5X18 CM

TIPO DI CALORE TERMOCONVETTORE 750-1500W
HEAT TYPE CONVECTOR 750-1500W

COLORE NERO
COLOUR BLACK

PESO 19,7 KG
WEIGHT 19,7 KG

**UNICI MODELLI IN EUROPA CERTIFICATI
 E TESTATI PER INCASSO COMPLETO.
 THE ONLY MODELS IN EUROPE THAT ARE
 CERTIFIED AND TESTED FOR COMPLETE
 EMBEDDING.**



EU directives compliance
 LVD 2014/35/UE EMC 2014/30/UE
 DERP 2009/125/CE
 RoHS 2011/65/EU ((UE) 2015/863)

**DOPPIA MODALITA' DI
 FUNZIONAMENTO:
 DUAL MODE OF OPERATION:**

Solo effetto fiamma ultra realistico o riscaldante con motore PCT da 1500w sigillato ermeticamente. Vetro cristallo temperato. Pannello di controllo LCD frontale. Comandi manuali laterali, uscita e ingresso dell'aria sono posizionati nella parte superiore. Il caminetto è imballato in una scatola di cartone rinforzato.

ATTENZIONE! I caminetto da parete sono progettati per essere appesi alla parete. Non devono essere installati/incassati all'interno.

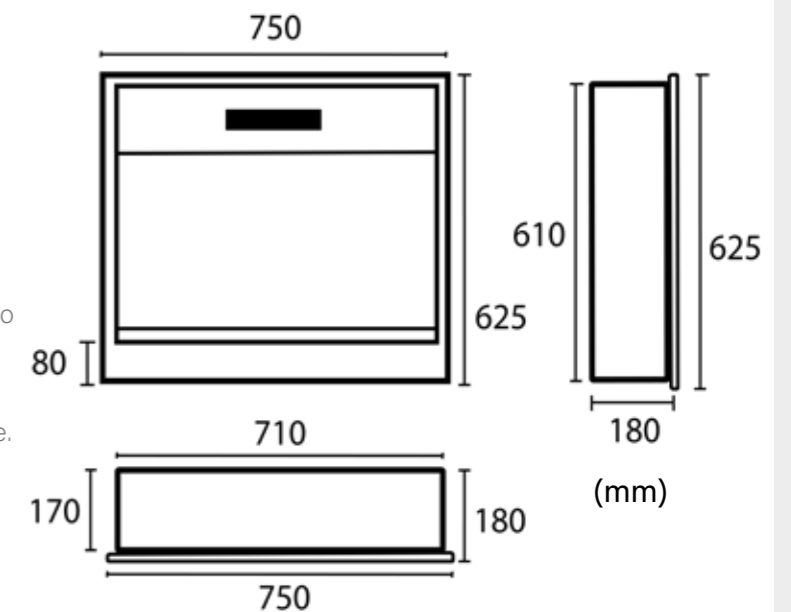

IT

Inserto per caminetti elettrici modello Panarea. Bruciatore elettrico da incasso anche per caminetti esistenti. Potenza riscaldante 1500W con telecomando incluso. Può essere usato anche con il solo effetto fiamma anche in estate. Comandabile dal telecomando o dal display sul pannello frontale.



EN

Insert for electric fireplaces model Panarea. Built-in electric burner also for existing fireplaces. Heating power 1500W with remote control included. Can also be used with the flame effect alone in summer. Can be controlled from the remote control or the display on the front panel. Heat output from the top front.

FR

Insert pour cheminées électriques modèle Panarea. Brûleur électrique intégré, également pour les cheminées existantes. Puissance de chauffe 1500W avec télécommande incluse. Peut également être utilisé avec l'effet flamme seul en été. Peut être contrôlé à partir de la télécommande ou de l'écran du panneau avant. Sortie de chaleur par le haut de la façade.

DE

Einsatz für elektrische Kamine Modell Panarea. Eingebauter Elektrobrenner auch für bestehende Kamine. Heizleistung 1500W, inklusive Fernbedienung. Kann im Sommer auch allein mit dem Flammeneffekt verwendet werden. Kann über die Fernbedienung oder das Display an der Frontplatte gesteuert werden.

ES

Inserto para chimeneas eléctricas modelo Panarea. Quemador eléctrico incorporado también para chimeneas existentes. Potencia de 1500W con mando a distancia. También se puede utilizar solo efecto llama. Se puede controlar desde el mando a distancia o panel frontal. Salida de calor por la parte superior delantera.

CAMINETTO-ISPICA-108

8025431151079

108 CM



DIMENSIONI 108X50X20 CM
DIMENSIONS 108X50X20 CM

TIPO DI CALORE TERMOCONVETTORE 750-1500W
HEAT TYPE CONVECTOR 750-1500W

COLORE NERO
COLOUR BLACK

PESO 30 KG
WEIGHT 30 KG

**UNICI MODELLI IN EUROPA CERTIFICATI
 E TESTATI PER INCASSO COMPLETO.
 THE ONLY MODELS IN EUROPE THAT ARE
 CERTIFIED AND TESTED FOR COMPLETE
 EMBEDDING.**



EU directives compliance
 LVD 2014/35/UE EMC 2014/30/UE
 DERP 2009/125/CE
 RoHS 2011/65/EU ((UE) 2015/863)

**DOPPIA MODALITA' DI
 FUNZIONAMENTO:
 DUAL MODE OF OPERATION:**

Solo effetto fiamma ultra realistico o riscaldante con motore PCT da 1500w sigillato ermeticamente. Vetro cristallo temperato. Pannello di controllo LCD frontale. Comandi manuali laterali, uscita e ingresso dell'aria sono posizionati nella parte superiore. Il caminetto è imballato in una scatola di cartone rinforzato.

ATTENZIONE! I caminetti da parete sono progettati per essere appesi alla parete. Non devono essere installati/incassati all'interno.

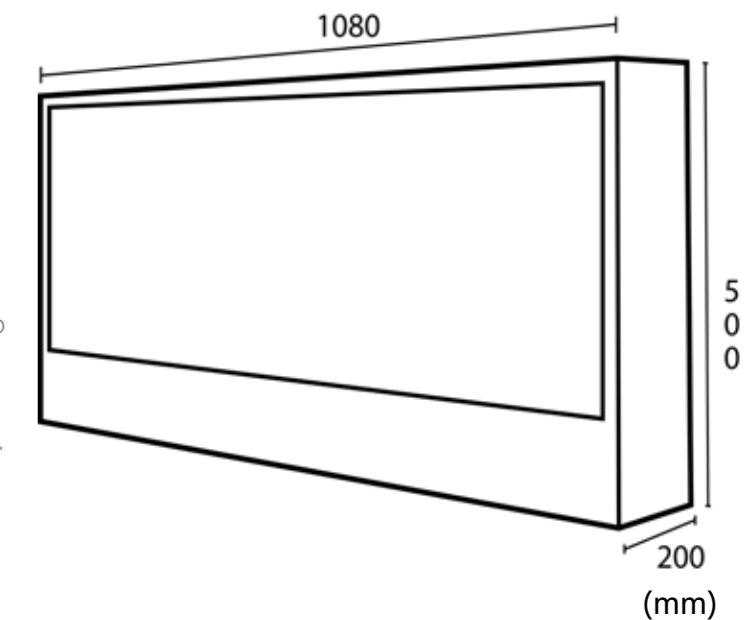

IT

Vero complemento di arredo è il caminetto elettrico nero da incasso o appoggio modello ISPICA, 108 cm di lunghezza, effetto fiamma realizzato mediante LED e regolabile come intensità, 6 livelli. Due step di potenza 750-1500W. Possibilità di comandarlo manualmente o con il telecomando incluso. Possibilità di usare il solo effetto fiamma.



EN

A true furnishing accessory is the black electric fireplace for flush-mounting or standing, model ISPICA, 108 cm long, flame effect created by LEDs and adjustable in intensity, 6 levels. Two power steps 750-1500W. Can be controlled manually or with the included remote control. Possibility of using only the flame effect.

FR

Véritable accessoire d'ameublement, la cheminée électrique noire à encastrer ou à poser, modèle ISPICA, 108 cm de long, effet flamme créé par des LED et réglable en intensité, 6 niveaux. Deux niveaux de puissance 750-1500W. Contrôlable manuellement ou à l'aide de la télécommande fournie. Possibilité d'utiliser uniquement l'effet de flamme.

DE

Ein echtes Einrichtungsaccessoire ist der schwarze Elektrokamin zum Einbau oder zum Aufstellen, Modell ISPICA, 108 cm lang, Flammeneffekt durch LEDs erzeugt und in der Intensität einstellbar, 6 Stufen. Zwei Leistungsstufen 750-1500W. Kann manuell oder mit der mitgelieferten Fernbedienung gesteuert werden.

ES

Un verdadero accesorio de decoración es la chimenea eléctrica negra para empotrar o de pie, modelo ISPICA, 108 cm de largo, efecto de llama creado por LED y regulable en intensidad, 6 niveles. Dos niveles de potencia 750-1500W. Se puede controlar manualmente o con el mando a distancia incluido. Posibilidad de utilizar sólo el efecto de llama.

CAMINETTO-VULTURE-150

8025431016897

150 CM



DIMENSIONI 50,7X20X150 CM
DIMENSIONS 50,7X20X150 CM

TIPO DI CALORE TERMOCONVETTORE 750-1500W
HEAT TYPE CONVECTOR 750-1500W

COLORE NERO
COLOUR BLACK

PESO 30 KG
WEIGHT 30 KG

**UNICI MODELLI IN EUROPA CERTIFICATI
 E TESTATI PER INCASSO COMPLETO.
 THE ONLY MODELS IN EUROPE THAT ARE
 CERTIFIED AND TESTED FOR COMPLETE
 EMBEDDING.**



EU directives compliance
 LVD 2014/35/UE EMC 2014/30/UE
 DERP 2009/125/CE
 RoHS 2011/65/EU ((UE) 2015/863)

**DOPPIA MODALITA' DI
 FUNZIONAMENTO:
 DUAL MODE OF OPERATION:**

Solo effetto fiamma ultra realistico o riscaldante con motore PCT da 1500w sigillato ermeticamente. Vetro cristallo temperato. Pannello di controllo LCD frontale. Comandi manuali laterali, uscita e ingresso dell'aria sono posizionati nella parte superiore. Il caminetto è imballato in una scatola di cartone rinforzato.

ATTENZIONE! I caminetti da parete sono progettati per essere appesi alla parete. Non devono essere installati/incassati all'interno.

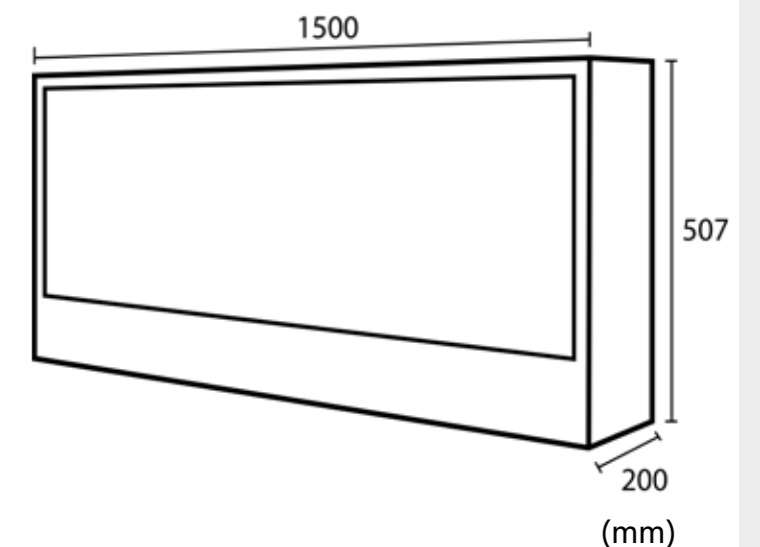

IT

Vero complemento di arredo è il caminetto elettrico nero da incasso o appoggio modello Vulture, 150 cm di lunghezza, effetto fiamma realizzato mediante LED e regolabile come intensità, 6 livelli. Due step di potenza 750-1500W. Possibilità di comandarlo manualmente o con il telecomando incluso.



EN

A true furnishing accessory is the black electric fireplace for flush-mounting or standing, model Vulture, 150 cm long, flame effect created by LEDs and adjustable in intensity, 6 levels. Two power steps 750-1500W. Can be controlled manually or with the included remote control.

FR

Un véritable accessoire d'ameublement est la cheminée électrique noire à encastrer ou à poser, modèle Vulture, 150 cm de long, effet de flamme créé par des LED et réglable en intensité, 6 niveaux. Deux paliers de puissance 750-1500W. Peut être contrôlé manuellement ou avec la télécommande incluse.

DE

Ein echtes Einrichtungsaccessoire ist der schwarze Elektrokamin zum Einbau oder zum Aufstellen, Modell Vulture, 150 cm lang, Flammeneffekt durch LEDs erzeugt und in der Intensität einstellbar, 6 Stufen. Zwei Leistungsstufen 750-1500W. Kann manuell oder mit der mitgelieferten Fernbedienung gesteuert werden.

ES

Un verdadero accesorio de decoración es la chimenea eléctrica negra para empotrar o de pie, modelo Vulture, de 150 cm de longitud, efecto de llama creado por LEDs y regulable en intensidad, 6 niveles. Dos niveles de potencia 750-1500W. Se puede controlar manualmente o con el mando a distancia incluido.

CAMINETTO-AMIATA-180

8025431016859

180 CM



DIMENSIONI 50,7X20X180 CM
DIMENSIONS 50,7X20X180 CM

TIPO DI CALORE TERMOCONVETTORE 750-1500W
HEAT TYPE CONVECTOR 750-1500W

COLORE NERO
COLOUR BLACK

PESO 36 KG
WEIGHT 36 KG

**UNICI MODELLI IN EUROPA CERTIFICATI
E TESTATI PER INCASSO COMPLETO.
THE ONLY MODELS IN EUROPE THAT ARE
CERTIFIED AND TESTED FOR COMPLETE
EMBEDDING.**



EU directives compliance
LVD 2014/35/UE EMC 2014/30/UE
DERP 2009/125/CE
RoHS 2011/65/EU ((UE) 2015/863)

DOPPIA MODALITA' DI FUNZIONAMENTO: DUAL MODE OF OPERATION:

Solo effetto fiamma ultra realistico o riscaldante con motore PCT da 1500w sigillato ermeticamente. Vetro cristallo temperato. Pannello di controllo LCD frontale. Comandi manuali laterali, uscita e ingresso dell'aria sono posizionati nella parte superiore. Il caminetto è imballato in una scatola di cartone rinforzato.

ATTENZIONE! I caminetti da parete sono progettati per essere appesi alla parete. Non devono essere installati/incassati all'interno.

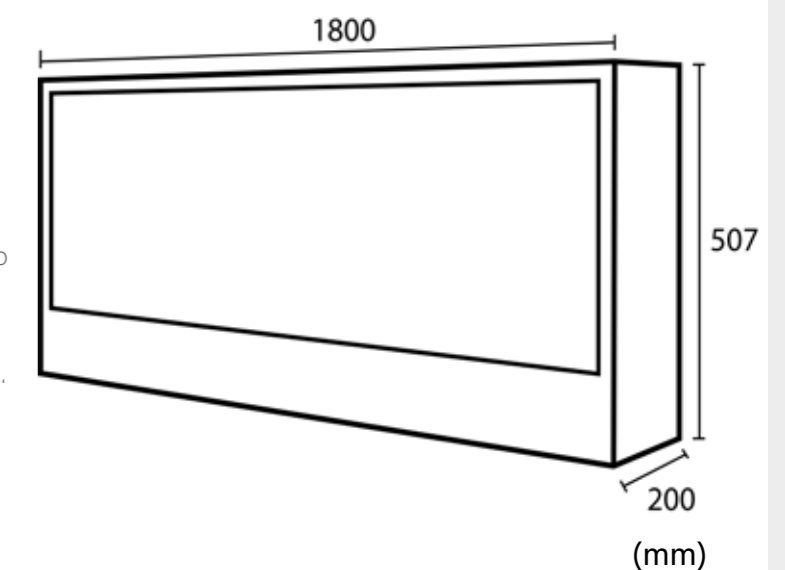

IT

Grande caminetto elettrico da incasso e appoggio modello Amiata, 180 cm di lunghezza, effetto fiamma realizzato mediante LED e regolabile come intensità. Due step di potenza 750-1500W. Possibilità di comandarlo manualmente o con il telecomando incluso. Possibilità di usare il solo effetto fiamma senza la funzione riscaldamento.



EN

Large built-in and freestanding electric fireplace model Amiata, 180 cm long, flame effect realised by LEDs and adjustable intensity. Two power steps 750-1500W. Can be controlled manually or with the included remote control. Possibility of using only the flame effect without the heating function.

FR

Grande cheminée électrique encastrable et autoportante modèle Amiata, 180 cm de long, effet de flamme réalisé par des LEDs et intensité réglable. Deux paliers de puissance 750-1500W. Peut être contrôlé manuellement ou avec la télécommande incluse. Possibilité d'utiliser uniquement l'effet de flamme sans la fonction de chauffage.

DE

Großer Einbau- und freistehender Elektrokamin Modell Amiata, 180 cm lang, Flammeneffekt durch LED und einstellbare Intensität. Zwei Leistungsstufen 750-1500W. Kann manuell oder mit der mitgelieferten Fernbedienung gesteuert werden. Es besteht die Möglichkeit, nur den Flammeneffekt ohne Heizfunktion zu nutzen.

ES

Gran chimenea eléctrica empotrada e independiente modelo Amiata, de 180 cm de longitud, efecto llama LED y de intensidad regulable. Dos niveles de potencia 750-1500W. Se puede controlar manualmente o con el mando a distancia incluido. Posibilidad de utilizar sólo el efecto de la llama sin la función de calentamiento.

CAMINETTO-ETNA-300

8025431016866

3 METRI



DIMENSIONI 50,7X20X300 CM
DIMENSIONS 50,7X20X300 CM

TIPO DI CALORE TERMOCONVETTORE 750-1500W
HEAT TYPE CONVECTOR 750-1500W

COLORE NERO
COLOUR BLACK

PESO 63 KG
WEIGHT 63 KG

**UNICI MODELLI IN EUROPA CERTIFICATI
 E TESTATI PER INCASSO COMPLETO.
 THE ONLY MODELS IN EUROPE THAT ARE
 CERTIFIED AND TESTED FOR COMPLETE
 EMBEDDING.**



EU directives compliance
 LVD 2014/35/UE EMC 2014/30/UE
 DERP 2009/125/CE
 RoHS 2011/65/EU ((UE) 2015/863)

**DOPPIA MODALITA' DI
 FUNZIONAMENTO:
 DUAL MODE OF OPERATION:**

Solo effetto fiamma ultra realistico o riscaldante con motore PCT da 1500w sigillato ermeticamente. Vetro cristallo temperato. Pannello di controllo LCD frontale. Comandi manuali laterali, uscita e ingresso dell'aria sono posizionati nella parte superiore. Il caminetto è imballato in una scatola di cartone rinforzato.

ATTENZIONE! I caminetti da parete sono progettati per essere appesi alla parete. Non devono essere installati/incassati all'interno.

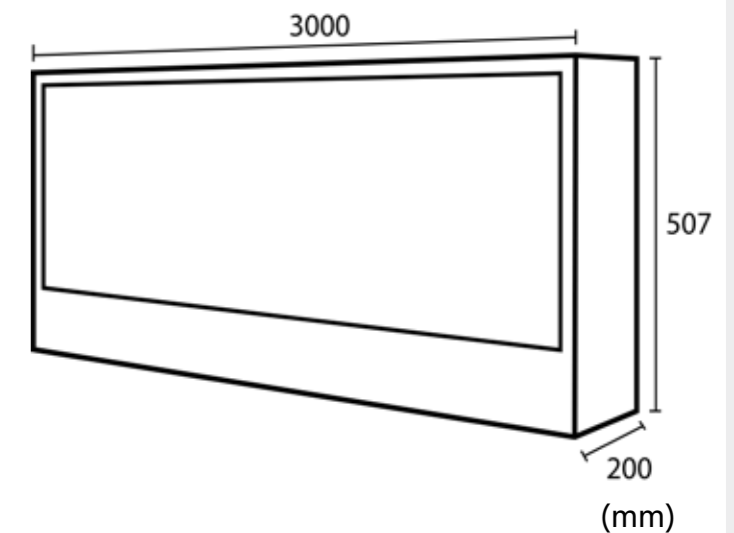

IT

Imponente caminetto elettrico da incasso o appoggio modello Etna, 300 cm di lunghezza, effetto fiamma realizzato mediante LED e regolabile come intensità. Due step di potenza 750-1500W. Possibilità di comandarlo manualmente o con il telecomando incluso. Possibilità di usare il solo effetto fiamma senza la funzione riscaldamento.



EN

Impressive built-in or free-standing electric fireplace model Etna, 300 cm long, flame effect realised by LED and adjustable in intensity. Two power steps 750-1500W. Can be controlled manually or with the included remote control. Possibility of using only the flame effect without the heating function.

FR

Impressionnante cheminée électrique à encastrer ou à poser modèle Etna, 300 cm de long, effet de flamme réalisé par LED et réglable en intensité. Deux paliers de puissance 750-1500W. Peut être contrôlé manuellement ou avec la télécommande incluse. Possibilité d'utiliser uniquement l'effet de flamme sans la fonction de chauffage.

DE

Beeindruckender Einbau- oder freistehender Elektrokamin Modell Etna, 300 cm lang, Flammeneffekt durch LED realisiert und in der Intensität einstellbar. Zwei Leistungsstufen 750-1500W. Kann manuell oder mit der mitgelieferten Fernbedienung gesteuert werden. Es besteht die Möglichkeit, nur den Flammeneffekt ohne Heizfunktion zu nutzen.

ES

Impresionante chimenea eléctrica empotrada o independiente modelo Etna, de 300 cm de longitud, efecto de llama LED regulable en intensidad. Dos niveles de potencia 750-1500W. Se puede controlar manualmente o con el mando a distancia incluido. Posibilidad de utilizar sólo el efecto de la llama sin la función de calentamiento.

CAMINETTI DA PARETE

WALL FIREPLACES

SI APPENDONO ALLA PARETE COME UN QUADRO!

Unici modelli in Europa con certificazioni di risparmio energetico ERP2009/125/CE. Funzionano in base alla temperatura reale, grazie al sensore di temperatura e al termostato e al programmatore settimanale. Conformità alle direttive UE aggiornate verificata da una società di certificazione esterna Europea.

HANGS ON THE WALL LIKE A PAINTING

The only models in Europe with ERP2009/125/EC energy-saving certifications. They operate according to actual temperature, thanks to the temperature sensor and thermostat and weekly programmer. Compliance with updated EU directives verified by an external European certification company.



CAMINETTO-PARETE-MONTE-BIANCO

8025431019225

98 CM



DIMENSIONI 98X55X14 CM
DIMENSIONS 98X55X14 CM

TIPO DI CALORE TERMOCONVETTORE 750-1500W
HEAT TYPE CONVECTOR 750-1500W

COLORE BIANCO
COLOUR WHITE

PESO 15,6 KG
WEIGHT 15,6 KG

**UNICI MODELLI IN EUROPA CERTIFICATI
 E TESTATI PER IL MONTAGGIO A
 PARETE.**

**THE ONLY MODELS IN EUROPE CERTIFIED
 AND TESTED FOR WALL MOUNTING.**

EU directives compliance
 LVD 2014/35/UE EMC 2014/30/UE
 DERP 2009/125/CE
 RoHS 2011/65/EU ((UE) 2015/863)

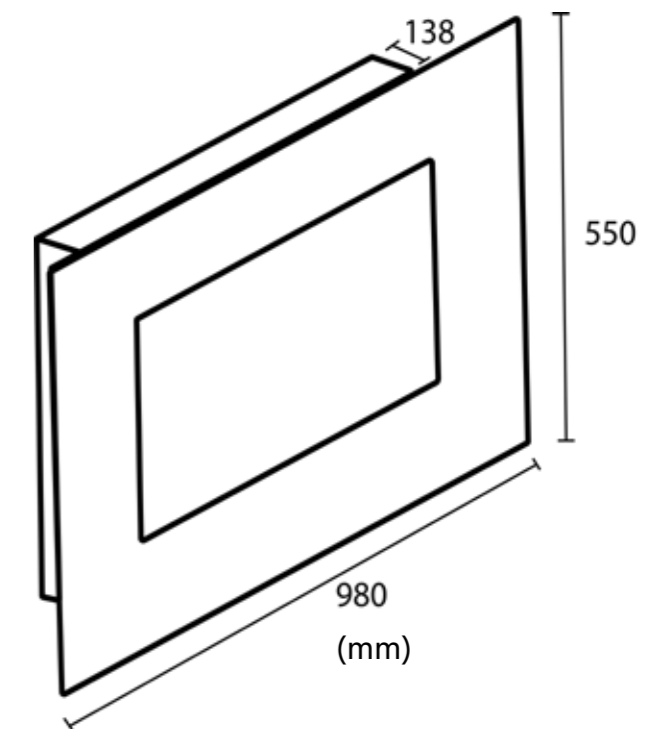

IT

Caminetto elettrico da parete modello Monte Bianco in acciaio e vetro. Potenza massima riscaldante 1500W. Realistico effetto fiamma LED regolabile in 6 livelli di intensità della luce. Telecomando a infrarossi incluso. Ottimo per casa e ufficio. Comandabile dal telecomando o dal display sul pannello di comando laterale.



EN

Wall-mounted electric fireplace model Mont Blanc in steel and glass. Maximum heating power 1500W. Realistic LED flame effect adjustable in 6 light intensity levels. Infrared remote control included. Great for home and office. Controllable from the remote control or the display on the side control panel.

FR

Cheminée électrique murale modèle Mont Blanc en acier et verre. Puissance de chauffage maximale de 1500W. Effet de flamme LED réaliste réglable sur 6 niveaux d'intensité lumineuse. Télécommande infrarouge incluse. Idéal pour la maison et le bureau. Contrôlable à partir de la télécommande ou de l'écran du panneau de commande latéral.

DE

Elektrischer Wandkamin Modell Mont Blanc aus Stahl und Glas. Maximale Heizleistung 1500W. Realistischer LED-Flammeneffekt in 6 Helligkeitsstufen einstellbar. Infrarot-Fernbedienung inklusive. Ideal für Haus und Büro. Die Steuerung erfolgt über die Fernbedienung oder das Display am seitlichen Bedienfeld.

ES

Chimenea eléctrica de pared modelo Mont Blanc en acero y cristal. Potencia máxima de calentamiento 1500W. Efecto de flama LED realista ajustable en 6 niveles de intensidad luminosa. Mando a distancia por infrarrojos incluido. Ideal para el hogar y la oficina. Se puede controlar desde el mando a distancia o la pantalla del panel de control lateral.

CAMINETTO-PARETE-STELVIO

8025431019232

128 CM



DIMENSIONI 128X55X14 CM
DIMENSIONS 128X55X14 CM

TIPO DI CALORE TERMOCONVETTORE 750-1500W
HEAT TYPE CONVECTOR 750-1500W

COLORE NERO
COLOUR BLACK

PESO 20,6 KG
WEIGHT 20,6 KG

**UNICI MODELLI IN EUROPA CERTIFICATI
 E TESTATI PER IL MONTAGGIO A
 PARETE.**
**THE ONLY MODELS IN EUROPE CERTIFIED
 AND TESTED FOR WALL MOUNTING.**



EU directives compliance
 LVD 2014/35/UE EMC 2014/30/UE
 DERP 2009/125/CE
 RoHS 2011/65/EU ((UE) 2015/863)

**DOPPIA MODALITA' DI
 FUNZIONAMENTO:
 DUAL MODE OF OPERATION:**

Solo effetto fiamma ultra realistico o riscaldante con motore PCT da 1500w sigillato ermeticamente. Vetro cristallo temperato. Pannello di controllo LCD frontale. Comandi manuali laterali, uscita e ingresso dell'aria sono posizionati nella parte superiore. Il caminetto è imballato in una scatola di cartone rinforzato.

ATTENZIONE! I caminetti da parete sono progettati per essere appesi alla parete. Non devono essere installati/incassati all'interno.

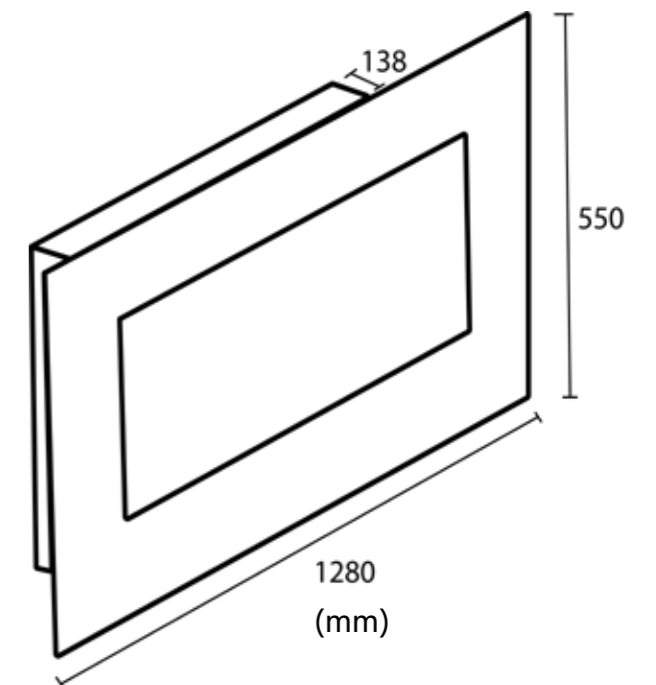

IT

Caminetto elettrico da parete modello Stelvio in acciaio e vetro. Potenza massima riscaldante 1500W. Realistico effetto fiamma LED regolabile in 6 livelli di intensità luce Telecomando incluso. Ottimo per casa ufficio, attività commerciali.. Comandabile dal telecomando o dal display sul pannello di comando laterale.



EN

Wall-mounted electric fireplace model Stelvio in steel and glass. Maximum heating power 1500W. Realistic LED flame effect adjustable in 6 light intensity levels Remote control included. Great for home office, business.. Controllable from the remote control or the display on the side control panel.

FR

Cheminée électrique murale modèle Stelvio en acier et verre. Puissance de chauffage maximale de 1500W. Effet de flamme LED réaliste réglable en 6 niveaux d'intensité lumineuse Télécommande incluse. Idéal pour le bureau à domicile, les affaires.. Contrôlable à partir de la télécommande ou de l'écran du panneau de commande latéral.

DE

Elektrischer Wandkamin Modell Stelvio aus Stahl und Glas. Maximale Heizleistung 1500W. Realistischer LED-Flammeneffekt, der in 6 Helligkeitsstufen einstellbar ist, inklusive Fernbedienung. Ideal für Heimbüro, Geschäft. Die Steuerung erfolgt über das Display am seitlichen Bedienfeld.

ES

Chimenea eléctrica de pared modelo Stelvio en acero y cristal. Potencia máxima de calentamiento 1500W. Efecto de llama LED realista ajustable en 6 niveles de intensidad de luz Mando a distancia incluido. Ideal para la oficina en casa, el negocio.. Se puede controlar desde el mando a distancia o la pantalla del panel de control lateral.

CAMINETTO-PARETE-APRICA

8025431019249

152 CM



DIMENSIONI 152X55X13,8 CM
DIMENSIONS 152X55X13,8 CM

TIPO DI CALORE TERMOCONVETTORE 750-1500W
HEAT TYPE CONVECTOR 750-1500W

COLORE NERO
COLOUR BLACK

PESO 24,1 KG
WEIGHT 24,1 KG

**UNICI MODELLI IN EUROPA CERTIFICATI
 E TESTATI PER IL MONTAGGIO A
 PARETE.
 THE ONLY MODELS IN EUROPE CERTIFIED
 AND TESTED FOR WALL MOUNTING.**

EU directives compliance
 LVD 2014/35/UE EMC 2014/30/UE
 DERP 2009/125/CE
 RoHS 2011/65/EU ((UE) 2015/863)



IT

Caminetto elettrico da parete modello Aprica in acciaio e vetro. Potenza massima riscaldante 1500W. Realistico effetto fiamma LED regolabile in 6 livelli di intensità della luce Telecomando a infrarossi incluso. Ottimo per casa e ufficio. Comandabile dal telecomando o dal display sul pannello di comando laterale.



EN

Aprica model wall-mounted electric fireplace in steel and glass. Maximum heating power 1500W. Realistic LED flame effect adjustable in 6 light intensity levels Infrared remote control included. Great for home and office. Controllable from the remote control or the display on the side control panel.

FR

Cheminée électrique murale modèle Aprica en acier et verre. Puissance de chauffage maximale de 1500W. Effet de flamme LED réaliste réglable sur 6 niveaux d'intensité lumineuse Télécommande infrarouge incluse. Idéal pour la maison et le bureau. Contrôlable à partir de la télécommande ou de l'écran du panneau de commande latéral.

DE

Elektrischer Wandkamin Modell Aprica aus Stahl und Glas. Maximale Heizleistung 1500W. Realistischer LED-Flammeneffekt in 6 Helligkeitsstufen einstellbar Infrarot-Fernbedienung inklusive. Ideal für Haus und Büro. Die Steuerung erfolgt über die Fernbedienung oder das Display am seitlichen Bedienfeld.

ES

Chimenea eléctrica de pared modelo Aprica de acero y cristal. Potencia máxima de calentamiento 1500W. Efecto de flama LED realista ajustable en 6 niveles de intensidad luminosa Mando a distancia por infrarrojos incluido. Ideal para el hogar y la oficina. Se puede controlar desde el mando a distancia o la pantalla del panel de control lateral.

DOPPIA MODALITA' DI FUNZIONAMENTO: DUAL MODE OF OPERATION:

Solo effetto fiamma ultra realistico o riscaldante con motore PCT da 1500w sigillato ermeticamente. Vetro cristallo temperato. Pannello di controllo LCD frontale. Comandi manuali laterali, uscita e ingresso dell'aria sono posizionati nella parte superiore. Il caminetto è imballato in una scatola di cartone rinforzato.

ATTENZIONE! I caminetti da parete sono progettati per essere appesi alla parete. Non devono essere installati/incassati all'interno.

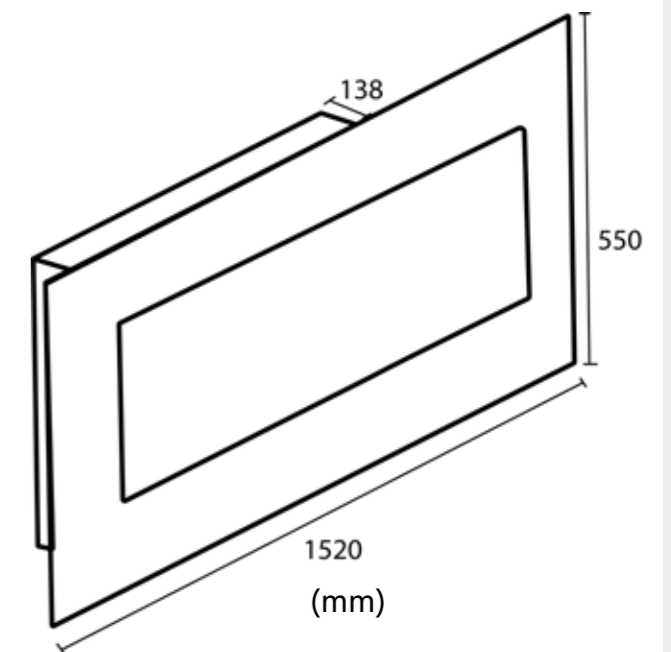

CAMINETTO-PARETE-PORDOI

8025431019256

183 CM



DIMENSIONI 182,5X55X13,9 CM
DIMENSIONS 182,5X55X13,9 CM

TIPO DI CALORE TERMOCONVETTORE 750-1500W
HEAT TYPE CONVECTOR 750-1500W

COLORE NERO
COLOUR BLACK

PESO 29,5 KG
WEIGHT 29,5 KG

**UNICI MODELLI IN EUROPA CERTIFICATI
 E TESTATI PER IL MONTAGGIO A
 PARETE.
 THE ONLY MODELS IN EUROPE CERTIFIED
 AND TESTED FOR WALL MOUNTING.v**



EU directives compliance
 LVD 2014/35/UE EMC 2014/30/UE
 DERP 2009/125/CE
 RoHS 2011/65/EU ((UE) 2015/863)

**DOPPIA MODALITA' DI
 FUNZIONAMENTO:
 DUAL MODE OF OPERATION:**

Solo effetto fiamma ultra realistico o riscaldante con motore PCT da 1500w sigillato ermeticamente. Vetro cristallo temperato. Pannello di controllo LCD frontale. Comandi manuali laterali, uscita e ingresso dell'aria sono posizionati nella parte superiore. Il caminetto è imballato in una scatola di cartone rinforzato.

ATTENZIONE! I caminetti da parete sono progettati per essere appesi alla parete. Non devono essere installati/incassati all'interno.

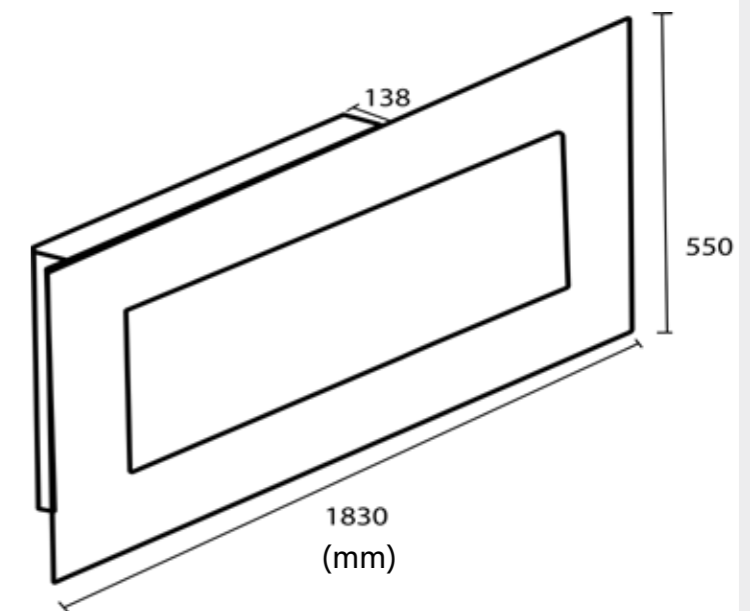

IT

Caminetto elettrico nero da parete modello Pordoi in acciaio e vetro. Potenza massima riscaldante 1500W. Realistico effetto fiamma LED regolabile in 6 livelli di intensità della luce Telecomando a infrarossi incluso. Ottimo per casa e ufficio. Comandabile dal telecomando o dal display sul pannello di comando laterale.



EN

Black electric wall-mounted fireplace model Pordoi in steel and glass. Maximum heating power 1500W. Realistic LED flame effect adjustable in 6 light intensity levels Infrared remote control included. Great for home and office. Controllable from the remote control or the display on the side control panel.

FR

Cheminée électrique murale noire modèle Pordoi en acier et verre. Puissance de chauffage maximale de 1500W. Effet de flamme LED réaliste réglable sur 6 niveaux d'intensité lumineuse Télécommande infrarouge incluse. Idéal pour la maison et le bureau. Contrôlable à partir de la télécommande ou de l'écran du panneau de commande latéral.

DE

Schwarzer elektrischer Wandkamin Modell Pordoi aus Stahl und Glas. Maximale Heizleistung 1500W. Realistischer LED-Flammeneffekt in 6 Helligkeitsstufen einstellbar Infrarot-Fernbedienung inklusive. Ideal für Haus und Büro. Die Steuerung erfolgt über die Fernbedienung oder das Display am seitlichen Bedienfeld.

ES

Chimenea eléctrica de pared negra modelo Pordoi de acero y cristal. Potencia máxima de calentamiento 1500W. Efecto de llama LED realista ajustable en 6 niveles de intensidad luminosa Mando a distancia por infrarrojos incluido. Ideal para el hogar y la oficina. Se puede controlar desde el mando a distancia o la pantalla del panel de control lateral.

CAMINETTI ELETTRICI A PAVIMENTO ELECTRIC FLOOR STANDING FIREPLACES

SINEDITALIA.COM

CATALOGO 2025

I caminetti da Pavimento Sined sono un elegante complemento per qualsiasi ambiente domestico, per la camera di un hotel o di un resort. Offrono il calore e l'atmosfera di una vera fiamma senza la necessità di combustibili tradizionali e di canne fumarie. Non sporcano come la legna e con il loro design moderno e raffinato, creano un'atmosfera accogliente e suggestiva, perfetta per rilassarsi e godersi momenti di tranquillità. Grazie alla loro praticità e facilità d'uso, rappresentano una soluzione ideale per riscaldare e abbellire gli spazi abitativi in modo innovativo.

They are an elegant addition to any home environment. They offer the warmth and atmosphere of a real flame without the need for traditional fuels. With their modern and refined design, they create a cosy and atmospheric atmosphere, perfect for relaxing and enjoying moments of tranquillity. Thanks to their practicality and ease of use, they represent an ideal solution for heating and beautifying living spaces in an innovative way.



CAMINO-ASCIANO

GRIGIO

8025431019003

RAL #7016



GRIGIO-SCURO

8025431019010



ROVERE

8025431019027



DIMENSIONI 88,3X99X25 CM
DIMENSIONS 88,3X99X25 CM

TIPO DI CALORE TERMOCONVETTORE 750-1500W
HEAT TYPE CONVECTOR 750-1500W

COLORE GRIGIO, GRIGIO SCURO, ROVERE
COLOUR GREY, DARK GREY, OAK

PESO 31,8 KG
WEIGHT 31,8 KG

**UNICI MODELLI IN EUROPA CERTIFICATI
E TESTATI PER INCASSO COMPLETO.
THE ONLY MODELS IN EUROPE THAT ARE
CERTIFIED AND TESTED FOR COMPLETE
EMBEDDING.**

EU directives compliance
LVD 2014/35/UE EMC 2014/30/UE
DERP 2009/125/CE
RoHS 2011/65/EU ((UE) 2015/863)

**DOPPIA MODALITA' DI
FUNZIONAMENTO:
DUAL MODE OF OPERATION:**

Solo effetto fiamma ultra realistico o riscaldante con motore PCT da 1500w sigillato ermeticamente. Vetro cristallo temperato. Pannello di controllo LCD frontale. Comandi manuali laterali, uscita e ingresso dell'aria sono posizionati nella parte superiore. Il caminetto è imballato in una scatola di cartone rinforzato.

ATTENZIONE! I caminetti da parete sono progettati per essere appesi alla parete. Non devono essere installati/incassati all'interno.

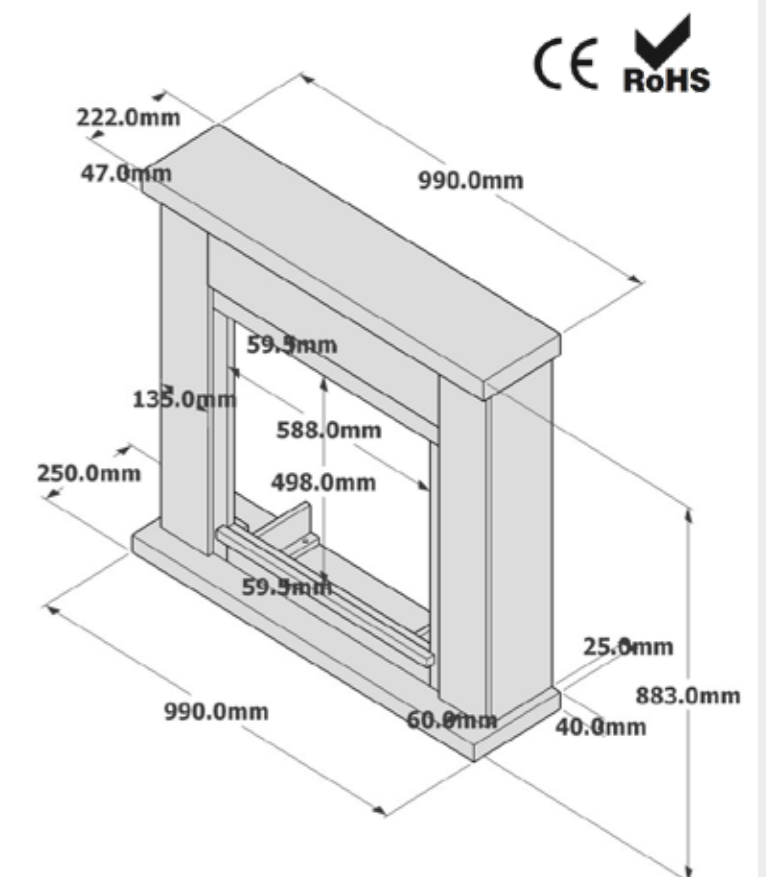

IT

Caminetto Elettrico Asciano Disponibile Con Varie Cornici Per Soddisfare Tutte Le Esigenze Di Arredamento. Potente Riscaldamento Da 1500w, Funzioni Regolabili Con Telecomando. Nessuna Canna Fumaria, Niente Polveri o Fuliggine, Nessuna Autorizzazione.



EN

Asciano Electric Fireplace Available With Various Frames To Meet All Decorating Needs. Powerful 1500w Heating, Adjustable Functions With Remote Control. No Chimney, No Dust Or Soot, No Permit.

FR

La Cheminée Électrique Asciano Est Disponible Avec Différents Cadres Pour Répondre à Toutes Les Exigences D'ameublement. Chauffage Puissant De 1500w, Fonctions Réglables Avec Télécommande. Pas De Cheminée, Pas De Poussière Ou De Suie, Pas De Permis.

DE

Der elektrische Kamin ASCIANO ist mit verschiedenen Rahmen erhältlich, um allen Einrichtungsanforderungen gerecht zu werden. Leistungsstarke 1500W Heizung, einstellbare Funktionen mit Fernbedienung. Kein Schornstein, kein Staub oder Ruß, keine Genehmigung.

ES

La Chimenea Eléctrica Asciano Está Disponible Con Varios Marcos Para Satisfacer Todas Las Necesidades De Mobiliario. Potente Calefacción De 1500w, Funciones Ajustables Con Mando a Distancia. Sin Chimenea, Sin Polvo Ni Hollín, Sin Permiso.

CAMINO-CALDERA

TURCHESE

8025431019478

RAL #5018



DIMENSIONI 102,2X114X28,2 CM
DIMENSIONS 102,2X114X28,2 CM

COLORE GRIGIO, TURCHESE
COLOUR GREY, TURQUOISE

GRIGIO

8025431019461

RAL #7016



TIPO DI CALORE TERMOCONVETTORE 750-1500W
HEAT TYPE CONVECTOR 750-1500W

PESO 37,3 KG
WEIGHT 37,3 KG

**UNICI MODELLI IN EUROPA CERTIFICATI
 E TESTATI PER INCASSO COMPLETO.
 THE ONLY MODELS IN EUROPE THAT ARE
 CERTIFIED AND TESTED FOR COMPLETE
 EMBEDDING.**

EU directives compliance
 LVD 2014/35/UE EMC 2014/30/UE
 DERP 2009/125/CE
 RoHS 2011/65/EU ((UE) 2015/863)

**DOPPIA MODALITA' DI
 FUNZIONAMENTO:
 DUAL MODE OF OPERATION:**

Solo effetto fiamma ultra realistico o riscaldante con motore PCT da 1500w sigillato ermeticamente. Vetro cristallo temperato. Pannello di controllo LCD frontale. Comandi manuali laterali, uscita e ingresso dell'aria sono posizionati nella parte superiore. Il caminetto è imballato in una scatola di cartone rinforzato.

ATTENZIONE! I caminetti da parete sono progettati per essere appesi alla parete. Non devono essere installati/incassati all'interno.

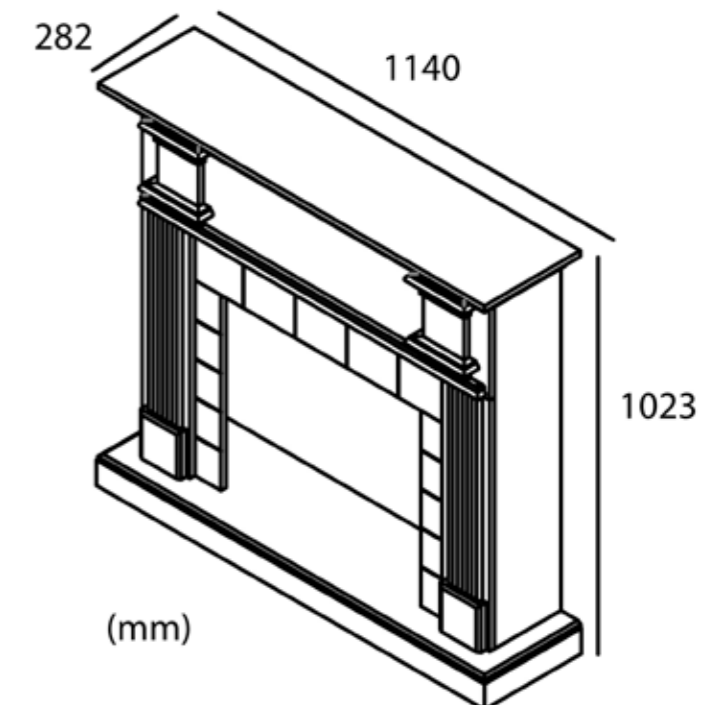

IT

Caminetto Elettrico Completo Di Inserto Elettrico 1500 w Effetto Fiamma Super Realisitco e Cornce In Legno Mdf Vari Colori. Telecomando Incluso, Possibile Utilizzare Il Solo Effetto Fiamma. Adatto Per Tutti Gli Ambienti Di Casae Ufficio.



EN

Electric Fireplace Complete With Electric Insert 1500 w Super Realisitc Flame Effect And Mdf Wood Cornce Various Colors. Remote Control Included, Possible To Use The Flame Effect Only. Suitable For All Home and Office Environments.

FR

Cheminée électrique complète avec insert électrique 1500 w à effet de flamme super réaliste et corniches en bois Mdf de différentes couleurs. Télécommande incluse, possibilité d'utiliser uniquement l'effet de flamme. Convient à tous les environnements domestiques et professionnels.

DE

Elektrischer Kamin komplett mit elektrischem Einsatz 1500 w Super Realisitc Flammeneffekt und Mdf Holz Cornce verschiedene Farben. Fernbedienung enthalten, möglich, nur den Flammeneffekt zu verwenden. Geeignet für alle Haus und Büro Umgebungen.

ES

Chimenea Electrica Completa Con Insertable Electrico 1500 w Efecto De Llama Super Realisitc Y Mdf Madera Cornce Varios Colores. Mando a distancia incluido, posible utilizar el efecto de la llama solamente. Adecuado para todos los ambientes del hogar y la oficina.



CAMINO-CETONA

NERO
8025431019133
RAL #9005



GRIGIO
8025431150973
RAL #7016



TURCHESE
8025431019140
RAL #5018



WENGHE
8025431019164



DIMENSIONI 102,2X114X28,2 CM
DIMENSIONS 102,2X114X28,2 CM

TIPO DI CALORE TERMOCONVETTORE 750-1500W
HEAT TYPE CONVECTOR 750-1500W

COLORE NERO, GRIGIO, TURCHESE, WENGHE
COLOUR BLACK, GREY, TURQUOISE, WENGE

PESO 37,3 KG
WEIGHT 37,3 KG

UNICI MODELLI IN EUROPA CERTIFICATI E TESTATI PER INCASSO COMPLETO. THE ONLY MODELS IN EUROPE THAT ARE CERTIFIED AND TESTED FOR COMPLETE EMBEDDING.

EU directives compliance
LVD 2014/35/UE EMC 2014/30/UE
DERP 2009/125/CE
RoHS 2011/65/EU ((UE) 2015/863)



DOPPIA MODALITA' DI FUNZIONAMENTO: DUAL MODE OF OPERATION:

Solo effetto fiamma ultra realistico o riscaldante con motore PCT da 1500w sigillato ermeticamente. Vetro cristallo temperato. Pannello di controllo LCD frontale. Comandi manuali laterali, uscita e ingresso dell'aria sono posizionati nella parte superiore. Il caminetto è imballato in una scatola di cartone rinforzato.

ATTENZIONE! I caminetti da parete sono progettati per essere appesi alla parete. Non devono essere installati/incassati all'interno.

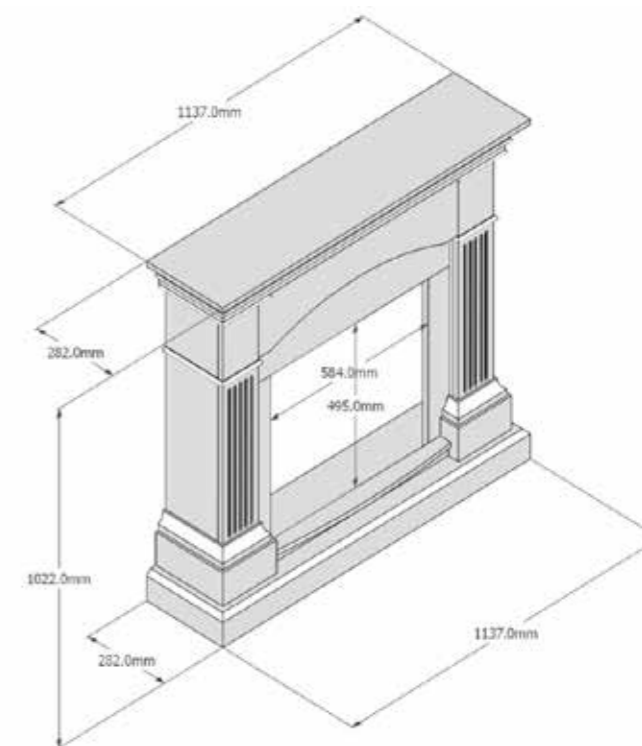

IT

Caminetto Cetona, Esclusivo Nel Design e Colori. Questa Serie Di Caminetti Elettrici Completi Evocano La Toscana Con Classe. Materiali Di Ottima Qualità Che Assicurano Durata e Minima Manutenzione Nel Tempo. Sconto Subito Al Momento Dell'ordine.



EN

Cetona Fireplace, Exclusive In Design And Colour. This Series Of Complete Electric Fireplaces Evokes Tuscany With Class. High-quality materials ensure durability and minimal maintenance. Discount Immediately Upon Order.

FR

Cheminée Cetona, au design et à la couleur exclusifs. Cette série de cheminées électriques complètes évoque la Toscane avec classe. Les matériaux de haute qualité garantissent la durabilité et un entretien minimal. Remise immédiate à la commande.

DE

Cetona-Kamin, exklusiv in Design und Farbe. Diese Serie kompletter elektrischer Kamine erinnert an die Toscana mit Klasse. Hochwertige Materialien garantieren Langlebigkeit und minimale Wartung. Rabatt sofort bei Bestellung.

ES

Chimenea Cetona, Exclusiva en Diseño y Color. Esta Serie De Chimeneas Eléctricas Completas Evoca La Toscana Con Clase. Los materiales de alta calidad garantizan durabilidad y un mantenimiento mínimo. Descuento Inmediato Al Realizar El Pedido.

CAMINO-LIPARI

GRIGIO

8025431019508

RAL #7016

NERO

8025431019492

RAL #9005

TURCHESE

8025431019515

RAL #5018



DIMENSIONI 95X109X21,5 CM
DIMENSIONS 95X109X21,5 CM

TIPO DI CALORE TERMOCONVETTORE 750-1500W
HEAT TYPE CONVECTOR 750-1500W

COLORE GRIGIO, NERO, TURCHESE
COLOUR GREY, BLACK, TURQUOISE

PESO 37,3 KG
WEIGHT 37,3 KG

**UNICI MODELLI IN EUROPA CERTIFICATI
 E TESTATI PER INCASSO COMPLETO.
 THE ONLY MODELS IN EUROPE THAT ARE
 CERTIFIED AND TESTED FOR COMPLETE
 EMBEDDING.**



EU directives compliance
 LVD 2014/35/UE EMC 2014/30/UE
 DERP 2009/125/CE
 RoHS 2011/65/EU ((UE) 2015/863)

**DOPPIA MODALITA' DI
 FUNZIONAMENTO:
 DUAL MODE OF OPERATION:**

Solo effetto fiamma ultra realistico o riscaldante con motore PCT da 1500w sigillato ermeticamente. Vetro cristallo temperato. Pannello di controllo LCD frontale. Comandi manuali laterali, uscita e ingresso dell'aria sono posizionati nella parte superiore. Il caminetto è imballato in una scatola di cartone rinforzato.

ATTENZIONE! I caminetti da parete sono progettati per essere appesi alla parete. Non devono essere installati/incassati all'interno.

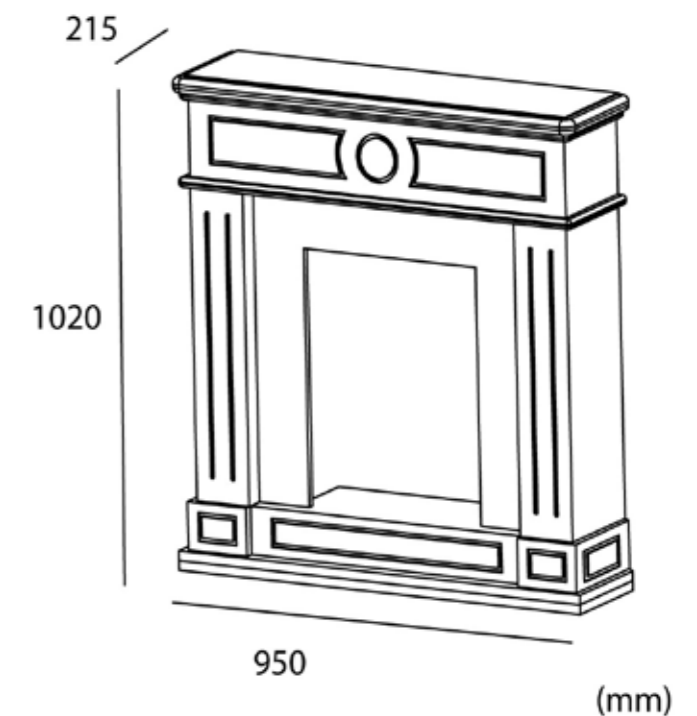

IT

Caminetto Elettrico Completo Di Inserto Elettrico 1500 w Effetto Fiamma Super Realisitico e Cornice In Legno Mdf Grigio Scuro. Caminetto Design Completo Di Telecomando. Realizzato In Legno Mdf Di Alta Qualità Facile Da Posizionare o Spostare.



EN

Electric Fireplace Complete With Electric Insert 1500 w Super Realisitc Flame Effect and Dark Grey Mdf Wood Frame. Design Fireplace Complete With Remote Control. Made of High Quality Mdf Wood Easy to place or move.

FR

Cheminée électrique complète avec insert électrique 1500 w à effet de flamme super réaliste et cadre en bois Mdf gris foncé. Foyer design avec télécommande. Fabriquée en bois Mdf de haute qualité. Facile à placer ou à déplacer.

DE

Elektrokamin komplett mit Elektroinsert 1500 mit super realistischem Flammeneffekt und dunkelgrauem Mdf-Holzrahmen. Design-Kamin komplett mit Fernbedienung. Hergestellt aus hochwertigem Mdf Holz Einfach zu platzieren oder zu bewegen.

ES

Chimenea electrica completa con inserto electrico 1500 w Super Realisitc efecto de la llama y el marco de madera gris oscuro Mdf. Chimenea de diseño con mando a distancia. Hecho de madera MDF de alta calidad. Fácil de colocar o mover.

CAMINO-PIENZA-TURCHESE

8025431019584

RAL #5018



DIMENSIONI 94,9X110X24,9 CM
DIMENSIONS 94,9X110X24,9 CM

TIPO DI CALORE TERMOCONVETTORE 750-1500W
HEAT TYPE CONVECTOR 750-1500W

COLORE TURCHESE
COLOUR TURQUOISE

PESO 32,2 KG
WEIGHT 32,2 KG

**UNICI MODELLI IN EUROPA CERTIFICATI
 E TESTATI PER INCASSO COMPLETO.
 THE ONLY MODELS IN EUROPE THAT ARE
 CERTIFIED AND TESTED FOR COMPLETE
 EMBEDDING.**



EU directives compliance
 LVD 2014/35/UE EMC 2014/30/UE
 DERP 2009/125/CE
 RoHS 2011/65/EU ((UE) 2015/863)

**DOPPIA MODALITA' DI
 FUNZIONAMENTO:
 DUAL MODE OF OPERATION:**

Solo effetto fiamma ultra realistico o riscaldante con motore PCT da 1500w sigillato ermeticamente. Vetro cristallo temperato. Pannello di controllo LCD frontale. Comandi manuali laterali, uscita e ingresso dell'aria sono posizionati nella parte superiore. Il caminetto è imballato in una scatola di cartone rinforzato.

ATTENZIONE! I caminetti da parete sono progettati per essere appesi alla parete. Non devono essere installati/incassati all'interno.

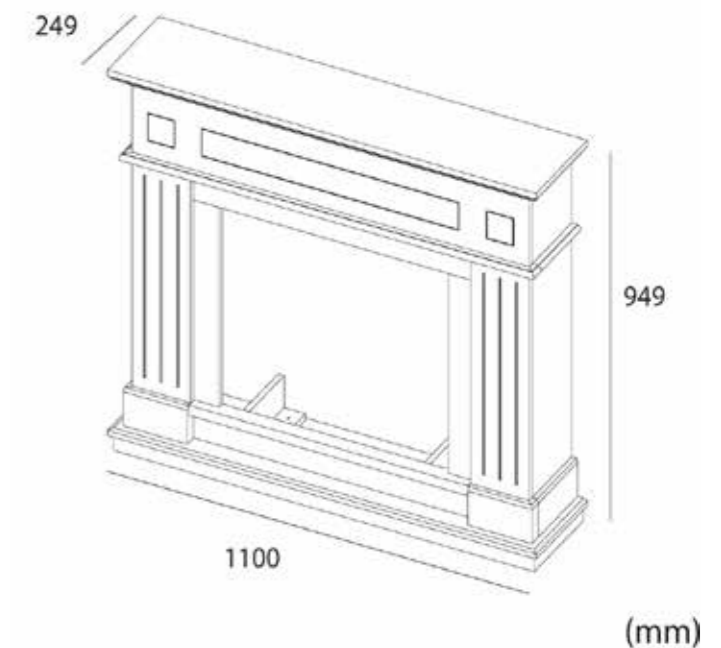

(mm)



IT

Caminetto Da Terra e Parete Per Ufficio. Composto Da Cornice Turchese e Bruciatore Elettrico Nero 1500w Con Reale Effetto Fiamma Led. Caminetto Design Completo Di Telecomando. Realizzato In Legno Mdf Di Alta Qualità Facile Da Posizionare o Spostare.



EN

Floor and Wall Office Fireplace. Consisting of Turquoise Frame and Black Electric Burner 1500w With Real Led Flame Effect. Design Fireplace Complete With Remote Control. Made of High Quality Mdf Wood. Easy to place or move.

FR

Cheminée de bureau pour le sol et le mur. Composée d'un cadre turquoise et d'un brûleur électrique noir 1500w avec effet de flamme LED. Foyer design avec télécommande. Fabriquée en bois Mdf de haute qualité, elle est facile à placer ou à déplacer.

DE

Boden und Wand Büro-Kamin. Bestehend aus türkischem Rahmen und schwarzem Elektrobrenner 1500w mit echtem Led-Flammeneffekt. Design-Kamin komplett mit Fernbedienung. Hergestellt aus hochwertigem Mdf Holz. leicht zu platzieren oder zu bewegen.

ES

Chimenea de oficina de suelo y pared. Consta de Marco Turquesa y Quemador Eléctrico Negro 1500w Con Efecto de Llama Real Led. Chimenea de diseño con mando a distancia. Fabricada en Madera Mdf de Alta Calidad. Fácil de Colocar o Trasladar.

CAMINO-SIENA

BIANCO-CREMA
S025431019089



BEIGE
S025431019072



ROVERE
S025431019102



GRIGIO-SCURO
S025431019096



WENGE
S025431019119



DIMENSIONI 95,2X107,2X24,5 CM
DIMENSIONS 95,2X107,2X24,5 CM

TIPO DI CALORE TERMOCONVETTORE 750-1500W
HEAT TYPE CONVECTOR 750-1500W

COLORE BIANCO-CREMA, BEIGE, GRIGIO-SCURO, ROVERE, WENGE
COLOUR CREAM-WHITE, BEIGE, DARK-GREY, OAK, WENGE

PESO 37,3 KG
WEIGHT 37,3 KG

**UNICI MODELLI IN EUROPA CERTIFICATI
E TESTATI PER INCASSO COMPLETO.
THE ONLY MODELS IN EUROPE THAT ARE
CERTIFIED AND TESTED FOR COMPLETE
EMBEDDING.**

EU directives compliance
LVD 2014/35/UE EMC 2014/30/UE
DERP 2009/125/CE
RoHS 2011/65/EU ((UE) 2015/863)

**DOPPIA MODALITA' DI
FUNZIONAMENTO:
DUAL MODE OF OPERATION:**

Solo effetto fiamma ultra realistico o riscaldante con motore PCT da 1500w sigillato ermeticamente. Vetro cristallo temperato. Pannello di controllo LCD frontale. Comandi manuali laterali, uscita e ingresso dell'aria sono posizionati nella parte superiore. Il caminetto è imballato in una scatola di cartone rinforzato.

ATTENZIONE! I caminetti da parete sono progettati per essere appesi alla parete. Non devono essere installati/incassati all'interno.

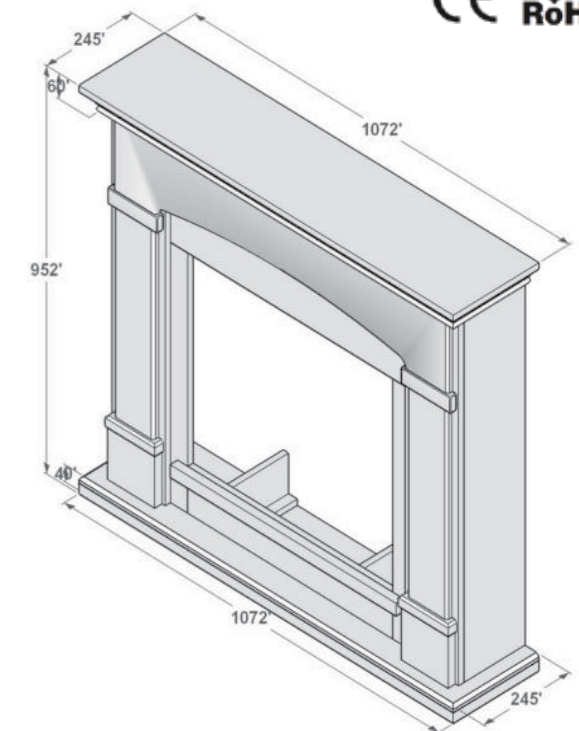

IT

Benvenuto! Scegli Un Caminetto Da Terra Della Serie Siena. Composto Da Cornice e Bruciatore Elettrico 1500w, Reale Effetto Fiamma Led. Caminetto Completo Di Telecomando. Realizzato In Legno Mdf Di Alta Qualità Facile Da Posizionare o Spostare.



EN

Welcome! Choose an In-ground Fireplace from the Siena Series. Composed Of Frame and Electric Burner 1500w, Real Led Flame Effect. Fireplace Complete With Remote Control. Made of High Quality Mdf Wood. Easy to place or move.

FR

Bienvenue ! Choisissez un foyer encastré de la série Siena. Composé d'un cadre et d'un brûleur électrique de 1500w, avec effet de flamme LED. Foyer complet avec télécommande. Fabriqué en bois Mdf de haute qualité, facile à placer ou à déplacer.

DE

Willkommen! Wählen Sie einen Unterflurkamin aus der Siena-Serie. Bestehend aus Rahmen und elektrischem Brenner 1500w, echter Led-Flammeneffekt. Kamin komplett mit Fernbedienung. Hergestellt aus hochwertigem Mdf Holz, leicht zu platzieren oder zu bewegen.

ES

¡Bienvenido! Elija una Chimenea Empotrada de la Serie Siena. Compuesto De Marco Y Quemador Eléctrico 1500w, Efecto De Llama Led Real. Chimenea Completa Con Mando A Distancia. Hecho De Madera Mdf De Alta Calidad. Fácil De Colocar O Mover.

CAMINO-SORANO-GRIGIO-SCURO

8025431019195



DIMENSIONI 67,8X75X24,5 CM
DIMENSIONS 67,8X75X24,5 CM

TIPO DI CALORE TERMOCONVETTORE 750-1500W
HEAT TYPE CONVECTOR 750-1500W

COLORE GRIGIO SCURO
COLOUR DARK-GREY

PESO 21,2 KG
WEIGHT 21,2 KG

**UNICI MODELLI IN EUROPA CERTIFICATI
 E TESTATI PER INCASSO COMPLETO.
 THE ONLY MODELS IN EUROPE THAT ARE
 CERTIFIED AND TESTED FOR COMPLETE
 EMBEDDING.**

EU directives compliance
 LVD 2014/35/UE EMC 2014/30/UE
 DERP 2009/125/CE
 RoHS 2011/65/EU ((UE) 2015/863)

**DOPPIA MODALITA' DI
 FUNZIONAMENTO:
 DUAL MODE OF OPERATION:**

Solo effetto fiamma ultra realistico o riscaldante con motore PCT da 1500w sigillato ermeticamente. Vetro cristallo temperato. Pannello di controllo LCD frontale. Comandi manuali laterali, uscita e ingresso dell'aria sono posizionati nella parte superiore. Il caminetto è imballato in una scatola di cartone rinforzato.

ATTENZIONE! I caminetti da parete sono progettati per essere appesi alla parete. Non devono essere installati/incassati all'interno.

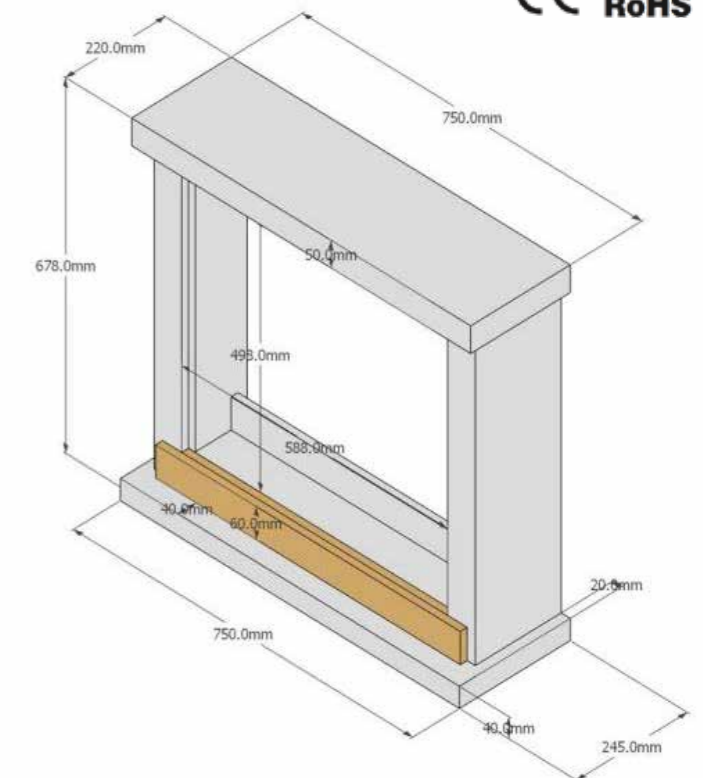

IT

Caminetto Grigio Scuro Per Pavimento e Parete Composto Da Cornice e Bruciatore Elettrico Nero 1500w Con Reale Effetto Fiamma Led. Caminetto Design Completo Di Telecomando. Realizzato In Legno Mdf Di Alta Qualità Facile Da Posizionare o Spostare.



EN

Dark Grey Fireplace For Floor And Wall Composed Of Frame And Black Electric Burner 1500w With Real Led Flame Effect. Design Fireplace Complete With Remote Control. Made of High Quality Mdf Wood. Easy to place or move.

FR

Foyer gris foncé pour sol et mur composé d'un cadre et d'un brûleur électrique noir 1500w avec effet de flamme LED. Cheminée design avec télécommande. Fabriquée en bois Mdf de haute qualité, elle est facile à placer ou à déplacer.

DE

Dunkelgrauer Kamin für Boden und Wand, bestehend aus Rahmen und schwarzem Elektrobrenner 1500w mit echtem Led-Flammeneffekt. Design-Kamin komplett mit Fernbedienung. Hergestellt aus hochwertigem Mdf Holz. leicht zu platzieren oder zu bewegen.

ES

Chimenea Gris Oscuro Para Suelo Y Pared Compuesta De Marco Y Quemador Electrico Negro 1500w Con Efecto De Llama Real Led. Chimenea De Diseño Completa Con Mando A Distancia. Hecho De Madera Mdf De Alta Calidad. Fácil De Colocar O Mover.

SOLO CORNICI

FIREPLACE FRAMES

Le cornici per camini di SINED sono il tocco finale perfetto per abbellire qualsiasi casa. Progettate con attenzione ai dettagli e realizzate con materiali di alta qualità, le nostre cornici offrono una varietà di stili, dal classico al contemporaneo, per completare qualsiasi arredamento d'interni. Con finiture eleganti e durevoli, le nostre cornici non solo esaltano l'estetica del tuo camino, ma aggiungono anche un elemento di distinzione e sofisticazione al tuo spazio. Affidati a SINED per un design superiore che combina funzionalità e bellezza in ogni pezzo.

SINED's fireplace cornices are the perfect finishing touch to enhance any home. Designed with attention to detail and crafted from high-quality materials, our cornices offer a variety of styles, from classic to contemporary, to complement any interior décor. With elegant and durable finishes, our cornices not only enhance the aesthetics of your fireplace but also add an element of distinction and sophistication to your space. Trust SINED for superior design that combines functionality and beauty in every piece.



CORNICE-CAMINO-CALDERA

GRIGIO

8025431019386

RAL #7016



DIMENSIONI 102,2X114X28,2 CM
DIMENSIONS 102,2X114X28,2 CM

COLORE GRIGIO, TURCHESE
COLOUR GREY, TURQUOISE

PESO 30 KG
WEIGHT 30 KG

TURCHESE

8025431019393

RAL #5018



COSTRUZIONE DI QUALITÀ SUPERIORE IN
LEGNO MDF CERTIFICATO E VERNICIATURA
ATOSSICA A BASE D'ACQUA.
SUPERIOR CONSTRUCTION IN CERTIFIED MDF
WOOD AND NON-TOXIC WATER-BASED PAINT.

GARANTISCE SEMPLICITÀ DI MONTAGGIO,
DURATA NEL TEMPO E RESISTENZA
STRUTTURALE.
GUARANTEES EASY ASSEMBLY, DURABILITY
AND STRUCTURAL STRENGTH.

IT

Cornici per Caminetti da pavimento modello Caldera, disponibile in vari colori. Cornice in stile classico modello Caldera per caminetto elettrico. Stile classico, dalle linee geometriche pulite
Cornice per camino elettrico della collezione abbinabile con il caminetto elettrico VULCANO.

EN

Floor standing fireplace frames model Caldera, available in various colours. Classic style Caldera model frame for electric fireplace. Classic style, with clean geometric lines
Picture frame for electric fireplace from the collection that can be combined with the VULCANO electric fireplace.



CORNICE-CAMINO-CETONA

GRIGIO

8025431019331

RAL #7016



DIMENSIONI 102,2X113,7X28,2 CM
DIMENSIONS 102,2X113,7X28,2 CM

COLORE GRIGIO, NERO, TURCHESE
COLOUR GREY, BLACK, TURQUOISE

PESO 32 KG
WEIGHT 32 KG

NERO

8025431019348

RAL #9005



COSTRUZIONE DI QUALITÀ SUPERIORE IN
LEGNO MDF CERTIFICATO E VERNICIATURA
ATOSSICA A BASE D'ACQUA.
SUPERIOR CONSTRUCTION IN CERTIFIED MDF
WOOD AND NON-TOXIC WATER-BASED PAINT.

GARANTISCE SEMPLICITÀ DI MONTAGGIO,
DURATA NEL TEMPO E RESISTENZA
STRUTTURALE.
GUARANTEES EASY ASSEMBLY, DURABILITY
AND STRUCTURAL STRENGTH.

IT

Cornice per Caminetto da pavimento modello CETONA colore grigio scuro Cornice in stile classico per caminetto elettrico. Stile classico, dalle linee geometriche pulite
Cornice per camino elettrico della collezione CETONA abbinabile con il caminetto elettrico VULCANO.

EN

CETONA model floor standing fireplace frame dark grey Classic style frame for electric fireplace. Classic style, with clean geometrical lines
Frame for electric fireplace from the CETONA collection that can be combined with the VULCANO electric fireplace.



CORNICE-CAMINO-LIPARI

GRIGIO

8025431019423
RAL #7016



NERO

8025431019416
RAL #9005



TURCHESE

8025431019430
RAL #5018



DIMENSIONI 95X109X21,5 CM
DIMENSIONS 95X109X21,5 CM

COLORE GRIGIO, NERO, TURCHESE
COLOUR GREY, BLACK, TURQUOISE

PESO 30 KG
WEIGHT 30 KG

COSTRUZIONE DI QUALITÀ SUPERIORE IN
LEGNO MDF CERTIFICATO E VERNICIATURA
ATOSSICA A BASE D'ACQUA.
SUPERIOR CONSTRUCTION IN CERTIFIED MDF
WOOD AND NON-TOXIC WATER-BASED PAINT.

GARANTISCE SEMPLICITÀ DI MONTAGGIO,
DURATA NEL TEMPO E RESISTENZA
STRUTTURALE.
GUARANTEES EASY ASSEMBLY, DURABILITY
AND STRUCTURAL STRENGTH.

IT

Cornice per Caminetto da pavimento modello Lipari, colore blu turchese. Cornice in stile lineare modello serie Lipari per caminetto elettrico. Ideale per tutti gli ambienti interni. Design lineare, dalle linee geometriche pulite. Cornice per camino elettrico della collezione Lipari abbinabile con il caminetto elettrico VULCANO.

EN

Lipari model floor-standing fireplace frame, turquoise blue. Linear style frame model series Lipari for electric fireplace. Ideal for all interiors. Linear design, with clean geometric lines Lipari collection electric fireplace frame that can be combined with the VULCANO electric fireplace.



CORNICE-CAMINO-PIENZA

NERO

8025431019300
RAL #9005



GRIGIO

8025431019294
RAL #7016



TURCHESE

8025431019317
RAL #5018



DIMENSIONI 94,9X110X24,9 CM
DIMENSIONS 94,9X110X24,9 CM

COLORE GRIGIO, NERO, TURCHESE
COLOUR GREY, BLACK, TURQUOISE

PESO 22,8 KG
WEIGHT 22,8 KG

COSTRUZIONE DI QUALITÀ SUPERIORE IN
LEGNO MDF CERTIFICATO E VERNICIATURA
ATOSSICA A BASE D'ACQUA.
SUPERIOR CONSTRUCTION IN CERTIFIED MDF
WOOD AND NON-TOXIC WATER-BASED PAINT.

GARANTISCE SEMPLICITÀ DI MONTAGGIO,
DURATA NEL TEMPO E RESISTENZA
STRUTTURALE.
GUARANTEES EASY ASSEMBLY, DURABILITY
AND STRUCTURAL STRENGTH.

IT

Cornice per Caminetto da pavimento modello Pienza, in vari colori. Cornice in stile classico modello Pienza per caminetto elettrico, ottimo per casa e ufficio. Stile classico, dalle linee geometriche pulite. Cornice per camino elettrico della collezione abbinabile con il caminetto elettrico VULCANO.

EN

Cornice per Caminetto da pavimento modello Pienza, in vari colori. Classic style Pienza model frame for electric fireplace, excellent for home and office. Classic style, with clean geometric lines. Frame for electric fireplace from the collection that can be combined with the VULCANO electric fireplace.



RISCALDATORI A INFRAROSSI

INFRARED HEATERS

I riscaldatori infrarossi SINED offrono una soluzione di riscaldamento efficiente ed ecologica per qualsiasi ambiente. Utilizzando la tecnologia a infrarossi, questi riscaldatori forniscono calore diretto e uniforme, creando un comfort immediato senza dispersione di energia. Ideali per uso interno ed esterno, i riscaldatori infrarossi SINED sono progettati con materiali di alta qualità e un design elegante, garantendo non solo performance eccellenti ma anche un'estetica piacevole. Affidabili e facili da usare, rappresentano la scelta perfetta per un riscaldamento rapido ed efficiente.

SINED infrared heaters offer an efficient and eco-friendly heating solution for any environment. Using infrared technology, these heaters provide direct and even heat, creating immediate comfort without energy loss. Ideal for both indoor and outdoor use, SINED infrared heaters are designed with high-quality materials and an elegant design, ensuring not only excellent performance but also an attractive aesthetic. Reliable and easy to use, they are the perfect choice for quick and efficient heating.



CALDO-I-BOX

8025431016569



DIMENSIONI 60,2X25X12 CM
DIMENSIONS 60,2X25X12 CM

COLORE ARGENTO
COLOUR SILVER

TIPO DI CALORE ONDA CORTA IR-A
HEAT TYPE SHORT WAVE IR-A

PESO 2,9 KG
WEIGHT 2,9 KG

EU directives compliance
LVD 2014/35/UE EMC 2014/30/UE
DERP 2009/125/CE
RoHS 2011/65/EU ((UE) 2015/863)



IT

Riscaldatore a infrarossi speciale moderno e ottimizzato per bar e dehors con potenza da 2000W regolabile. La struttura è realizzata in acciaio e alluminio resistenti alla corrosione. Il grado di protezione del riscaldatore infrarossi area commerciale è di IP65 che rende questo prodotto adatto a tutti i climi.

EN

Special modern infrared heater optimized for bars and dehors with 2000W adjustable power. The structure is made of corrosion resistant steel and aluminum. The degree of protection of the infrared heater commercial area is IP65 which makes this product suitable for all climates.

FR

Réchauffeur infrarouge moderne spécial optimisé pour les bars et les terrasses avec une puissance réglable de 2000W. La structure est faite d'acier et d'aluminium résistant à la corrosion. Le degré de protection du chauffage infrarouge pour zone commerciale est IP65, ce qui rend ce produit adapté à tous les climats.

DE

Spezieller moderner Infrarotstrahler, optimiert für Bars und Terrassen mit 2000W regelbarer Leistung. Die Struktur ist aus korrosionsbeständigem Stahl und Aluminium gefertigt. Die Schutzart dieser Infrarot-Heizung für Heim und Gewerbe ist IP65, was dieses Produkt für alle Klimazonen geeignet macht.

ES

Calentador de infrarrojos especial y moderno optimizado para bares y terrazas con una potencia regulable de 2000W. La estructura es de acero y aluminio resistente a la corrosión. El grado de protección del calentador infrarrojo de área comercial es IP65 lo que hace que este producto sea adecuado para todos los climas.

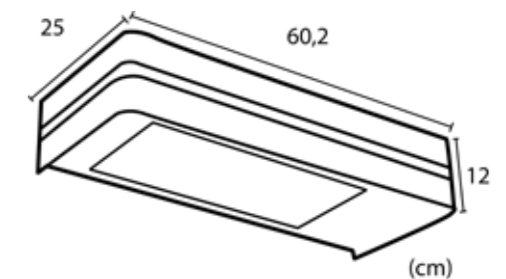
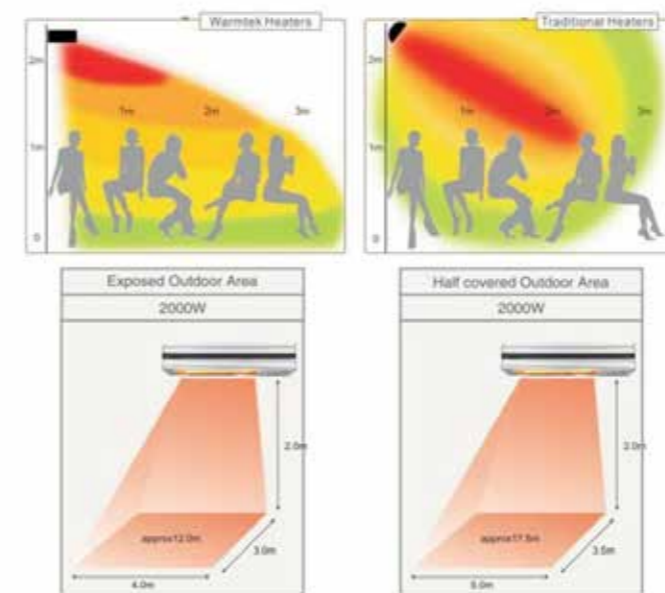



CALDO-IRA-INOX-2000

8025431016576

CALDO-IRA-INOX-2000-WIFI

8025431018822



DIMENSIONI 74,2X218X13,9 CM
DIMENSIONS 74,2X218X13,9 CM

TIPO DI CALORE ONDA CORTA IR-A
HEAT TYPE SHORT WAVE IR-A

COLORE ARGENTO
COLOUR SILVER

PESO 2,9 KG
WEIGHT 2,9 KG

EU directives compliance
LVD 2014/35/UE EMC 2014/30/UE
DERP 2009/125/CE
RoHS 2011/65/EU ((UE) 2015/863)



IT

Stufa a infrarossi da esterno con potenza 2000W regolabile a 3 livelli 100%, 66% e 33%. Struttura realizzata in alluminio anodizzato e acciaio con griglia di protezione e display a led.

Riscaldatore elettrico infrarossi a onda corta IR-A e telecomando, dispone di un grado di protezione impermeabile IP65 per ambienti esterni.

EN

Outdoor infrared heater with 2000W power adjustable to 3 levels 100%, 66 33%. Structure made of anodized aluminium and steel with protection grid and led display.

Short wave infrared electric heater IR-A and remote control, it has a waterproof protection degree IP65 for outdoor.

FR

Chauffage infrarouge extérieur avec une puissance de 2000W réglable sur 3 niveaux 100%, 66 33%. Structure en aluminium anodisé et acier avec grille de protection et affichage à leds.

Chauffeur électrique infrarouge à ondes courtes IR-A et télécommande, il possède un degré de protection étanche IP65 pour l'extérieur et l'intérieur.

DE

Infrarot-Heizung für Außenbereiche mit 2000 W Leistung, einstellbar auf 3 Stufen 100%, 66% oder 33%. Struktur aus eloxiertem Aluminium und Stahl mit Schutzgitter und LED-Anzeige.

Kurzwellen-Infrarot-Elektroheizung IR-A mit Fernbedienung und Schutzgrad IP65 für Aussen.

ES

Calentador infrarrojo para exterior con 2000W de potencia ajustable a 3 niveles 100%, 66 33%. Estructura de aluminio anodizado y acero con rejilla de protección y pantalla de leds.

Calentador eléctrico de onda corta IR-A y mando a distancia, tiene un grado de protección impermeable IP65 para exteriores e interiores.

LAMPADA A BASSO ABBAGLIAMENTO E ANTIRIFLESSO LOW GLARE AND ANTI-REFLECTION LAMP

CONTROL VIA SMARTPHONE WIFI MODEL ONLY

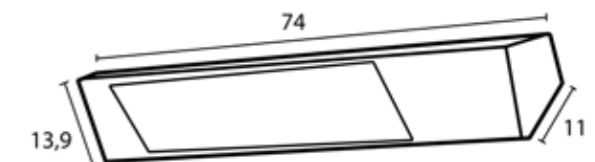

CALDO-VETRO-NERO-2000

8025431012233

CALDO-VETRO-NERO-2000-WIFI 

8025431018846

**DIMENSIONI** 13,9X11X74,2 CM**DIMENSIONS** 13,9X11X74,2 CM**COLORE NERO****COLOUR BLACK****TIPO DI CALORE ONDA CORTA IR-A**
HEAT TYPE SHORT WAVE IR-A

EU directives compliance

LVD 2014/35/UE EMC 2014/30/UE

DERP 2009/125/CE

RoHS 2011/65/EU ((UE) 2015/863)

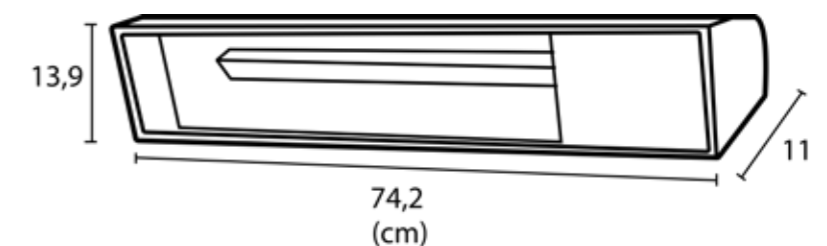
PESO 3,2 KG**WEIGHT 3,2 KG****VETRO BLACK SCHOTT RIDUCE L'EMISSIONE DI LUCE E RADIAZIONI NOCIVE.****BLACK SCHOTT GLASS REDUCES THE EMISSION OF LIGHT AND HARMFUL RADIATION.****CONTROLLO TRAMITE SMARTPHONE SOLO MODELLO WIFI**
CONTROL VIA SMARTPHONE WIFI MODEL ONLY**LAMPADA RISCALDANTE LOW GLARING**
LOW GLARING HEATING LAMP.**IT**

Riscaldatore infrarossi con vetro in ceramica brevettato Black Schott. Questo vetro è particolarmente adatta per esterno grazie alla sua resistenza al calore e agli shock termici, alle corrosioni e alle intemperie. Riduce inoltre l'abbagliamento luminoso che può essere un problema pericoloso e fastidioso.

EN

Infrared heater with patented Black Schott ceramic glass. This glass is particularly suitable for outdoors due to its resistance to heat and thermal shock, corrosion and weathering. It also reduces light glare, which can be a dangerous and annoying problem.

FR

Réchauffeur infrarouge avec verre céramique Black Schott breveté. Ce verre est particulièrement adapté à l'extérieur en raison de sa résistance à la chaleur et aux chocs thermiques, à la corrosion et aux intempéries. Il réduit également l'éblouissement, qui peut être un problème dangereux et gênant.

DE

Infrarotheizung mit patentiertem Black Schott Keramikglas. Dieses Glas ist aufgrund seiner Hitze- und Temperaturwechselbeständigkeit, seiner Korrosions- und Witterungsbeständigkeit besonders für den Außenbereich geeignet. Außerdem wird die Blendung durch Licht reduziert, die ein gefährliches und lästiges Problem darstellen kann.

ES

Calentador de infrarrojos especial y moderno optimizado para bares y terrazas con una potencia regulable de 2000W. La estructura es de acero y aluminio resistente a la corrosión. El grado de protección del calentador infrarrojo de área comercial es IP65 lo que hace que este producto sea adecuado para todos los climas.

STUFA-INFRAROSSI-PARETE-2000

8025431012295



DIMENSIONI 64X19X41 CM
DIMENSIONS 64X19X41 CM

TIPO DI CALORE ONDA CORTA IR-A
HEAT TYPE SHORT WAVE IR-A

COLORE GRIGIO
COLOUR GREY

PESO 3,8 KG
WEIGHT 3,8 KG

EU directives compliance
 LVD 2014/35/UE EMC 2014/30/UE
 DERP 2009/125/CE
 RoHS 2011/65/EU ((UE) 2015/863)



**LAMPADA RISCALDANTE LOW
 GLARING**
LOW GLARING HEATING LAMP.

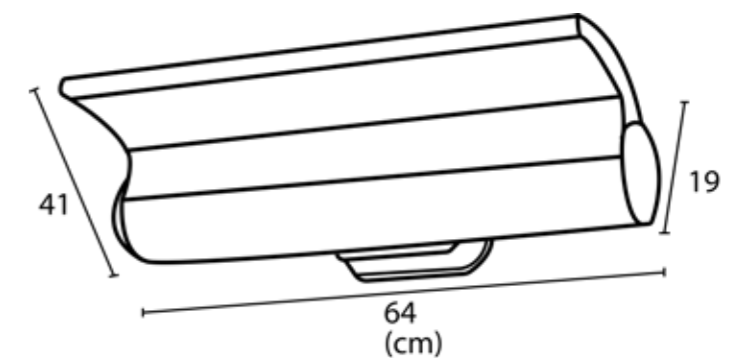

IT

Pratico ed economico riscaldatore con palpebra riflettente da parete con telecomando, ottimo anche come diffusore di calore a parete. Potenza totale 2000 W. Protetto contro i getti d'acqua con IP55.

Il riscaldatore ha incorporata la funzione timer per lo spegnimento, impostabile da 1 a 13 ore.

EN

Practical and economical wall-mounted reflector heater with remote control, also excellent as a wall-mounted heat diffuser. Total power 2000 W. Protected against water jets with IP55.

The heater has a built-in switch-off timer function that can be set from 1 to 13 hours.

FR

Réchauffeur réflecteur mural pratique et économique avec télécommande, également excellent comme diffuseur de chaleur mural. Puissance totale 2000 W. Protégé contre les jets d'eau avec IP55.

L'appareil de chauffage dispose d'une fonction minuterie d'arrêt intégrée qui peut être réglée de 1 à 13 heures.

DE

Praktischer und wirtschaftlicher Wand-Reflektor-Heizstrahler mit Fernbedienung, der sich auch hervorragend als Wand-Wärmeverteiler eignet. Gesamtleistung 2000 W. Geschützt gegen Strahlwasser mit IP65.

Das Heizgerät hat eine eingebaute Abschalt-Timer-Funktion, die von 1 bis 13 Stunden eingestellt werden kann.

ES

Práctico y económico calentador reflector de infrarrojos con control remoto, también excelente como difusor de calor de pared. Potencia total 2000 W. Protegido contra los chorros de agua con IP55.

El calentador tiene una función de temporizador de apagado incorporado que puede ser ajustado de 1 a 13 horas.

CALDO-IRB-NERO-2000

8025431016606



DIMENSIONI 65,8X13,3X8,8 CM
DIMENSIONS 65,8X13,3X8,8 CM

TIPO DI CALORE ONDE MEDIE IR-B
HEAT TYPE MEDIUM WAVE IR-B

COLORE NERO
COLOUR BLACK

PESO 2,9 KG
WEIGHT 2,9 KG

EU directives compliance
LVD 2014/35/UE EMC 2014/30/UE
DERP 2009/125/CE
RoHS 2011/65/EU ((UE) 2015/863)



VETRO BLACK SCHOTT RIDUCE L'EMISSIONE DI LUCE E RADIAZIONI NOCIVE.
BLACK SCHOTT GLASS REDUCES THE EMISSION OF LIGHT AND HARMFUL RADIATION.

LAMPADA RISCALDANTE LOW GLARING
LOW GLARING HEATING LAMP.

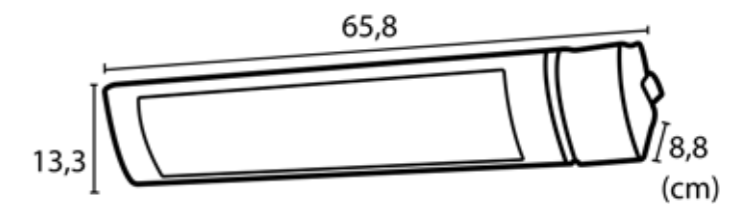

IT

Radiatore a infrarossi ad onde medie IR-B con resistenza in carbonio dalla potenza di 2000W regolabile su 3 livelli. Realizzata con materiali di altissima qualità in alluminio anodizzato e acciaio inox per una durata duratura.

EN

Medium wave infrared radiator IR-B with carbon heating element with 2000W power adjustable on 3 levels. Made from the highest quality materials of anodized aluminum and stainless steel for long lasting durability.

FR

Radiateur infrarouge à ondes moyennes IR-B avec élément chauffant en carbone d'une puissance de 2000W réglable sur 3 niveaux. Le chauffage infrarouge mural est fabriqué en aluminium anodisé de haute qualité et en acier inoxydable pour une longue durée de vie.

DE

Mittelwellen-Infrarotstrahler IR-B mit Kohlen-Heizelement Leistung 2000W einstellbar auf 3 Stufen. Dieser Infrarot-Wandstrahler ist aus hochwertigem eloxiertem Aluminium und Edelstahl für eine lange Lebensdauer gefertigt.

ES

Radiador de infrarrojos de onda media IR-B con elemento calefactor de carbono con 2000W de potencia ajustable en 3 niveles. El calentador infrarrojo de pared está fabricado en aluminio anodizado de alta calidad y acero inoxidable para una larga vida útil.



IT

Riscaldamento elettrico da esterno con potenza 2000W regolabile a 3 livelli 100%, 66% e 33%. Struttura realizzata in alluminio anodizzato e acciaio con griglia di protezione e display a led. Dispone di kit completo di palo.

Dispone di un grado di protezione impermeabile IP65 per ambienti esterni.

EN

Outdoor electric heater with power 2000W adjustable to 3 levels 100%, 66 33%. Structure made of anodized aluminium and steel with protection grid and led display. It comes with a complete pole kit.

it has an IP65 waterproof protection degree for outdoor environments.

FR

Chauffage électrique extérieur avec une puissance de 2000W réglable sur 3 niveaux 100%, 66 33%. Structure en aluminium anodisé et acier avec grille de protection et affichage LED. Livré complet avec kit de poteau.

Possède un degré de protection étanche IP65 pour les environnements extérieurs.

DE

Elektrischer Terrassenstrahler für den Außenbereich mit 2000W Leistung, einstellbar auf 3 Stufen 100%, 66% oder 33%. Struktur aus eloxiertem Aluminium und Stahl mit Schutzgitter und LED-Anzeige. Komplett mit Ständer.

Schutzklasse IP65 mit Schutz gegen Strahlwasser aus beliebiger Richtung.

ES

Calentador eléctrico de exterior con 2000W de potencia ajustable a 3 niveles 100%, 66 y 33%. Estructura de aluminio anodizado y acero con rejilla de protección y pantalla LED. Viene completo con el kit de pie.

Tiene un grado de protección IP65 a prueba de agua para ambientes exteriores.

CALDO-IRA-INOX-PALO

8025431016583

CALDO-IRA-INOX-PALO-WIFI

8025431018839



DIMENSIONI 80X21,5X23 CM
DIMENSIONS 80X21,5X23 CM

COLORE ARGENTO
COLOUR SILVER

TIPO DI CALORE ONDA CORTA IR-A
HEAT TYPE SHORT WAVE IR-A

PESO 22,6 KG
WEIGHT 22,6 KG

EU directives compliance
LVD 2014/35/UE EMC 2014/30/UE
DERP 2009/125/CE
RoHS 2011/65/EU ((UE) 2015/863)



LAMPADA A BASSO ABBAGLIAMENTO E ANTIRIFLESSO
LOW GLARE AND ANTI-REFLECTION LAMP

CONTROL VIA SMARTPHONE
WIFI MODEL ONLY

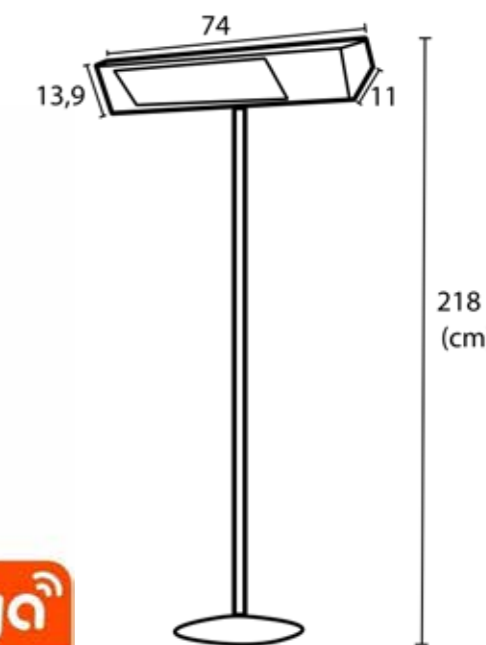



CALDO-VETRO-NERO-PIEDISTALLO

8025431016620

CALDO-VETRO-NERO-PIEDISTALLO-WIFI



8025431018853

DIMENSIONI 218X74,2X11 CM
DIMENSIONS 218X74,2X11 CM

COLORE ARGENTO
COLOUR SILVER

TIPO DI CALORE ONDA CORTA IR-A
HEAT TYPE SHORT WAVE IR-A

PESO 21,2 KG
WEIGHT 21,2 KG

EU directives compliance
LVD 2014/35/UE EMC 2014/30/UE
DERP 2009/125/CE
RoHS 2011/65/EU ((UE) 2015/863)



IT

Radiatore a infrarossi per esterni dalla potenza di 2000W con piedistallo a onda corta IR-A, il nostro prodotto può raggiungere la potenza massima in meno di 8 secondi.

Realizzato con materiale di alta qualità acciaio inox, alluminio anodizzato e vetroceramico, per questo è stato classificato come grado di protezione IP65.

EN

Outdoor infrared heater with 2000W power with IR-A short wave pedestal, our product can reach maximum power in less than 8 seconds.

Our infrared heat is made of high quality material stainless steel, anodized aluminum and glass ceramic, so it is classified as IP65 protection grade.

FR

Réchauffeur infrarouge extérieur d'une puissance de 2000W avec piédestal IR-A à ondes courtes, notre produit peut atteindre la puissance maximale en moins de 8 secondes.

Est fait de matériaux de haute qualité en acier inoxydable, aluminium anodisé et verre céramique, c'est pourquoi il est classé comme protection IP65.

DE

Infrarot-Heizung mit Standfuss für den Außenbereich mit einer Leistung von 2000W. Kurzwellen IR-A Heizung, womit die maximale Leistung in weniger als 8sek. erreicht werden kann.

Ist aus hochwertigem Material Edelstahl, eloxiertem Aluminium und Keramikglas hergestellt und kann dank Schutzklasse IP65 auch in im Garten oder auf der Terrasse aufgestellt werden.

ES

Calentador de infrarrojos para exteriores de 2000W con pedestal IR-A de onda corta. Puede alcanzar la máxima potencia en menos de 8 seg.

Hecho de acero inoxidable, aluminio anodizado y con superficie calentadora patentada en Cristal Negro, por eso está clasificado como grado de protección IP65.

VETRO BLACK SCHOTT RIDUCE L'EMISSIONE DI LUCE E RADIAZIONI NOCIVE.
BLACK SCHOTT GLASS REDUCES THE EMISSION OF LIGHT AND HARMFUL RADIATION.

LAMPADA RISCALDANTE LOW GLARING
LOW GLARING HEATING LAMP.

CONTROLLO TRAMITE SMARTPHONE SOLO MODELLO WIFI
CONTROL VIA SMARTPHONE WIFI MODEL ONLY

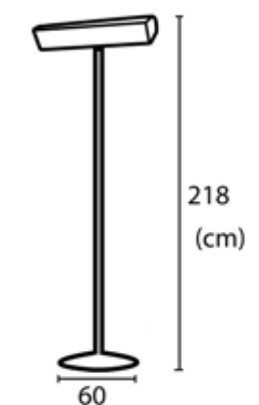
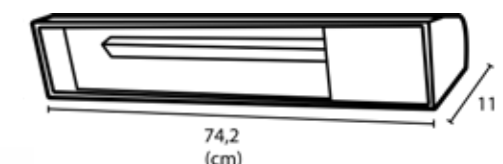



STUFA-INFRAROSSI-TERRA-2000

8025431012288

STUFA-INFRAROSSI-TERRA-4000

8025431016644



DIMENSIONI 218X60X60 CM
DIMENSIONS 218X60X60 CM

TIPO DI CALORE ONDA CORTA IR-A
HEAT TYPE SHORT WAVE IR-A

COLORE GRIGIO
COLOUR GREY

PESO 21,5 KG
WEIGHT 21,5 KG

EU directives compliance
LVD 2014/35/UE EMC 2014/30/UE
DERP 2009/125/CE
RoHS 2011/65/EU ((UE) 2015/863)



IT

Riscaldatore palpebra riflettente da terra su piantana Riscaldatore con palpebra riflettente orientabile da parete con telecomando, ottimo anche come diffusore di calore a parete. Potenza totale 2000 W. Protetto contro i getti d'acqua con IP55. Il cavo elettrico risulta nascosto all'interno dell'asta

LAMPADA RISCALDANTE LOW GLARING
LOW GLARING HEATING LAMP.

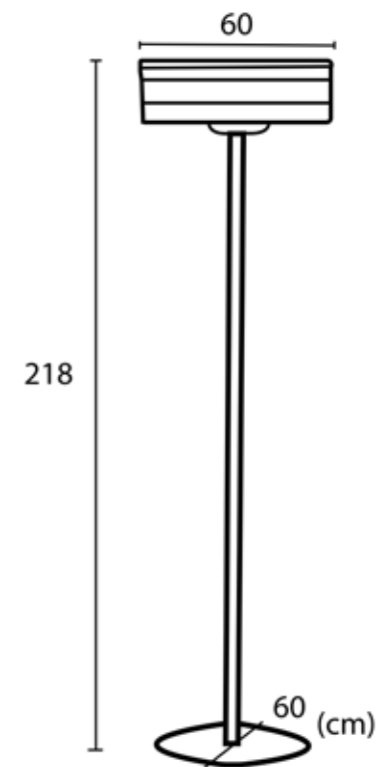

EN

Floor standing reflective eyelid heater Adjustable wall mounted reflective eyelid heater with remote control, also excellent as a wall mounted heat diffuser. Total power 2000 W. Protected against water jets with IP55. The electric cable is hidden inside the pole.

FR

Chauffe-paupières réfléchissant sur pied Chauffe-paupières réfléchissant mural réglable avec télécommande, également excellent comme diffuseur de chaleur mural. Puissance totale 2000 W. Protégé contre les jets d'eau avec IP55. Le câble électrique est dissimulé à l'intérieur du poteau.

DE

Bodenstehender reflektierender Heizstrahler, auch als Außenheizung geeignet. Terrassenheizer mit inklusiver Fernbedienung. Gesamtleistung 2000 W. Geschützt gegen Strahlwasser mit IP65. Das Stromkabel ist im Inneren des Ständers versteckt.

ES

Calentador de infrarrojos con parábola reflectante, instalación de pie o de pared. Calentador de pared ajustable con control remoto, también llega con base para el montaje independiente, garantizando la movilidad y la versatilidad. Potencia 2000 W. Protegido contra los chorros de agua con IP55. El cable eléctrico está oculto dentro del poste.



CALDO-IRB-NERO-TERRA

8025431016613



DIMENSIONI 65,8X218X8,8 CM
DIMENSIONS 65,8X218X8,8 CM

COLORE NERO
COLOUR BLACK

TIPO DI CALORE ONDE MEDIE IR-B
HEAT TYPE MEDIUM WAVE IR-B

PESO 20,4 KG
WEIGHT 20,4 KG

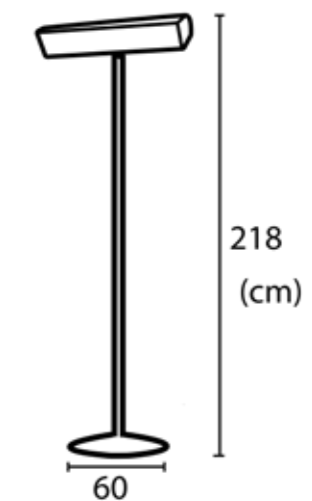
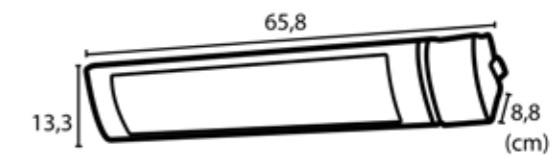

IT

Riscaldatore elettrico a infrarossi completo di piedistallo da 2000W regolabili, l'irraggiamento avviene tramite onde medie IR-B. Realizzata con materiali di altissima qualità in alluminio anodizzato e acciaio inox per una durata duratura.

EN

Electrical infrared heater complete with adjustable 2000W pedestal, radiation is via IR-B medium waves. Made from the highest quality materials of anodized aluminum and stainless steel for long lasting durability.

FR

Chauffeur électrique à infrarouge complet avec socle 2000W réglable, le rayonnement se fait par ondes moyennes IR-B. Fabriqué avec des matériaux de haute qualité en aluminium anodisé et en acier inoxydable pour une longue durée de vie.

DE

Elektrische Infrarotheizung komplett mit Standfuss 2000W einstellbar, Strahlung erfolgt mit IR-B Mittelwellen. Hergestellt aus hochwertigen Materialien wie eloxiertem Aluminium und Edelstahl für eine lange Lebensdauer.

ES

Calentador eléctrico infrarrojo completo con pedestal 2000W ajustable, la radiación es a través de ondas medias IR-B. Fabricado con materiales de la más alta calidad de aluminio anodizado y acero inoxidable para una larga vida útil.

EU directives compliance
 LVD 2014/35/UE EMC 2014/30/UE
 DERP 2009/125/CE
 RoHS 2011/65/EU ((UE) 2015/863)

SUPPORTO-RISCALDATORE

8025431016651



PESO 18 KG
WEIGHT 18 KG



DIMENSIONI 218X60X60 CM
DIMENSIONS 218X60X60 CM

COLORE ARGENTO
COLOUR SILVER

COMPATIBILE CON DIVERSI MODELLI
COMPATIBLE WITH MULTIPLE MODELS

218

60 (cm)

IT

Palo In Acciaio 304 Antiribaltamento Supporto Da Pavimento Per Lampade a Raggi Infrarossi Adatto Per Il Montaggio Di 2 Stufe Infrarossi a Palpebra Oppure 1 Solo Caldo-vetro Oppure Caldo-ira Oppure Caldo Irb

EN

Floor Stand For Infrared Lamps Suitable For Mounting 2 Infrared Eyelid Heaters Or 1 Hot-glass Or Hot-ira Or Hot-irb Only.

FR

Support De Sol Pour Lampes Infrarouges Permettant De Monter 2 Radiateurs Réfléchissants Sined Ou 1 Seul Caldo-vetro Ou Caldo-ira Ou Caldo-irb.

DE

Bodenständer Für Infrarotstrahler Geeignet Für Die Montage Von 2 Infrarot-reflektorstrahlern Sined Oder Nur 1 Caldo-vetro Oder Caldo-ira Oder Caldo-irb.

ES

Soporte De Suelo Para Lámparas De Infrarrojos Adecuado Para Montar 2 Calentadores De Párpados Infrarrojos o 1 Hot-glass o Hot-ira o Hot-irb Solamente.



IT

Doppio riscaldatore riflettente da soffitto con palpebra da 2000W l'uno da un totale di 4000W realizzate in acciaio inox e alluminio anodizzato di altissima qualità.

Riscaldatore riflettente da soffitto a onda corta IR-A, il dispositivo arriva alla sua potenza massima in meno 8 secondi.

EN

Double reflective ceiling heater with 2000W each with a total of 4000W made of stainless steel and anodized aluminum of the highest quality.

Short wave IR-A reflective ceiling heater, the device reaches its maximum power in less than 8 seconds.

FR

Double radiateur de plafond réfléchissant de 2000W chacun avec un total de 4000W fabriqué en acier inoxydable de la plus haute qualité et en aluminium anodisé.

L'IR à ondes courtes - un chauffage de plafond réfléchissant, l'appareil atteint sa puissance maximale en moins de 8 secondes.

DE

Doppelte reflektierende Deckenheizung mit je 2000W Gesamtleistung 4000W aus hochwertigem Edelstahl und eloxiertem Aluminium.

Der IR-A-Deckenstrahler erreicht seine maximale Leistung in weniger als 8 Sekunden.

ES

Calentador de techo doble de 2000W cada uno con un total de 4000W fabricado en acero inoxidable y aluminio anodizado de la más alta calidad. Diseño especial con parábola reflectante para maximizar la eficiencia de la calefacción.

Calentador de techo IR-A de onda corta, el dispositivo alcanza su máxima potencia en menos de 8 segundos

STUFA-INFRAROSSI-SOFFITTO-4000

8025431015562



DIMENSIONI 40X60X74 CM
DIMENSIONS 40X60X74 CM

COLORE GRIGIO
COLOUR GREY

EU directives compliance
LVD 2014/35/UE EMC 2014/30/UE
DERP 2009/125/CE
RoHS 2011/65/EU ((UE) 2015/863)

TIPO DI CALORE ONDA CORTA IR-A
HEAT TYPE SHORT WAVE IR-A

PESO 10 KG
WEIGHT 10 KG



LAMPADA RISCALDANTE LOW GLARING
LOW GLARING HEATING LAMP.

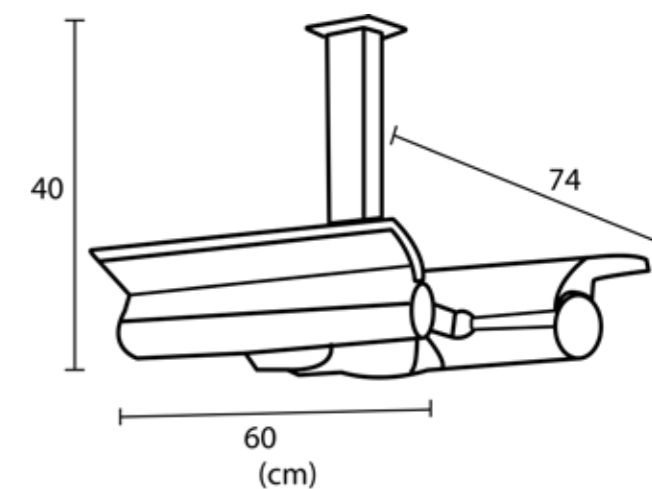



STAFFE-GEMELLE-RISCALDATORE

8025431012325



DIMENSIONI 17X13X39,5 CM
DIMENSIONS 17X13X39,5 CM

PESO 1,3 KG
WEIGHT 1,3 KG

COLORE ARGENTO
COLOUR SILVER



IT

Staffe Per Fissaggio a Soffitto Di Una Coppia Di Riscaldatori Sined a Palpebra Riflettente i Riscaldatori Non Sono Compresi, Ma Devono Essere Acquistati Separatamente

EN

Brackets For Ceiling Mounting Of a Pair Of Wall Reflecting Eyelid Heaters. Heaters Are Not Included, But Must Be Purchased Separately.

FR

Supports Pour Le Montage Au Plafond De 2 Radiateurs Réfléchissants Sined. Les Chauffages Ne Sont Pas Inclus, Mais Doivent Être Achetés Séparément

DE

Halterungen Für Die Deckenmontage Von 2 Sined Reflektorstrahlern. Heizgeräte Sind Nicht Inbegriffen, Müssen Aber Separat Erworben Werden.

ES

Soportes Para El Montaje En El Techo De Un Par De Calefactor De Párpados Reflectores De Pared. Los Calefactor No Están Incluidos, Pero Deben Comprarse Por Separado.

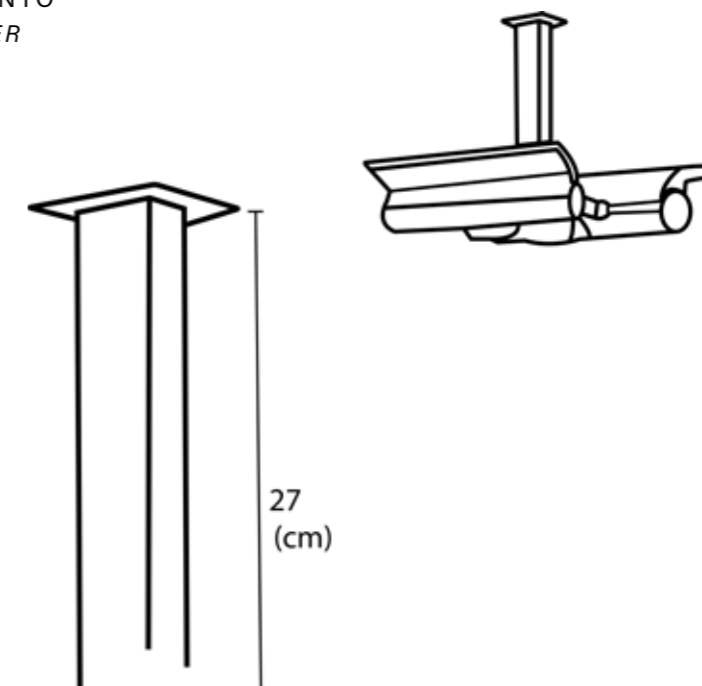



CALORE-BIANCO-1500

8025431012240

CALORE-BIANCO-1800

8025431012257

CALORE-BIANCO-2400

8025431012264

CALORE-BIANCO-3200

8025431012271



EMETTE SOLO LA PARTE MIGLIORE DEL CALORE DEL SOLE, CHE È BENEFICO PER LA SALUTE.
EMITS ONLY THE BEST PART OF THE SUN'S HEAT, WHICH IS BENEFICIAL TO HEALTH.

DIMENSIONI 104,5-191,5X17,7X6 CM
DIMENSIONS 104,5-191,5X17,7X6 CM

TIPO DI CALORE ONDE LUNGHE A7 IR-C
HEAT TYPE LONG WAVE A7 IR-C

COLORE BIANCO
COLOUR WHITE

PESO 5,4/6,1/7,5/9,5 KG
WEIGHT 5,4/6,1/7,5/9,5 KG

EU directives compliance
 LVD 2014/35/UE EMC 2014/30/UE
 DERP 2009/125/CE
 RoHS 2011/65/EU ((UE) 2015/863)



IT

Lo speciale elemento riscaldante in alluminio trasforma il 99% dell'energia elettrica in calore. Il risparmio energetico è dato dal fatto che questi riscaldatori infrarossi riscaldano direttamente le persone, non tutto l'ambiente come i riscaldatori tradizionali. Radiatore a infrarossi per esterni serie A7 IR-C, infrarosso lontano con nessuna emissione di luce.

EN

Outdoor infrared heater series A7 IR-C, far infrared with no light emission. Extruded aluminum alloy heating element with ceramic infrared paint. Stainless steel bracket included, suitable for ceiling and wall mounting. Water proof: IP65, suitable for dust and rain outdoors. Best performance in very sheltered and windless outdoor or indoor areas, such as winter gardens.

FR

Chauffage infrarouge extérieur série A7 IR-C, infrarouge lointain sans émission de lumière. En alliage d'aluminium extrudé avec revêtement céramique infrarouge. Adapté au montage au plafond et au mur. Etanche à l'eau : IP65, convient à la poussière et à la pluie à l'extérieur. Meilleures performances dans les zones extérieures ou intérieures très abritées et sans vent, comme les jardins d'hiver.

DE

Außen-Infrarotstrahler IR-C Langwellen Infrarot-Heizung ohne Lichtemission. Heizelement aus Aluminiumlegierung, Gehäuse mit Keramikbeschichtung Farbe Weiss. Inklusive Edelstahlhalterung, geeignet für Decken- und Wandmontage. Wasserdicht: IP65, geeignet für Staub und Regen im Freien. Beste Leistung in sehr geschützten und windstillen Außen- oder Innenbereichen.

ES

Calentador de infrarrojo exterior serie A7 IR-C, de onda larga sin emisión de luz. De aleación de aluminio con pintura cerámica. Se incluye soporte inox. para montaje en techo o pared. A prueba de agua: IP65, apto para polvo y la lluvia en exterior. El mejor rendimiento es áreas exteriores o interiores protegidas de viento, como invernaderos.

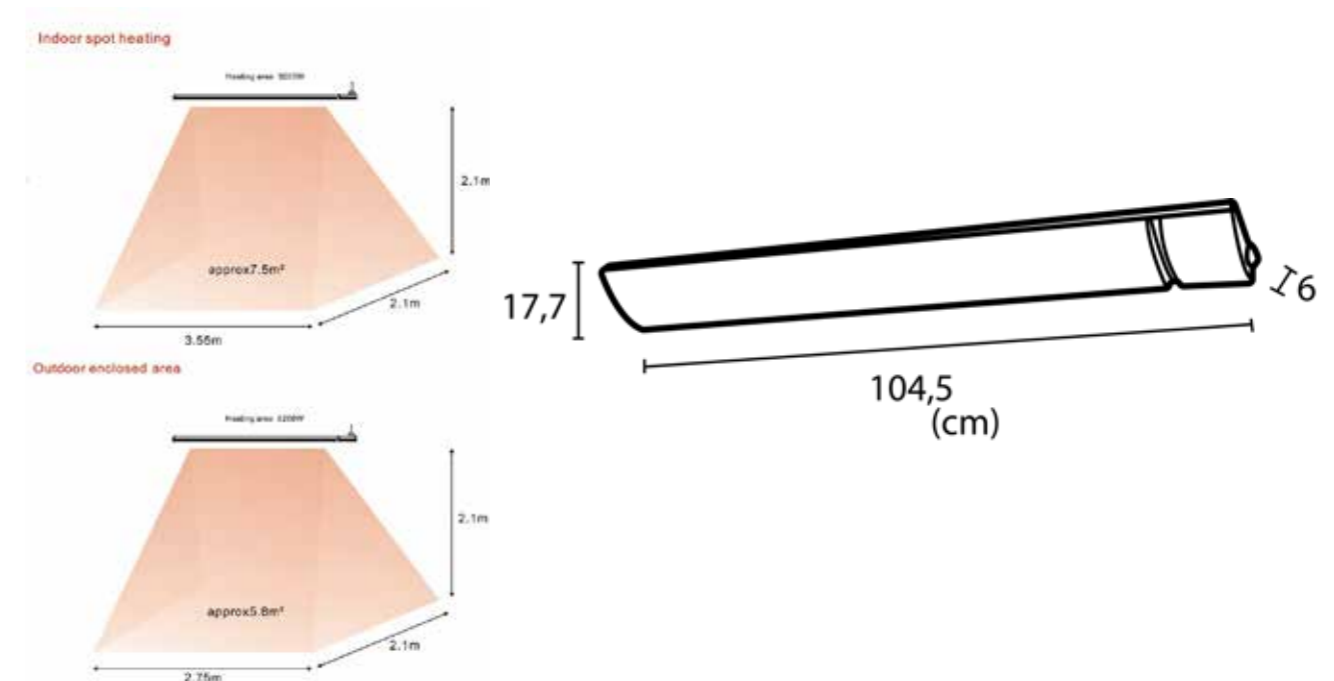



IT

Lo speciale elemento riscaldante in alluminio trasforma il 99% dell'energia elettrica in calore. Il risparmio energetico è dato dal fatto che questi riscaldatori infrarossi riscaldano direttamente le persone, non tutto l'ambiente come i riscaldatori tradizionali. Radiatore a infrarossi per esterni serie A7 IR-C, infrarosso lontano con nessuna emissione di luce.

EN

Outdoor infrared heater series A7 IR-C, far infrared with no light emission. Extruded aluminum alloy heating element with ceramic infrared paint. Stainless steel bracket included, suitable for ceiling and wall mounting. Water proof: IP65, suitable for dust and rain outdoors. Best performance in very sheltered and windless outdoor or indoor areas, such as winter gardens.

FR

Chauffage infrarouge extérieur série A7 IR-C, infrarouge lointain sans émission de lumière. En alliage d'aluminium extrudé avec revêtement céramique infrarouge. Adapté au montage au plafond et au mur. Etanche à l'eau : IP65, convient à la poussière et à la pluie à l'extérieur. Meilleures performances dans les zones extérieures ou intérieures très abritées et sans vent, comme les jardins d'hiver.

DE

Außen-Infrarotstrahler IR-C Langwellen Infrarot-Heizung ohne Lichtemission. Heizelement aus Aluminiumlegierung, Gehäuse mit Keramikbeschichtung Farbe Weiss. Inklusive Edelstahlhalterung, geeignet für Decken- und Wandmontage. Wasserdicht: IP65, geeignet für Staub und Regen im Freien. Beste Leistung in sehr geschützten und windstillen Außen- oder Innenbereichen.

ES

Calentador de infrarrojo exterior serie A7 IR-C, de onda larga sin emisión de luz. De aleación de aluminio con pintura cerámica. Se incluye soporte inox. para montaje en techo o pared. A prueba de agua: IP65, apto para polvo y la lluvia en exterior. El mejor rendimiento es áreas exteriores o interiores protegidas de viento, como invernaderos.

CALORE-NERO-1500

8025431016521

CALORE-NERO-1800

8025431016538

CALORE-NERO-2400

8025431016545

CALORE-NERO-3200

8025431016552

DIMENSIONI 104,5-191,5X17,7X6 CM
DIMENSIONS 104,5-191,5X17,7X6 CM

COLORE NERO
COLOUR BLACK

EU directives compliance
 LVD 2014/35/UE EMC 2014/30/UE
 DERP 2009/125/CE
 RoHS 2011/65/EU ((UE) 2015/863)



TIPO DI CALORE ONDE LUNGHE A7 IR-C
HEAT TYPE LONG WAVE A7 IR-C

PESO 5,4/6,1/7,5/9,5 KG
WEIGHT 5,4/6,1/7,5/9,5 KG



EMETTE SOLO LA PARTE MIGLIORE DEL CALORE DEL SOLE, CHE È BENEFICO PER LA SALUTE.
EMITS ONLY THE BEST PART OF THE SUN'S HEAT, WHICH IS BENEFICIAL TO HEALTH.

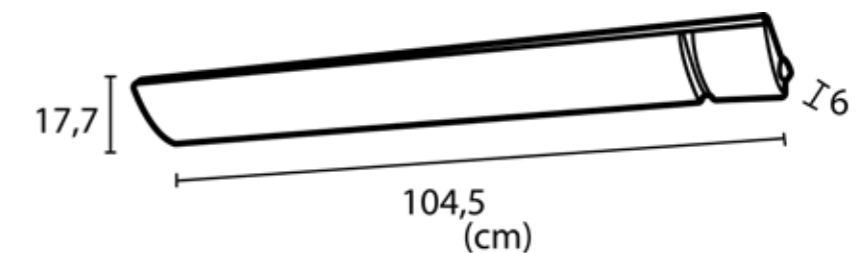



t[®] CALORE-NERO-1500-WIFI

8025431018907

t[®] CALORE-NERO-1800-WIFI

8025431018914

t[®] CALORE-NERO-2400-WIFI

8025431018921

t[®] CALORE-NERO-3200-WIFI

8025431018938



DIMENSIONI 104,5-191,5X17,7X6 CM
DIMENSIONS 104,5-191,5X17,7X6 CM

TIPO DI CALORE ONDE LUNGHE A7 IR-C
HEAT TYPE LONG WAVE A7 IR-C

COLORE NERO
COLOUR BLACK

PESO 5,4/6,1/7,5/9,5 KG
WEIGHT 5,4/6,1/7,5/9,5 KG

EU directives compliance
 LVD 2014/35/UE EMC 2014/30/UE
 DERP 2009/125/CE
 RoHS 2011/65/EU ((UE) 2015/863)



IT

Lo speciale elemento riscaldante in alluminio trasforma il 99% dell'energia elettrica in calore. Il risparmio energetico è dato dal fatto che questi riscaldatori infrarossi riscaldano direttamente le persone, non tutto l'ambiente come i riscaldatori tradizionali. Radiatore a infrarossi per esterni serie A7 IR-C, infrarosso lontano con nessuna emissione di luce.

EMETTE SOLO LA PARTE MIGLIORE DEL CALORE DEL SOLE, CHE È BENEFICO PER LA SALUTE.
EMITS ONLY THE BEST PART OF THE SUN'S HEAT, WHICH IS BENEFICIAL TO HEALTH.

CONTROLLO TRAMITE SMARTPHONE SOLO MODELLO WIFI
CONTROL VIA SMARTPHONE WIFI MODEL ONLY

EN

Outdoor infrared heater series A7 IR-C, far infrared with no light emission. Extruded aluminum alloy heating element with ceramic infrared paint. Stainless steel bracket included, suitable for ceiling and wall mounting. Water proof: IP65, suitable for dust and rain outdoors. Best performance in very sheltered and windless outdoor or indoor areas, such as winter gardens.

FR

Chauffage infrarouge extérieur série A7 IR-C, infrarouge lointain sans émission de lumière. En alliage d'aluminium extrudé avec revêtement céramique infrarouge. Adapté au montage au plafond et au mur. Etanche à l'eau : IP65, convient à la poussière et à la pluie à l'extérieur. Meilleures performances dans les zones extérieures ou intérieures très abritées et sans vent, comme les jardins d'hiver.

DE

Außen-Infrarotstrahler IR-C Langwellen Infrarot-Heizung ohne Lichtemission. Heizelement aus Aluminiumlegierung, Gehäuse mit Keramikbeschichtung Farbe Weiss. Inklusive Edelstahlhalterung, geeignet für Decken- und Wandmontage. Wasserdicht: IP65, geeignet für Staub und Regen im Freien. Beste Leistung in sehr geschützten und windstillen Außen- oder Innenbereichen.

ES

Calentador de infrarrojo exterior serie A7 IR-C, de onda larga sin emisión de luz. De aleación de aluminio con pintura cerámica. Se incluye soporte inox para montaje en techo o pared. A prueba de agua: IP65, apto para polvo y la lluvia en exterior. El mejor rendimiento es áreas exteriores o interiores protegidas de viento, como invernaderos.

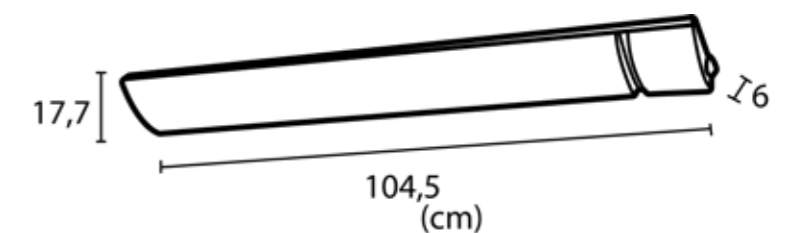

MOBILI SU MISURA PER CAMINETTI

CUSTOM-MADE FURNITURE FOR FIREPLACES

I mobili per caminetti Sined sono realizzati da ebanisti artigiani con materiali di qualità e un grande design di stile Italiano. Ogni modello viene realizzato su ordinazione, ed è praticamente un pezzo unico, con una sua anima e stile.

Sined fireplace furniture is made by artisan cabinet-makers with quality materials and great Italian-style design. Each model is made to order, and is practically a unique piece with its own soul and style.



MOBILE-CAMINO-MEDA



COLORE ROVERE
COLOUR OAK

MOBILI PERSONALIZZATI SU MISURA
CUSTOMISED FURNITURE MADE TO MEASURE

TEMPI DI CONSEGNA SU RICHIESTA
DELIVERY TIME ON REQUEST

MADE IN EUROPE



IT

Mobile TV laccato corallo con camino elettrico e piano in rovere nodato. Con due ante a battente e ripiani interni. Si tratta di un mobile con camino elettrico integrato di qualità garantita. Il calore è diretto verso la parte anteriore ed è controllato da un telecomando.

EN

Coral lacquered TV cabinet with electric fireplace and a top in knotty oak. With two hinged doors and interior shelves. This is a piece of furniture with an integrated electric fireplace with guaranteed quality. The heat is directed to the front and is controlled by a remote control.

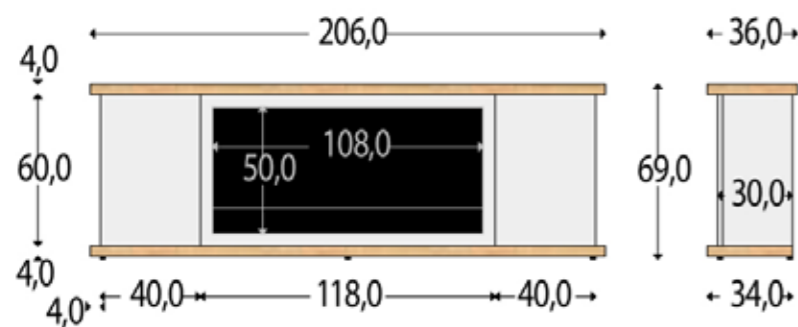

MISURE CON MODELLO CAMINETTO-ISPICA-108 DI 108CM. DISPONIBILE IN ALTRE MISURE.
MEASUREMENTS WITH MODEL CAMINETTO-ISPICA-108 OF 108CM. AVAILABLE IN OTHER SIZES.

MOBILE-CAMINO-DESIO



COLORE BIANCO
COLOUR WHITE

MOBILI PERSONALIZZATI SU MISURA
CUSTOMISED FURNITURE MADE TO MEASURE

TEMPI DI CONSEGNA SU RICHIESTA
DELIVERY TIME ON REQUEST

MADE IN EUROPE



IT

Si tratta di un mobile con camino elettrico, laccato in grigio perla, con piano rifinito in rovere nodoso e dotato di due ante e due cassetti. Realizzato con materiali di qualità. Le lacche non ingialliscono nel tempo e il legno ha strati di vernice che conferiscono resistenza al mobile.

EN

This is a piece of furniture with an electric fireplace, it is lacquered in pearl grey, has a top finished in knotty oak and has two doors and two drawers. Made with quality materials. The lacquers do not yellow over time and the wood has layers of varnish that give the piece of furniture resistance.

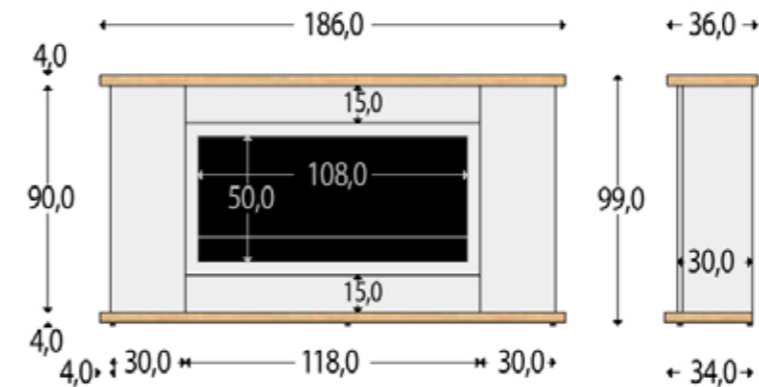

MISURE CON MODELLO CAMINETTO-ISPICA-108 DI 108CM. DISPONIBILE IN ALTRE MISURE.
MEASUREMENTS WITH MODEL CAMINETTO-ISPICA-108 OF 108CM. AVAILABLE IN OTHER SIZES.

MOBILE-CAMINO-CARATE



COLORE NERO
COLOUR BLACK

MOBILI PERSONALIZZATI SU MISURA
CUSTOMISED FURNITURE MADE TO MEASURE

TEMPI DI CONSEGNA SU RICHIESTA
DELIVERY TIME ON REQUEST

MADE IN EUROPE



IT

Si tratta di un mobile con camino elettrico, laccato in colore grafite e con piano e base in laminato Tacande. Realizzato con materiali di qualità, tutti di origine spagnola.

EN

It is a piece of furniture with electric fireplace, the furniture is lacquered in graphite colour and has a top and a base in Tacande laminate finishes. Manufactured with quality materials all of Spanish origin.

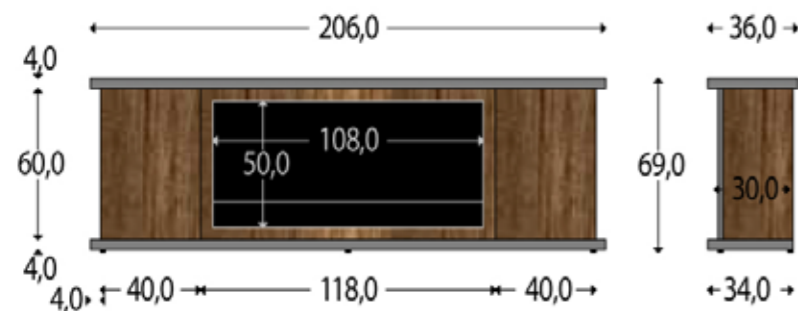

MISURE CON MODELLO CAMINETTO-ISPICA-108 DI 108CM. DISPONIBILE IN ALTRE MISURE.
MEASUREMENTS WITH MODEL CAMINETTO-ISPICA-108 OF 108CM. AVAILABLE IN OTHER SIZES.

MOBILE-CAMINO-AROSIO



COLORE NERO
COLOUR BLACK

MOBILI PERSONALIZZATI SU MISURA
CUSTOMISED FURNITURE MADE TO MEASURE

TEMPI DI CONSEGNA SU RICHIESTA
DELIVERY TIME ON REQUEST

MADE IN EUROPE



IT

Si tratta di un mobile con camino elettrico, laccato in nero e con piano e base rifiniti in rovere nodoso. Realizzato con materiali di qualità. Le lacche non ingialliscono nel tempo e il legno ha strati di vernice che conferiscono resistenza al mobile.

EN

This is a piece of furniture with an electric fireplace, the piece of furniture is lacquered in black and has a top and base finished in knotty oak. Made with quality materials. The lacquers do not yellow over time and the wood has layers of varnish that give the piece of furniture resistance.

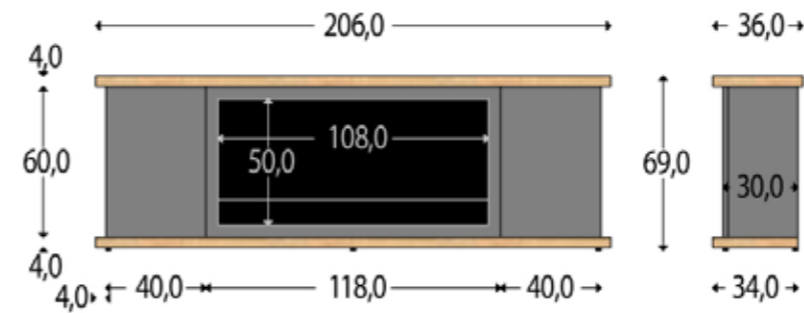

MISURE CON MODELLO CAMINETTO-ISPICA-108 DI 108CM. DISPONIBILE IN ALTRE MISURE.
MEASUREMENTS WITH MODEL CAMINETTO-ISPICA-108 OF 108CM. AVAILABLE IN OTHER SIZES.

MOBILE-CAMINO-LISSONE



TEMPI DI CONSEGNA SU RICHIESTA
DELIVERY TIME ON REQUEST

MOBILI PERSONALIZZATI SU MISURA
CUSTOMISED FURNITURE MADE TO MEASURE

HANDMADE IN ITALY



IT

Il modello Lissone di Sined è realizzato con materiali di qualità e un grande design italiano. Ogni modello è realizzato su ordinazione ed è praticamente un pezzo unico. Lissone ha due ante e diversi cassetti.

EN

The Lissone model by Sined is made with quality materials and a great Italian design. Each model is made to order and is practically a unique piece. Lissone has two doors and several drawers.

***FATTO SU MISURA.CUSTOM MADE.**

MOBILE-CAMINO-SEREGNO



TEMPI DI CONSEGNA SU RICHIESTA
DELIVERY TIME ON REQUEST

MOBILI PERSONALIZZATI SU MISURA
CUSTOMISED FURNITURE MADE TO MEASURE

HANDMADE IN ITALY



IT

Il modello Seregno di Sined è realizzato con materiali di qualità e un grande design italiano. Ogni modello è realizzato su ordinazione ed è praticamente un pezzo unico. Lissone ha diversi cassetti.

EN

The Seregno model by Sined is made with quality materials and a great Italian design. Each model is made to order and is practically a unique piece. Lissone has several drawers.

***FATTO SU MISURA.CUSTOM MADE.**





Italia: M.P.C. Srl
Via Tortona 21
20144 Milano, Italia

Logística: Gruppo Sinergia
Via Tavole di Casalbergo 7
37063 Isola della Scala (VR)

España: Sined V.O. S.L.U.
Avenida Diagonal, 413 5º 2ª
08008 Barcelona España

Logística: Stockabee
Calle Tapiceros 5 Nave K
28830 San Fernando de Henares
Madrid

TELEFONO IT +39 022 1117815
MOBILE IT +39 335 7600875
MOBILE EN/FR +39 3425447140
TELÉFONO ES +34 664 66 64 26
TELÉFONO ES +34 664 66 64 28

INFO@SINEDITALIA.COM

SINEDITALIA.COM
SINEDITALIA.IT
SINED.ES



Si ringrazia l'Hotel Relais Torre Marabino (Ispica RG Italia / www.torremarabino.com) per averci concesso il loro spazio per il servizio fotografico.